



User Manual

Model STVI

Smart Touch View Interface

Model SMRT1

Single Phase Relay Test System

Model SMRT33/36

Three Phase Relay Test System

Model SMRT410

Multi Phase Relay Test System

Model MPRT8445

Multi Phase Relay Test System

Model MPRT2145

Single Phase Relay Test System

Revision History

<u>Revision</u>	<u>ECN #</u>	<u>Date</u>
1	Initial Release	6/7/2011
2	31676	8/4/2011
3	31736	12/7/2011
4	31882	9/15/2012
5	32089	3/21/2013
6	32124	4/24/2013
7	32289	3/24/2014

IMPORTANT

This manual, as well as the hardware and software described in it, is furnished under license and may be used or copied only in accordance with the terms of such license. The content of this manual is furnished for informational use only, is subject to change without notice. Megger assumes no responsibility or liability for any errors or inaccuracies that may appear in this manual.

The information and data in this User Manual are proprietary. The equipment described herein may be protected by U.S. patents. Megger specifically reserves all rights to such proprietary information as well as rights under any patent, none of which is waived by the submission of this user manual.

Except as permitted by such license, no part of this publication may be reproduced, stored in a retrieval system, or transmitted, in any form or by any means, electronic, mechanical, recording, or otherwise, without the prior written permission of Megger.

Megger, the Megger logo are trademarks of Megger. All other trademarks are the property of their respective owners.

Notice to U.S. government end users. The hardware, software and documentation are "commercial items", as that term is defined at 48 C.F.R. §2.101, consisting of "commercial computer software" and "commercial computer software documentation," as such terms are used in 48 C.F.R. §12.212 or 48 C.F.R. §227.7202, as applicable. Consistent with 48 C.F.R. §12.212 or 48 C.F.R. §§227.7202-1 through 227.7202-4, as applicable, the commercial computer software and commercial computer software documentation are being licensed to U.S. government end users (1) only as commercial items and (2) with only those rights as are granted to all other end users pursuant to the terms and conditions set forth in the Megger standard commercial agreement for this software and hardware. Unpublished rights reserved under the copyright laws of the United States. The recipient, if a Government agency, acknowledges that this manual and the equipment described were procured with "Limited Rights" to technical data as described in ASPR 9-203 (b).

The STVI includes an RTOS-resident computer program. This program belongs to Megger and contains trade secret ideas and information of Megger.



Written and designed at Megger, 4271 Bronze Way, Dallas, Texas 75237.

Printed in the USA.
© 2014 Megger, all rights reserved.

SAFETY PRECAUTIONS

WARNING: VOLTAGES GENERATED BY THIS INSTRUMENT CAN BE HAZARDOUS

This instrument has been designed for operator safety; however, no design can completely protect against incorrect use. Electrical circuits are dangerous and can be lethal when lack of caution and poor safety practices are used. There are several standard safety precautions that should be taken by the operator. Where applicable, IEC safety markings have been placed on the instrument to notify the operator to refer to the user manual for instructions on correct use or safety related topics. Refer to the following table of symbols and definitions.

Symbol	Description
===	Direct Current
~	Alternating Current
⎓	Both direct and alternating current
⏏	Earth (ground) Terminal. There is a common chassis ground terminal located on the front panel (see Front panel under Description of Controls).
⏏	Protective Conductor Terminal
⏏	Frame or Chassis Terminal
	On (Supply)
○	Off (Supply)
	Caution, risk of electric shock
	Caution (refer to accompanying documents)

 **WARNING:** Under no circumstances should the operator or technician attempt to open or service any Megger instrument while connected to a power source. Lethal voltages are present and may cause serious injury or death!

SAFETY PRECAUTIONS (Continued)

The following are some specific safety related items associated with the SMRT test system.

Read and understand all safety precautions and operation instructions before attempting to use this unit.

The purpose of this equipment is limited to use as described in this instruction manual. Should a situation arise that is not covered in the general or specific safety precaution please contact Megger regional representative or Megger, Dallas Texas.

Safety is the responsibility of the user. Misuse of this equipment can be extremely dangerous.

Always start with the power OFF, before connecting the power cord. Make sure outputs are off before attempting to make test connections.

Never connect the test set to energized equipment.

Always use properly insulated test leads. The optional test leads are rated for the continuous output ratings of the test system, and should be properly used and cared for. DO NOT use cracked or broken test leads.

Always turn the test system off before disconnecting the power cord.

DO NOT attempt to use the unit without a safety ground connected.

DO NOT attempt to use the unit if the power cord ground prong is broken or missing.

DO NOT use the test set in an explosive atmosphere.

The instrument must only be used by suitably trained and competent persons.

Observe all safety warnings marked on the equipment.

For safety related or other important topics, like the statement below, will be notated with the adjoined symbol. Read the topic carefully as it may relate either to the safe operation of the test system or the safety of the operator.



Under no circumstances should the operator put their hand or tools inside the test system chassis area with the test system connected to a power source. Lethal voltages are present and may cause serious injury or death!

Table of Contents

Section	Page
Model STVI	1
Smart Touch View Interface	1
Model SMRT1	1
Single Phase Relay Test System	1
Model SMRT33/36	1
Three Phase Relay Test System	1
Model SMRT410	1
Multi Phase Relay Test System	1
Model MPRT8445	1
Multi Phase Relay Test System	1
Model MPRT2145	1
Single Phase Relay Test System	1
Revision History	2
Safety Precautions	4
1.0 STVI Introduction	15
1.1 Smart Touch View Interface	15
1.2 Terminology	16
1.2.1 Acronyms	16
1.2.2 Glossary of Terms	16
1.2.2.1 Pickup (Tap)	17
1.2.2.2 TDM (Time Dial Multiple)	17
1.2.2.3 Inst. (Instantaneous Tap)	17
1.2.2.4 Reset Seconds	17
1.2.2.5 Time Delay	17
1.2.2.6 Test Multiple	17
1.2.2.7 Reach or Diameter	18
1.2.2.8 Angle (Torque)	18
1.2.2.9 Expected Trip Time	18
1.2.2.10 Winding (1,2,3,4) Tap	18
1.2.2.11 Percent (%) Slope	18
1.2.2.12 Percent (%) Harmonic	18
1.2.2.13 Prefault Seconds	18
1.3 Power Over Ethernet Input Power	18
1.3.1. PoE Power Supply-Input Power Cord	19
2.0 SETUP	20
2.1 Unpack System	20
2.2 Communication Ports	20
2.2.1 Ethernet Port	20
2.2.2 USB 2.0 Interface	20
2.3 Smart Touch View Interface	22
2.3.1 Configuration	23
2.3.1.1 Operation Modes	24
2.3.1.2 Battery Simulator	24
2.3.1.2.1 Last VIGEN is Battery	24
2.3.1.3 Phase Angles	24
2.3.1.4 ? Help Button	25
2.3.1.5 Default Settings Options	25
2.3.1.5.1 Save as Default	25
2.3.1.5.2 Restore Default	25
2.3.1.5.3 Restore Factory	25
2.3.1.6 Display Versions (Information Screen)	25

2.3.1.7	Update Firmware	25
2.3.1.8	Auto Frequency	26
2.3.1.9	Fault (Phase) Labels	26
2.3.1.10	Language.....	26
2.3.1.11	Deviation Alarm	26
2.3.1.12	Color Options.....	26
2.3.1.13	Change State Immediately / Change on Zero Cross	26
2.3.1.14	Symmetrical Components	26
2.3.1.15	High Burden.....	26
2.3.1.16	Voltage Character.....	26
2.3.1.17	Date and Time	27
2.3.1.18	Logging.....	27
2.3.1.19	Adjust Screen Brightness	27
2.3.1.20	Ethernet (DHCP) IP Address.....	27
2.3.1.21	Advanced - Convertible V/I Selection for Multi-Phase Current Output	28
2.3.1.22	Screen Exit	28
2.4	STVI Setting Amplitudes, Phase Angle or Frequency	28
2.4.1	Numeric Keypad Entry	28
2.4.2	Include Channel in Ramping.....	29
2.4.3	Control Knob	30
2.4.4	Setting Default Voltage Outputs.....	30
2.4.5	Setting Default Current Outputs	30
2.4.4	Virtual Alphanumeric Keypad.....	30
2.5	STVI File Management	30
3.0	STVI – Basic Operating Descriptions	32
3.1	STVI / PC Manual Test Screen	32
3.1.1	PC or STVI to SMRT connection button	32
3.1.2	The Configuration button.....	33
3.1.3	Battery Simulator button.....	33
3.1.4	Add To Report button.....	33
3.1.5	Nameplate button.....	33
3.1.6	File Folder button	33
3.1.7	Test List button.....	33
3.1.7.1	Ramp button	33
3.1.7.2	Timing Test button	34
3.1.7.3	Sequencing 1,2,3..9 button	34
3.1.7.4	Impedance button.....	34
3.1.7.5	Differential button	34
3.1.7.6	Transducer button	34
3.1.8	Meter Mode button	34
3.1.9	System Reset button	34
3.1.10	Help button	34
3.1.11	Phase Vector Screen.....	35
3.1.12	Binary Input Dialog Box	35
3.1.12.1	Binary More button	36
3.1.12.1.1	Simple Mode button	36
3.1.12.1.2	Show All Inputs button	36
3.1.12.1.3	Show All Outputs button	36
3.1.12.1.4	Advanced button	36
3.1.12.1.4.1	Waveform selection button.....	36
3.1.13	Prefault / Fault buttons	36
3.1.14	Maximum Test Time/Prefault Time/Post Fault Time Settings button	36
3.1.15	Play button.....	37
3.1.16	All ON/All OFF button	37
3.1.17	Manual Ramp Options button.....	37
3.1.16	Channel ON/OFF selector button.....	37

3.1.19	Channel Amplitude, Phase Angle and Frequency buttons.....	37
3.2	Setting Phase Angle Relationships	38
3.3	Current Sources	39
3.3.1	Parallel Operation	39
3.3.1.1	Manual Test Screen - Single Phase Up To180 Ampere	40
3.3.2	Currents in Series Operation	42
3.4	Voltage Sources	43
3.4.1	Outputs Summed Together.....	43
3.4.2	3Ø, 3-Wire, Open-Delta and T-Connection	44
3.4.2.1	Balanced Open Delta	44
3.4.2.1.1	Unbalanced Open Delta	46
3.4.2.2	T-Connection	47
3.4.3	3Ø, 4-Wire, Y-Connection	47
3.5	Testing Relays with the STVI Manual Test Screen	49
3.5.1	Simple Manual Pickup or Dropout Test	49
3.5.2	Simple Manual Timing Test.....	50
3.5.3	Using Auto Ramp/Pulse Ramp/Pulse Ramp Binary Search	52
3.5.3.1	Step Ramp Example.....	52
3.5.3.2	Pulse Ramp Example	52
3.5.3.3	Pulse Ramp Binary Search Example	53
3.5.4	Using Ramp Wizard	53
3.5.4.1	EM (Electromechanical) Current Pickup	54
3.5.4.1	Instantaneous Pickup	55
3.5.4.1	Current Target & Seal In.....	56
3.5.5	Ramping Battery Simulator Output	56
3.5.6	Timing Test	57
3.5.6.1	Timing Test Setup	57
3.5.6.2	Relay Manufacturer and Curve Selection.....	59
3.5.7	Timing Test – Overcurrent Relays	61
3.5.8	Timing Test - Voltage Relays	62
3.5.9	State Sequence Timing Test – Multi-Shot Reclose Relays	63
3.6	Testing Impedance Relays with the STVI Click On Fault	69
3.6.1	Common Settings	69
3.6.1.1	Tolerance Settings.....	69
3.6.1.2	Zone Trip Time Settings	69
3.6.1.3	DIRECTION / OFF Setting Button.....	69
3.6.1.4	Zones/Fault Selection Box	70
3.6.1.5	Ground Compensation Settings	70
3.6.1.6	CT PT Ratios	71
3.6.2	Generic Characteristics	71
3.6.2.1	Generic MHO Setting Screen.....	72
3.6.2.1.1	MHO Load Encroachment Setting Screen	72
3.6.2.2	HALF MHO Setting Screen	73
3.6.2.3	QUAD Setting Screen.....	74
3.6.2.3.1	QUAD Load Encroachment Setting Screen	74
3.6.3	Relay Library Files	75
3.6.4	RIO Files	76
3.6.5	Impedance - Click On Fault Configuration Screen	77
3.6.5.1	Prefault Dialog Box.....	77
3.6.5.2	Control Dialog Box.....	77
3.6.5.3	Ramp/Shot Options	78
3.6.5.4	CT PT Ratios	78
3.6.5.5	Polar/Rectangular Plot Button	78
3.6.5.6	Auto Set Fault Times button	78
3.6.5.7	Ohms Per Phase/Per Loop button	78
3.6.6	Impedance - Click On Fault Test Screen	78

3.6.6.1	RIO button	79
3.6.6.2	Generic Characteristics button	79
3.6.6.3	Relay Library button	79
3.6.6.4	Binary Input Setting button	79
3.6.6.5	Return to Settings Input Screen button	80
3.6.6.6	Play button.....	80
3.6.6.7	Test All button.....	80
3.6.6.8	Zoom button	80
3.6.6.9	Battery Simulator button	80
3.6.6.10	The Configuration button	80
3.6.6.11	Review Test Report button	80
3.6.6.12	Quick Test option.....	80
3.6.6.13	Independence Test Points option	81
3.6.6.13.1	IEC60255 Test Points option	81
3.6.6.13.2	Origin Test Points option	81
3.6.6.13.3	Shots Test Points option	82
3.6.6.14	Return to Impedance COF Configuration Screen button	82
3.6.6.15	Fault Selection button.....	82
3.6.6.16	Clear Test(s) button.....	82
3.7	Testing Transducers with the STVI Software	82
3.7.1	Transducer Setup Screen	83
3.7.1.1	Nameplate Section	84
3.7.1.2	Type Selection Section.....	84
3.7.1.3	Test Settings Section.....	84
3.7.1.4	Input Range Section	85
3.7.1.5	Output Range Section	85
3.7.2	Transducer Test Screen	86
3.7.2.1	Output Section.....	86
3.7.2.2	Transducer Output Section	87
3.7.3	Testing Transducers	87
3.7.4	Saving Results	88
3.7.5	Watt / Var / Va / Power Factor Applications	88
3.7.5.1	Watt/VAR 1 Element.....	88
3.7.5.2	Power Factor 1 Element.....	90
3.7.5.3	Watt/VAR1 1/2 Element.....	91
3.7.5.4	Watt/VAR 2 Element.....	93
3.7.5.5	Watt/VAR 2 1/2 Element.....	94
3.7.5.6	Watt/VAR 3 Element.....	96
3.7.5.7	Power Factor 3 Element	98
3.7.6	Single Phase Applications	100
3.7.6.1	AC and DC Voltage Transducers	100
3.7.6.2	AC and DC Current Transducers	101
3.7.6.3	Frequency Transducers.....	102
3.8	Testing Differential Relays with the STVI	103
3.8.1	Transformer Nameplate	104
3.8.2	Transformer Differential Tests	111
3.8.2.1	Stablization Test.....	112
3.8.2.2	Timing Test.....	112
3.8.2.3	Pickup Test.....	113
3.8.2.4	Slope Test	114
3.8.2.5	Harmonic Block Test	116
3.8.2.6	Harmonic Shot Test.....	117
4.0	Warranty Statement	118
5.0	Service Data	118
5.1	Preventive Maintenance	118
5.1.1	Examine the Unit.....	118

5.1.2	Upgrading STVI Software	118
5.2	Service and Repair Instructions	119
5.2.1	Basic Troubleshooting.....	119
5.2.1.1	Power Input	120
5.2.1.2	Ethernet Cable.....	120
6.0	Preparation for Reshipment	120
	Addendum A SMRT1	122
	Safety Precautions	123
1.0	Operation	125
1.1	General Description	125
1.1.1	Front Panel.....	125
1.1.2	Side Panel.....	126
1.1.3	Rack Mount Enclosure Rear Panel	126
1.2	Input Power	127
1.2.1.	Input Power Cord	127
1.3	Voltage Current Generator (VIGEN) Module	128
1.3.1.	Convertible Voltage/Current Amplifier.....	128
1.3.2.	Current Amplifier	129
1.4	Binary Input and Output	130
1.4.1	Binary Inputs	130
1.4.1.1	Start, Stop, and Monitor Gates	131
1.4.1.1.1	Dry Contacts Open	131
1.4.1.1.2	Dry Contacts Close.....	131
1.4.1.1.3	Application or Removal of AC or DC voltage	131
1.4.2	Binary Outputs	131
2.0	SETUP	131
2.1	Unpack System.....	131
2.2	Communication Ports	132
2.2.1	PC IN Ethernet Port	132
2.2.1.1	Setting SMRT IP Address for Operation with a PC	132
2.2.1.2	Setting SMRT IP Address for Networks	133
2.2.2	61850/OUT Ethernet Port	133
2.2.2.1	IEC 61850 Operations	134
3.0	Current Sources	134
3.1	Parallel Operation	134
3.1.1	Manual Test Screen - Single Phase Up To180 Ampere.....	134
3.2	Currents in Series Operation	135
4.0	Voltage Sources	136
4.1	Outputs Summed Together	136
4.2	3Ø, 3-Wire, Open-Delta and T-Connection	137
4.2.1	Balanced Open Delta	137
4.2.1.1	Unbalanced Open Delta	137
4.2.2	T-Connection.....	139
4.3	3Ø, 4-Wire, Y-Connection	139
5.0	Warranty Statement	141
5.1	Preventive Maintenance	141
5.1.1	Examine the Unit.....	141
5.1.2	Updating SMRT1 Firmware.....	141
5.2	Service and Repair Instructions	142
5.2.1	Basic Troubleshooting.....	142
5.2.1.1	Input Power	143
5.2.1.2	VIGEN Input Power and Control	143
5.2.1.3	Binary Input and Output.....	146
6.0	Preparation for Reshipment	147
	Addendum B SMRT33/36	149
	Safety Precautions	150

1.0	Operation	152
1.1	General Description	152
1.1.1	Top Panel	152
1.1.2	Front Panel	153
1.2	Input Power	154
1.2.1.	Input Power Cord	154
1.3	Voltage Current Generator (VIGEN) Module	155
1.3.1.	Convertible Voltage/Current Amplifier	155
1.3.2.	Current Amplifier	156
1.4	Binary Inputs and Outputs	157
1.4.1	Binary Inputs	158
1.4.1.1	Start, Stop, and Monitor Gates	158
1.4.1.1.1	Dry Contacts Open	158
1.4.1.1.2	Dry Contacts Close	158
1.4.1.1.3	Application or Removal of AC or DC voltage	158
1.4.2	Binary Outputs	159
1.5	Battery Simulator	159
2.0	SETUP	159
2.1	Unpack System	159
2.2	Communication Ports	160
2.2.1	USB 2.0 Interface	160
2.2.2	PC/OUT Ethernet Port	161
2.2.2.1	Setting SMRT IP Address for Operation with a PC	161
2.2.3	STVI Ethernet Port	162
2.2.3.1	Setting SMRT IP Address for Operation with STVI	162
2.2.4	IN - IEC61850 Ethernet Port	162
2.2.4.1	Setting SMRT IP Address for Networks or IEC 61850 Operations	163
3.0	Current Sources	163
3.1	Parallel Operation	163
3.1.1	Manual Test Screen - Single Phase Up To180 Ampere	164
3.2	Currents in Series Operation	165
4.0	Voltage Sources	167
4.1	Outputs Summed Together	167
4.2	3Ø, 3-Wire, Open-Delta and T-Connection	168
4.2.1	Balanced Open Delta	168
4.2.1.1	Unbalanced Open Delta	170
4.2.2	T-Connection	171
4.3	3Ø, 4-Wire, Y-Connection	171
5.0	Warranty Statement	173
5.1	Preventive Maintenance	173
5.1.1	Examine the Unit	173
5.1.2	Updating SMRT33/36 Firmware	173
5.2	Service and Repair Instructions	174
5.2.1	Basic Troubleshooting	174
5.2.1.1	Power Input	175
5.2.1.2	VIGEN Input Power, Communication and Control	175
5.2.1.2.1	Replacing a VIGEN	178
6.0	Preparation for Reshipment	180
	Addendum C SMRT410	181
	Safety Precautions	182
1.0	Operation	184
1.1	General Description	184
1.1.1	Top Panel	184
1.1.2	Front Panel	185
1.2	Input Power	186
1.2.1.	Input Power Cord	187

1.3	Voltage Current Generator (VIGEN) and Double-Current (DIGEN) Modules	187
1.3.1.	Convertible Voltage/Current Amplifier	188
1.3.2.	Current Amplifier	188
1.4	Binary Inputs and Outputs	189
1.4.1	Binary Inputs	189
1.4.1.1	Start, Stop, and Monitor Gates	189
1.4.1.1.1	Dry Contacts Open	190
1.4.1.1.2	Dry Contacts Close	190
1.4.1.1.3	Application or Removal of AC or DC voltage	190
1.4.2	Binary Outputs	190
1.5	Battery Simulator	190
2.0	SETUP	191
2.1	Unpack System	191
2.2	Communication Ports	191
2.2.1	USB 2.0 Interface	191
2.2.2	PC/OUT Ethernet Port	192
2.2.2.1	Setting SMRT IP Address for Operation with a PC	192
2.2.3	STVI Ethernet Port	193
2.2.3.1	Setting SMRT IP Address for Operation with STVI	193
2.2.4	IN - IEC61850 Ethernet Port	193
2.2.4.1	Setting SMRT IP Address for Networks or IEC 61850 Operations	193
3.0	Current Sources	194
3.1	Parallel Operation	194
3.1.1	Manual Test Screen - Single Phase Up To180 Ampere	195
3.2	Currents in Series Operation	196
4.0	Voltage Sources	198
4.1	Outputs Summed Together	198
4.2	3Ø, 3-Wire, Open-Delta and T-Connection	199
4.2.1	Balanced Open Delta	199
4.2.1.1	Unbalanced Open Delta	201
4.2.2	T-Connection	202
4.3	3Ø, 4-Wire, Y-Connection	202
5.0	Warranty Statement	204
5.1	Preventive Maintenance	204
5.1.1	Examine the Unit	204
5.2	Updating SMRT410 Firmware	204
5.3	Service and Repair Instructions	205
5.3.1	Basic Troubleshooting	205
5.3.1.1	Power Input	206
5.3.1.2	VIGEN Input Power, Communication and Control	206
5.3.1.2.1	Replacing a VIGEN	209
5.3.1.3	Binary Inputs, Binary Outputs and Battery Simulator	210
6.0	Preparation for Reshipment	211
	Addendum D MPRT 8445	212
	Safety Precautions	213
1.0	Operation	215
1.1	General Description	215
1.1.1	Front Panel	215
1.1.2	Smart Touch View Interface	216
1.2	Input Power	217
1.2.1.	Input Power Cord	217
1.3	Voltage Current Generator (VIGEN)	217
1.3.1.	Convertible Voltage/Current Amplifier	218
1.3.2.	Current Amplifier	218
1.4	Binary Inputs and Outputs	219
1.4.1	Binary Inputs	219

1.4.1.1	Start, Stop, and Monitor Gates.....	219
1.4.1.1.1	Dry Contacts Open.....	219
1.4.1.1.2	Dry Contacts Close.....	219
1.4.1.1.3	Application or Removal of AC or DC voltage.....	219
1.4.2	Binary Outputs.....	220
1.5	Battery Simulator	220
2.0	SETUP	220
2.1	Unpack System.....	220
2.2	Communication Ports	221
2.2.1	USB 2.0 Interface.....	221
2.2.2	PC IN Ethernet Port.....	221
2.2.2.1	Setting MPRT8445 IP Address for Operation with a PC.....	221
2.2.3	STVI Ethernet Port.....	222
2.2.3.1	Setting MPRT8445 IP Address for Operation with STVI.....	222
2.2.3.2	Setting MPRT8445 IP Address for Networks or IEC 61850 Operations.....	222
3.0	Current Sources	223
3.1	Parallel Operation.....	223
3.1.1	Manual Test Screen - Single Phase Up To180 Ampere.....	224
3.2	Currents in Series Operation.....	225
4.0	Voltage Sources	227
4.1	Outputs Summed Together.....	227
4.2	3Ø, 3-Wire, Open-Delta and T-Connection	228
4.2.1	Balanced Open Delta.....	228
4.2.1.1	Unbalanced Open Delta.....	230
4.2.2	T-Connection.....	231
4.3	3Ø, 4-Wire, Y-Connection	231
5.0	Warranty Statement	233
5.1	Preventive Maintenance	233
5.1.1	Examine the Unit.....	233
5.2	Updating MPRT8445 Firmware	233
5.3	Service and Repair Instructions	234
5.3.1	Basic Troubleshooting.....	234
5.3.1.1	Power Input.....	235
5.3.1.2	VIGEN Input Power, Communication and Control.....	235
5.3.1.2.1	Replacing a VIGEN.....	237
5.3.1.3	Binary Inputs, Binary Outputs and Battery Simulator.....	237
6.0	Preparation for Reshipment	239
	Addendum E MPRT 2145	240
	Safety Precautions	241
1.0	Operation	243
1.1	General Description	243
1.1.1	Front Panel.....	243
1.1.2	Side Panel.....	244
1.2	Input Power	244
1.2.1.	Input Power Cord.....	244
1.3	Voltage Current Generator (VIGEN) Module	245
1.3.1.	Convertible Voltage/Current Amplifier.....	245
1.3.2.	Current Amplifier.....	246
1.4	Binary Input and Output	247
1.4.1	Binary Inputs.....	247
1.4.1.1	Start, Stop, and Monitor Gates.....	248
1.4.1.1.1	Dry Contacts Open.....	248
1.4.1.1.2	Dry Contacts Close.....	248
1.4.1.1.3	Application or Removal of AC or DC voltage.....	248
1.4.2	Binary Outputs.....	248
2.0	SETUP	248

2.1	Unpack System.....	248
2.2	Communication Ports	249
2.2.1	PC IN Ethernet Port	249
2.2.1.1	Setting SMRT IP Address for Operation with a PC	249
2.2.1.2	Setting SMRT IP Address for Networks	250
2.2.2	61850/OUT Ethernet Port	250
2.2.2.1	IEC 61850 Operations	251
3.0	Current Sources	251
3.1	Parallel Operation	251
3.1.1	Manual Test Screen - Single Phase Up To135 Ampere	251
3.2	Currents in Series Operation	253
4.0	Voltage Sources	253
4.1	Outputs Summed Together	253
4.2	3Ø, 3-Wire, Open-Delta and T-Connection	254
4.2.1	Balanced Open Delta	254
4.2.1.1	Unbalanced Open Delta	255
4.2.2	T-Connection.....	257
4.3	3Ø, 4-Wire, Y-Connection	257
5.0	Warranty Statement	259
5.1	Preventive Maintenance	259
5.1.1	Examine the Unit.....	259
5.1.2	Updating MPRT2145 Firmware	259
5.2	Service and Repair Instructions	260
5.2.1	Basic Troubleshooting.....	260
5.2.1.1	Input Power	261
5.2.1.2	VIGEN Input Power and Control	261
5.2.1.3	Binary Input and Output.....	264
6.0	Preparation for Reshipment	266

1.0 STVI Introduction

STVI is a user friendly interface to control the **Megger SMRT and MPRT** relay test equipment. This manual contains the information that you will need in order to set up and use your STVI with the SMRT or MPRT Relay Test Systems. How the unit operates, some of the different types of testing you can do, and how to save and view your test results with the Smart Touch View Interface software is described. It also covers running the STVI software using the PowerDB software on your PC.

There are two versions of the STVI unit.

- STVI-1 Used with SMRT36 and MPRT8445
- STVI-2 Used with SMRT1 and older MPRT units. The STVI-2 is an STVI-1 with an external Power Over Ethernet power supply and Ethernet interface unit.

Information regarding SMRT MPRT8445 units can be found in the addendums.

1.1 Smart Touch View Interface

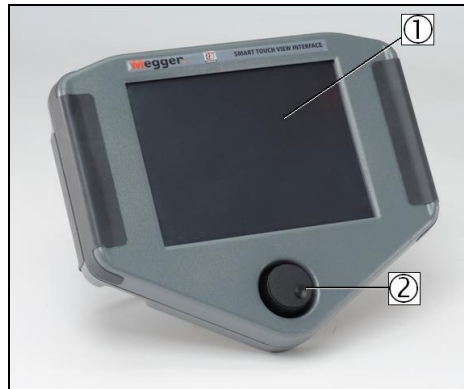

Figure 1 Smart Touch View Interface

1. **TFT LCD Color Display** – this 8.5 inch touch panel display provides high resolution, and features Wide Viewing Angle Technology with high luminance for reading in direct sunlight.
2. **Control Knob** – this knob will adjust values once the box location of the value to be changed is selected.



Figure 2 STVI Rear-View

3. **Built-in Foldout Stand** – the STVI may be operated as a handheld controller, or foldout the built-in stand and use a desktop controller.
4. **STVI Ethernet Port** – this Ethernet port is a 10/100BaseTX PoE (Power over Ethernet) port, and is the SMRT connection port.
5. **USB Interface** – the USB 2.0 Interface requires a Type A connector, and is primarily used as a communication and control port. A USB cable is not provided with the test set or in the optional accessories. For control of the SMRT, an Ethernet cable is provided since the STVI gets its power over the Ethernet cable. Even though the STVI has a built-in virtual keyboard, the user can use a USB keyboard with the STVI, as well as a mouse (including Logitech wireless mouse), keyboard and/or mouse are not provided with the accessories. The USB port is also used to update the firmware in the SMRT as well as update the software in the STVI using a USB memory stick. The STVI USB port does not support memory sticks larger than 2 GB. It may also be used to download test results from the STVI for download into another PC with Power DB software for storage or printing.

1.2 Terminology

The acronyms, terms, and definitions used throughout this manual are described below:

1.2.1 Acronyms

AC	Alternating Current
AVTS	Advanced Visual Test Software
CW	Clockwise (rotation)
CCW	Counter Clockwise (rotation)
DC	Direct Current
GPS	Global Position System
GUI	Graphical User Interface
Hz	Hertz
ID	Identification
I/O	Input / Output
kHz	Kilo Hertz
LCD	Liquid Crystal Display
LED	Light Emitting Diode
MAG	Magnitude
MTA	Maximum Torque Angle
PC	Personal Computer
ROM	Read-Only Memory
RTS	Relay Test System
STVI	Smart Touch View Interface
USB	Universal Serial Bus
VAC	Volts Alternating Current
VDC	Volts Direct Current
VIGEN	Voltage / Current Generator Module
VRMS	Volts Root Mean Square
UUT	Unit Under Test

1.2.2 Glossary of Terms

The STVI display screens prompt the user to select, or set, various values. The values vary depending on the relay under test, and the relay setting screen. Many of the terms used are similar in nature and mean virtually the same thing regardless of the type of relay. For example, the term Time Dial is commonly used to define the time dial setting on the relay

under test. The Time Dial could be on an overcurrent relay, or just as easily be on a under voltage relay. Unfortunately, some of the terms described here may apply to different types of relays in different ways, and thus may not cover every possible relay made. However, it is hoped that this glossary will help the user to understand every setting value on every relay setting screen.

1.2.2.1 **Pickup** (Tap)

A numerical value associated with a tap setting on the relay. **Pickup** or Tap is normally associated with a value of current, voltage, phase angle, frequency, watts or Ohms. It is used to define a setting value, pick up value, or minimum operating point, of the relay under test.

1.2.2.2 **TDM** (Time Dial Multiple)

A numerical value normally associated with a TIME CURVE, or defines the use of a specific time curve from a family of curves. Used when conducting a timing test. The TIME DIAL number also may be used in a Time-Curve algorithm in calculating the theoretical operating time of the relay under test.

1.2.2.3 **Inst.** (Instantaneous Tap)

A numerical value associated with a tap setting on the instantaneous element of the relay. Normally associated with a value of current or voltage, it is used to define a pick up value, or minimum operating point, of the instantaneous element of the relay under test.

1.2.2.4 **Reset Seconds**

It is a numerical value of time, normally associated with electromechanical relays. This is the amount of time required for the operating disk to reset. If multiple timing tests are conducted on a relay, the test system will wait the Reset Seconds value prior to applying the next timing test. Numerical relays also can have programmable reset times to coordinate with electromechanical relays.

 Note, if the Reset Seconds is set too short, and the disk does not completely reset, then timing error will be introduced to the test.

1.2.2.5 **Time Delay**

It is a numerical value of time, normally associated with the minimum operating time of electromechanical instantaneous relays. This is the minimum amount of time delay associated with the closing of the instantaneous trip contacts. When a value is entered, a line will be drawn associated with the time entered in the trip characteristic display. If one of the test points selected by the user is for testing the instantaneous operation, it will be plotted with the other time delay trip points.

 Note that numerical relays also can have programmable Time Delay settings associated with the instantaneous operation.

1.2.2.6 **Test Multiple**

A numerical value normally associated with conducting timing tests. Multiples are normally expressed in terms of whole numbers like 2, 3, 4, etc., times the Relay Pickup, or Tap, value of the relay under test. Fractions of test multiples may also be entered, and the appropriate test values and theoretical trip times will automatically be calculated. If no **Reset Seconds** (see 1.2.2.4) value is entered, then only one timing test point will be conducted when pressing the appropriate STVI Blue Play button. If a Reset Seconds value is entered, after

pressing the first blue play button the test system will perform all the Test Multiples in sequence waiting the Reset Seconds between applications of the entered Test Multiples.

1.2.2.7 **Reach or Diameter**

A numerical value expressed in Ohms. This value is used to determine the “distance”, in Ohms, that the relay under test “sees” either into a line section or a generator.

1.2.2.8 **Angle (Torque)**

A numerical value expressed in degrees. A value used in impedance relays to define the “maximum torque angle” or “line angle” setting of the relay under test (sometimes abbreviated as **Ang.**).

1.2.2.9 **Expected Trip Time**

A numerical value which expresses the operating time of the relay under test, normally used to specify a definite operating time for a given fault value in the testing of multi-zone distance relays.

1.2.2.10 **Winding (1,2,3,4) Tap**

A numerical value associated with the Winding Number i.e. 1, 2, 3, 4, etc., of a transformer differential relay, used to define the tap setting value and test for each winding.

1.2.2.11 **% Slope**

A numerical value which establishes the operating characteristic of a differential relay. The operating characteristic of the differential relay is a line, with a slope defined by the ratio of the operating and restraint values.

1.2.2.12 **% Harmonic**

A numerical value which establishes the percent of harmonic restraint for a harmonic restrained transformer differential relay. This value will be used to determine Pass/Fail during the Harmonic Restraint test.

1.2.2.13 **% Prefault Seconds**

It is a numerical value of time, normally associated with relays which require prefault values prior to applying the fault values. This is the amount of time required for the operating disk to set. to a “normal” operating state, or a microprocessor based relay to be properly polarized prior to applying the fault state. A couple of examples would be an electromechanical voltage relay, or a numerical distance relay. If multiple tests are conducted on a relay, the test system will apply the Prefault Seconds value prior to applying the next test value.

 Note, if the Prefault Seconds is set too short, and the relay may not completely come to rest (if electromechanical), or be properly polarized, then an error will be introduced to the test.

1.3 **Power Over Ethernet Input Power**

The STVI gets Power Over Ethernet (PoE) of 48 Volts DC at 0.5 A from the SMRT33/36/410. The SMRT1 and MPRT units do not provide the 48 Volts DC required by the STVI. The SMRT1, when ordered with the STVI, comes with a PoE power supply. The PoE input voltage may be from 100 to 240 VAC, 50-60 hertz.



CAUTION:

NOTE: The PoE power supply DC voltage is ON when the power supply is connected to a power source. Connect the Ethernet cable to the Data & Power Out port of the PoE power supply to the STVI Ethernet port prior to connecting to a power source.

1.3.1. PoE Power Supply-Input Power Cord

When the STVI is ordered with the SMRT1 or MPRT2145, the power cord that comes with the PoE Power Supply is based upon the power cord selection in the SMRT1 or MPRT2145 style number. Depending on the country, the power supply can come with a NEMA 5-15 male connector, a CEE 7/7 Schuko two prong connector, come with International Color Coded pig-tail wires (light blue, brown and green with yellow stripe) with the insulation jacket stripped ready for installation of the appropriate male connector, or the UK power cord .

North American power cord (part number 620000)

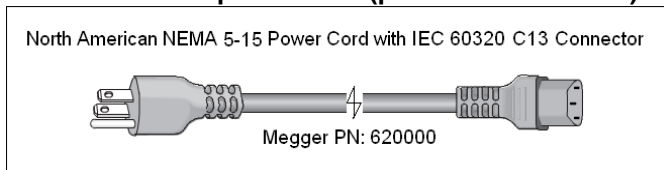

Continental Europe power cord (part number 50425)

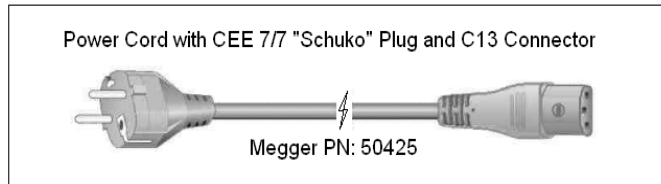

The **International Color Code power cord (part number 15065)** is ready for wiring to the appropriate plug (depending on country). The following colors apply, Brown = Line, Blue = Neutral and Green/Yellow = Ground.

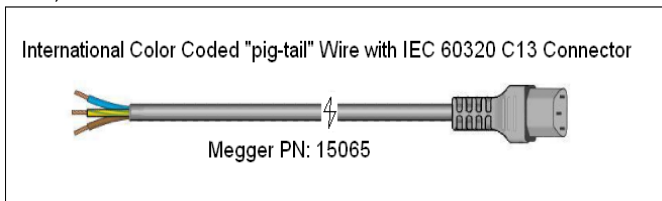

UK power cord (part number 90002-989)

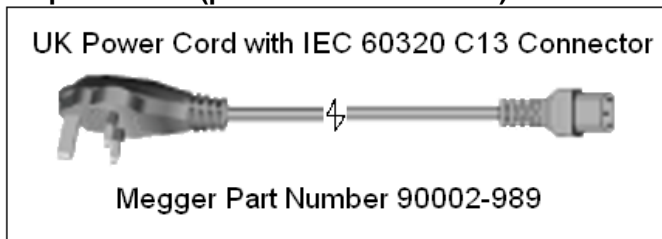

2.0 SETUP

2.1 Unpack System

Unpack the unit and check for evidence of any shipping damage. If there is any visual damage, immediately notify the freight carrier to make a damage claim, and notify Megger of the damage.

2.1.1 Initial Start Up

1. With the Ethernet cable supplied with the unit connect the STVI Ethernet Port on the SMRT33/36/410 unit to the Ethernet port on the top of the Smart Touch View Interface (STVI). For operation with the SMRT1 or MPRT units, connect the **Data & Power Out** port of the PoE power supply to the STVI Ethernet port, and the PoE power supply **Data In** port to the SMRT1 PC/IN port or the MPRT LAN1 port.
2. Before connecting power to the unit, make sure the SMRT POWER ON/OFF Switch is in the OFF position (0). Plug the unit line cord into an appropriate power source and turn the POWER ON/OFF Switch to ON (I). As the SMRT unit goes through its power up sequence, in about a minute the STVI power up screen will appear, then the manual start up screen will appear. For the SMRT1, MPRT2145, or MPRT8415/8430 units, connect the PoE power supply power cord to an appropriate power source.

2.2 Communication Ports

There are two types of communication ports on the STVI, one Ethernet, and two USB ports.

2.2.1 Ethernet Port

There is one Ethernet port on the STVI for connecting to the SMRT or MPRT units. On the SMRT33/36/410 or MPRT8445 units the port is labeled STVI. For the SMRT1 or MPRT2145 it connects to the PoE power supply unit, and the PoE unit is connected to the PC/IN port on the SMRT1 or MPRT2145 (or LAN1 port on the MPRT8415/8430).

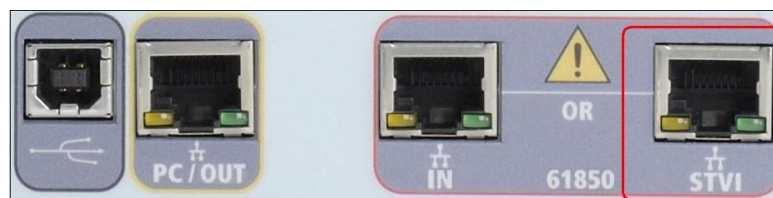

Figure 3 STVI port on SMRT33/36/410 units

2.2.2 USB 2.0 Interface

There are two USB 2.0 Interface ports on the STVI unit. These ports are used for upgrading firmware to the SMRT unit, or upgrading the STVI software using a USB Memory Stick. They may also be used in conjunction with a USB mouse for ease of manual control, even a USB wireless mouse maybe used with the STVI.

! Regarding control of the SMRT with the USB port, see section 2.2.1 in Addendums B, C and D (SMRT33/36, SMRT410 and MPRT8445).

Ethernet Port is a 10/100BaseTX port, and is the primary PC connection port. This port supports MDI/MDI-X auto cross over configuration, which means both standard and

“crossover” Ethernet cables may be used. The SMRT and MPRT8445 units come with a standard Ethernet cable. This port may also be used to interconnect multiple SMRT or MPRT8445/MPRT2145 units together for synchronous multi-phase operation.

2.3 Smart Touch View Interface

The STVI is the manual control and user interface for the unit. All manual entries will be made through the STVI unless the unit is connected to a personal computer.

During the power up sequence the test system automatically does self-test to insure everything is operating properly. Once the system has completed its self checks the Introduction Screen will appear, see the following figure (older model STVI's will have a different Introduction Screen).

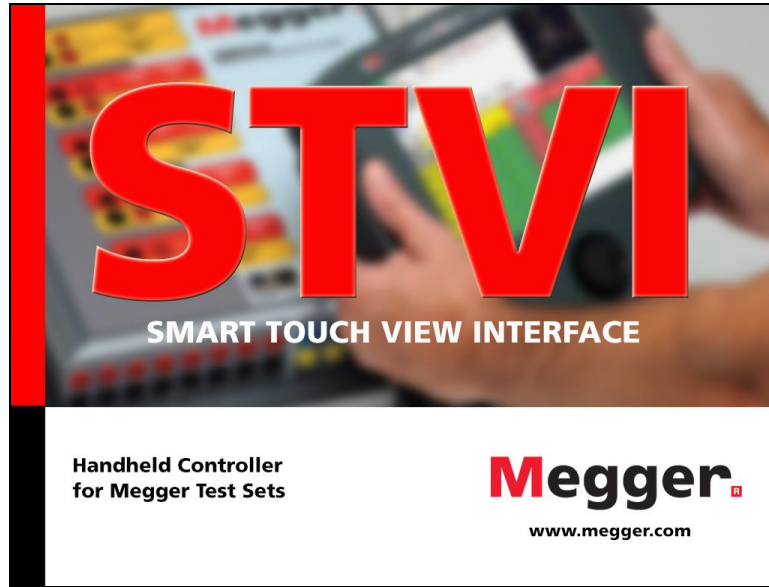

Figure 4 Introduction Screen

Shortly afterward the screen will change to the manual test screen. Depending on how many channels are available the STVI will provide the appropriate number. For example, in the following figure is the power up manual test screen for a 3 channel SMRT33/36 unit.

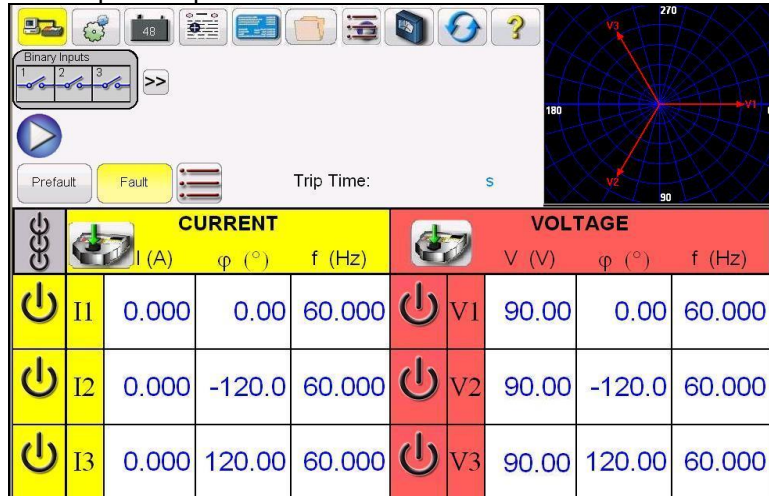



Figure 5 Manual Test Screen

In the upper left hand corner, click on the unit connection button  and the PC or the STVI will auto detect the unit connected and automatically set the IP address through the Ethernet port. The STVI will auto-detect the unit (does not require the user to input an IP

address). Once the STVI detects and connects to the unit, the icon connection will turn green. If using the PC version it too can auto-detect the unit connected to the PC. On the PC version, the unit might not auto detect due to firewall settings. In this case the firewall can be turned off or you can enter the IP address directly using the PowerDB instrument

configuration screen by clicking on the Instrument Setup icon on the PowerDB tool bar . From the Instrument Configuration Screen, shown in the following figure, click off the check mark in the Auto Discover Unit box.

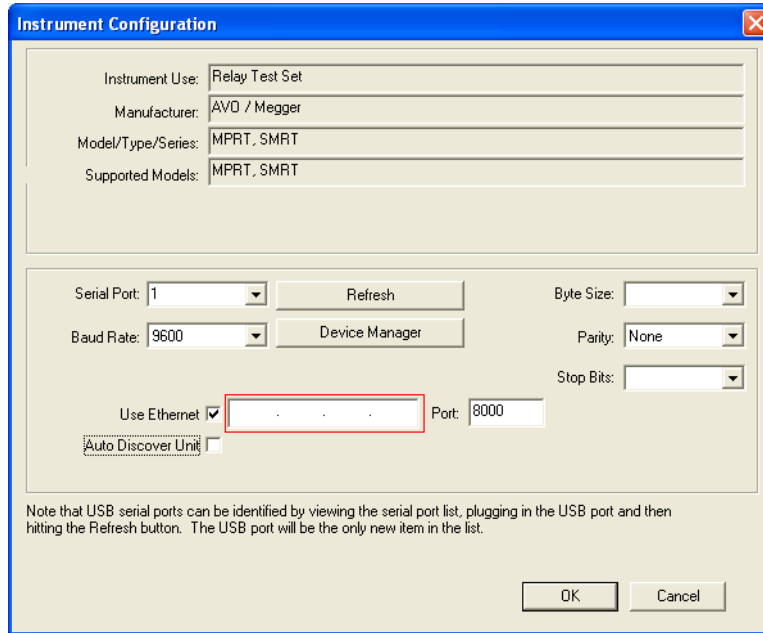



Figure 6 PowerDB Instrument Setup Screen

Here the user can enter the IP address directly into the box highlighted in red. The IP address of the unit can be determined by counting the number of times the Binary Output led flashes at the end of boot up cycle (the address is 169.254. <#flashes>.0). If the unit flashed four times, the address would be 169.254.4.0. Also note that the IP address is also printed on the unit nameplate sticker. If the unit is on a network with a DHCP server, the user must use the Auto Discovery mode.

2.3.1 Configuration

Pressing the Configuration button  will allow the user to configure both the SMRT / MPRT hardware and STVI software for items such as language and phase angle rotation. Pressing this button will display the Configuration screen.

 Note: The following button descriptions vary depending on hardware configuration, and if using an STVI or the PC version of the STVI software. See the following Configuration Screen example.

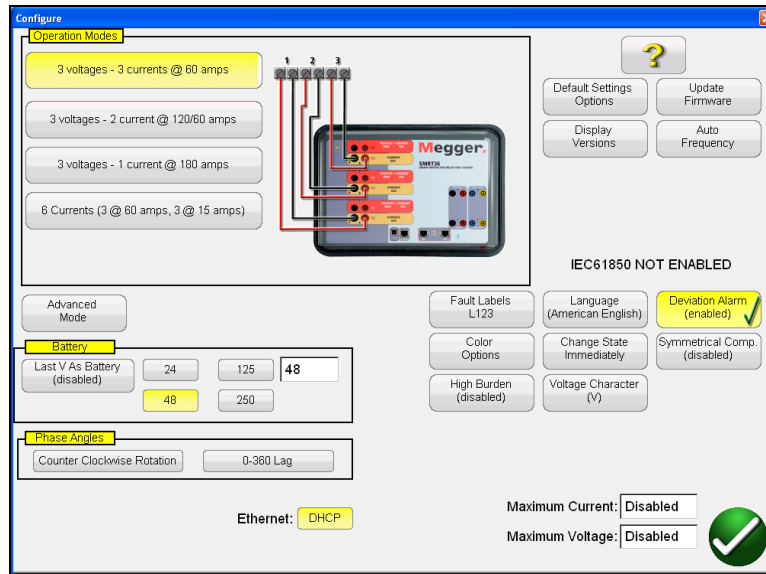



Figure 7 STVI Example Configuration Screen for SMRT36

Note: the picture will change depending on type of unit

2.3.1.1 Operation Modes

The user can select the output configuration. The connection picture will change with the selection indicating to the user how to connect the outputs. With the selection the STVI display will also change in combination with the selected outputs. For example, if a user needs more than 60 amps, the '3 Voltages – 1 Current @ 180 amps' option can be selected and will allow the user to enter the value directly. The display will change to a single current channel and the value entered will automatically be distributed across all available current generators.

2.3.1.2 Battery Simulator

For units with the 'P' System Board Option that includes the battery simulator, the user can either select one of the common battery voltage levels, or enter the desired voltage level in the window provided. Upon returning to the test screen the voltage value will be displayed in the Battery Simulator button . Press this button to turn the output on/off. The button changes color with the change in output. Note: SMRT1 or MPRT2145 units do not have a Battery Simulator.

2.3.1.2.1 Last VIGEN is Battery

Selecting this button will convert the last voltage channel (normally #3) to a battery simulator. This is especially useful if the unit does not have the system board with a battery simulator ('P' option).

2.3.1.3 Phase Angles

Select the desired phase angle display for the Phase Vector Screen. The phase angle designations can be set to 0 to 360 degrees Lead/Lag, or ± 180 degrees (positive angles are leading). The rotation can also be set to either counterclockwise or clockwise rotation. The factory default is 0-360° lagging. Press the Phase Angle select button, and the following screen will appear.

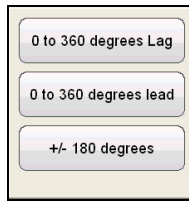

Figure 8 Phase Angle Selection Screen

See section 3.2 for more details on setting phase angle relationships.

2.3.1.4 ? Help Button

Press this button to access the built-in manual for help associated with the Configuration Screen.

2.3.1.5 Default Settings Options

Press this button to get access to the settings options of Save as Default, Restore Default, and Restore Factory default settings.



Figure 9 Default Settings Options

2.3.1.5.1 Save as Default

Press this button and all of the changes made to the Configuration Screen and most of the default values for all screens are now saved as the power up defaults.

2.3.1.5.2 Restore Default

Pressing this button provides the ability to restore the original system power up defaults.

2.3.1.5.3 Restore Factory

Pressing this button provides the ability to restore the original system factory power up defaults.

2.3.1.6 Display Versions (Information Screen)

Pressing this button will display firmware and driver versions and build dates.

 This information is useful when calling Megger for service or technical support related issues.

2.3.1.7 Update Firmware

This button is used to update the SMRT firmware and/or the STVI software.

2.3.1.8 Auto Frequency

In the default Auto Frequency position the SMRT / MPRT will measure and determine the input frequency and automatically set the default output frequency to the line frequency. Other choices are 50 Hz, 60 Hz, and 16.667 Hz. so that the output frequency can be something other than the input line. In addition, the user may select Line Sync so that the output phase angles are in a direct relationship with the positive going zero crossing of the input line frequency. Thus multiple SMRT / MPRT units can be synchronized together without needing a physical interconnection.

 Note: the phase angle accuracy may vary as much as 2 degrees when in Line Sync Mode.

2.3.1.9 Fault (Phase) Labels

This button allows the user to set labels for each phase as displayed in the test report such as ABC, RST, L1L2L3, etc.

2.3.1.10 Language

This button allows the user to select the desired display language. The factory default is English, but may be changed to International English, French, Spanish, or German.

2.3.1.11 Deviation Alarm

This button turns the deviation alarm on and off. When the deviation alarm is on and the waveform has excessive deviation, the alarm will sound.

2.3.1.12 Color Options

Press this button to adjust the colors of the vectors, backgrounds, lettering, etc.

2.3.1.13 Change State Immediately / Change on Zero Cross

Unit defaults to the Immediate Mode where amplitudes, phase angles and frequency changes take place immediately upon command. The Zero Cross Mode is used to force all amplitude, phase angle or frequency changes to take place at the positive going zero crossing of the sine wave (normally used when testing frequency relays).

2.3.1.14 Symmetrical Components

Pressing this button will change the vector display to show positive, negative and zero sequence vectors instead of amplitude and phase.

2.3.1.15 High Burden

Pressing the High Burden button enables the high compliance voltage on the output current channels for test currents below 1 Amp. The default (disabled) mode the 50 Volts is available down to 1 amp. When the output current drops below 1 amp the current amplifier changes ranges automatically and the compliance voltage drops to 15 Volts. If a high compliance voltage is required for test currents below 1 Amp, press this button to enable the 50 Volts.

2.3.1.16 Voltage Character

The character used to define and label the voltage output channels can be either V or U. Press this button to change the character. Be sure to press the Save as Default button to save the changes.

2.3.1.17 Date and Time

Press this button to reset the Date and Time in the STVI. This information is critical for saving tests and test results in the unit internal file manager. The PC version uses the PC time and date.

2.3.1.18 Logging

Select this button to log commands sent to the SMRT / MPRT unit from the STVI.

2.3.1.19 Adjust Screen Brightness

The brightness is adjustable on the STVI. The display will always be visible since hardware limits the brightness from becoming too bright or too dark to be seen. Press this button and use the Control Knob to increase or decrease the brightness. For PC version use the PC screen control to adjust.

2.3.1.20 Ethernet (DHCP) IP Address

As mentioned at the beginning of section 2.2, the STVI will auto-detect the SMRT or MPRT8445/2145 unit (the DHCP mode does not require the user to input an IP address). If the unit is on a network with a DHCP server, the user must use the Auto Discovery mode. Using the STVI, pressing the DHCP button will produce the IP Address Dialog box. As mentioned previously, the IP address of the unit can be determined by counting the number of times the Binary Output led flashes at the end of boot up cycle, or look at the unit nameplate sticker. The address is 169.254.<# flashes>.0. If the unit flashed 9 times, the address would be 169.254.9.0.



Figure 10 STVI Configuration Screen Ethernet IP Address Dialog Box

If using the PC version it too can auto-discover the SMRT / MPRT8445/2145 unit connected to the PC. On the PC version, the PC might not auto detect due to firewall or VPN settings. In this case the firewall can be turned off, or you can enter the IP address directly using the PowerDB instrument configuration screen by clicking on the Instrument Setup icon on the

PowerDB tool bar . Shown in the figure below is the PowerDB Instrument Configuration Screen. Click off the check mark in the Auto Discover Unit box. Here the user can enter the IP address directly into the box highlighted in red.

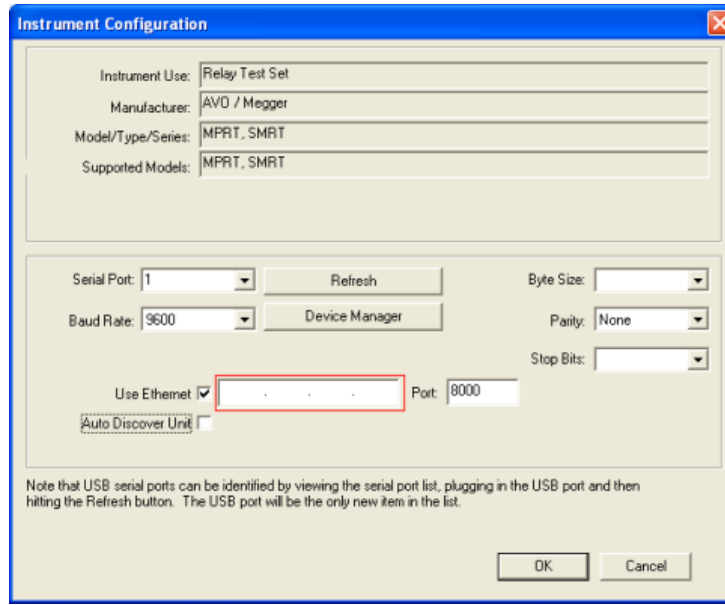



Figure 11 PowerDB Instrument Configuration Screen

2.3.1.21 Advanced - Convertible V/I Selection for Multi-Phase Current Output

In the Configuration Screen, in the Operation Mode sections, (assuming you have a SMRT36 with three VIGEN Modules) select the “6 Currents” mode. Upon returning to the Manual Test screen, the screen will be changed to show 6 current channels. However, should you need more than 3, but less than 6 currents, press this button to select how many voltage channels to convert. For example, you need 4 currents. Press the Advance button, set 1 in the box provided. Going back to the test screen Voltage Channel #1 will now be converted to a current channel. Note that conversion of voltage channels starts with channel #1 and goes up. Therefore, selecting 2 convertible channels will result with voltage channels #1, and #2 being converted to currents leaving voltage channel #3 as a voltage output.



2.3.1.22 Screen Exit



To exit the screen and return to the previous screen press the green  check button (you will see this same button on other screens).

2.4 STVI Setting Amplitudes, Phase Angle or Frequency

Pressing an amplitude, phase or frequency button (right clicking if running on a PC) will display the following pop-up numeric keypad to enter the value you want to change.

2.4.1 Numeric Keypad Entry

The numeric keypad entry provides an interface to the user when entering values in the various screens. Touching a data entry window (Amplitude, Degree or Frequency) on the STVI (right mouse click in the PC version) will activate the Numeric Keypad. Use the numeric keys to type in the value you want and press either the  button or the Balance  button.

Pressing the clear all  will clear the value you just entered. Pressing the clear last digit  button will clear the least significant digit of the value in the display window.

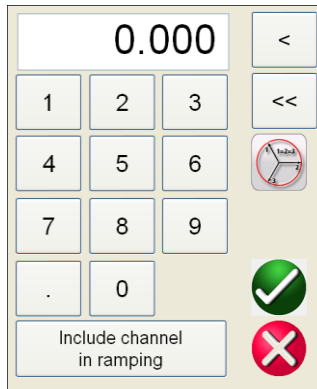







Figure 12 STVI Numeric Keypad

The  button will enter the value and take you back to the test screen. Press the Balance  button if you want all the voltage or currents values to be the same amount. If setting phase angles, and you want all three phases to be shifted the same amount from the defaulted values, enter the amount of phase shift desired in the A Phase window, and press . For example, the default is 0, 120 and 240 degrees. Press on A phase current phase angle and enter 30, press , and the test screen will now show 30, 150, 270 degrees. Pressing Cancel  will return the user to the previous screen that is in use. Pressing **Include channel in ramping** will select that value to ramp when using the control knob.

2.4.2 Include Channel in Ramping

When this button is pressed the window around the channel magnitude is highlighted indicating that it is now set to be ramped manually using either the Control Knob on the STVI, or the up down arrows/mouse wheel on the PC keyboard (PC version). If the channel is already selected for ramping, this button will be labeled 'Remove channel from ramping'. The magnitude may now be ramped up or down using the default increment setting. If the user wants to ramp more than one channel, change the increment, or change the value to be ramped (Amplitude, Phase or Frequency), on the STVI display screen press the Manual Ramp Options button (Control Knob or Up Down Arrows Icon) to display the following screen.

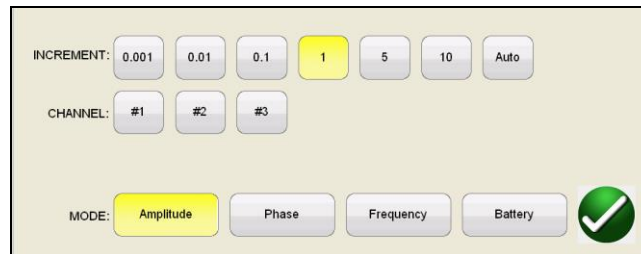

Figure 13 Channel Increment Selection Screen

INCREMENT– Select the desired increment. Color change will indicate the value selected.

CHANNEL – Select the desired channel(s). The channel button will change color indicating the selected channel(s) to be ramped.



MODE – Select Amplitude, Phase, Frequency, or Battery as the value to be ramped. Press or click on the green check button to return to the test screen. One click on the STVI Control

Knob or one press of the Up Down arrow on the PC keyboard will change the output by the Increment setting. If the Auto Increment button is selected the STVI will automatically select the increment depending on how fast the control knob is being rotated, the faster the rotation the larger the increment (does not apply when ramping the Battery Simulator).



2.4.3 Control Knob

The control knob will change the values after touching the display to highlight the value that requires ramping. Clockwise rotation increases and counterclockwise decreases. In the Auto Increment Mode the control knob uses a speed control algorithm to provide fine adjustment, with a slow rotation (one click equals 1 digit of the lowest increment level for the value being ramped), and a larger step adjustment with a faster rotation. The Control Knob can also be used to scroll up and down when viewing the test results in the Add Results and View Results screens, or when viewing the Help screen.

2.4.4 Setting Default Voltage Outputs

The STVI comes with factory default settings, which can be changed to suit the user. Using the numeric keypad entry as described above, select the first voltage channel and enter the desired phase to neutral (earth) value, for example; 67. Press the Balance  button, the green  check button, and all channels will now have a setting of 67 volts. Select the Configuration button, and then select Save as Default (see section 2.3.1.5 Save as Default). The next time the unit is powered up, the default voltage values will all be at 67 Volts.

2.4.5 Setting Default Current Outputs

Similar to setting the default voltage values, the Default Current may be changed to suit the user. Using the numeric keypad entry as described above, select the first current channel and enter the desired phase to neutral (earth) value, for example; enter 1, Press the Balanced  button, and  button, and all channels will now have a setting of 1 Ampere. Select the Configuration button, and then select Save as Default (see section 2.3.1.5 Save as Default). The next time the unit is powered up, the default current values will all be at 1 Ampere.

2.4.4 Virtual Alphanumeric Keypad

The virtual alphanumeric keypad allows the entry of ASCII text into the appropriate STVI windows. This keypad is used to enter names for the binary inputs and outputs, names for each state in the Sequence Test, or file names in the file management screen.

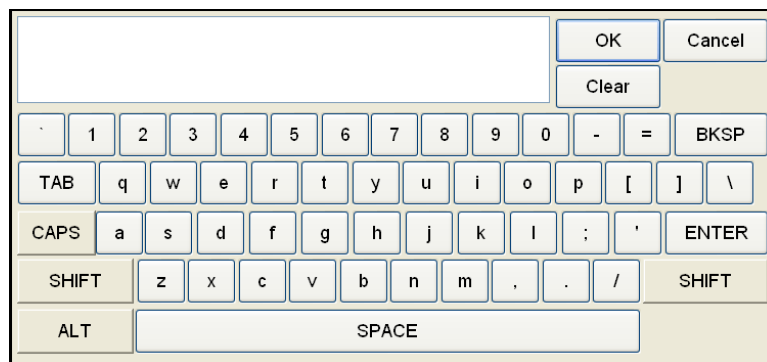

Figure 14 STVI Keyboard

2.5 STVI File Management

The file management display is used by the STVI to access files stored in the STVI's internal memory. This display will allow test files to be loaded, make or change directories, rename files and directories, delete files and directories that were created by the user. To access the File Management system, touch the File Folder icon top center of the test screen. This icon only appears on the STVI (not on PC version). It provides the user the ability to save tests, or open saved tests. If using the PC version users will have the PowerDB file system to save test (job) files (see PowerDB Help). For STVI users' pressing on the File Folder presents the user with the following tool bar. It defaults with the Save Current Form File Folder highlighted.



Figure 15 STVI File Folder Tool Bar

! Note: Pressing the Power ON/OFF **⏻** button will power down the STVI but is not required for a safe shutdown.

Pressing on the highlighted folder will provide the user with the following file explorer.

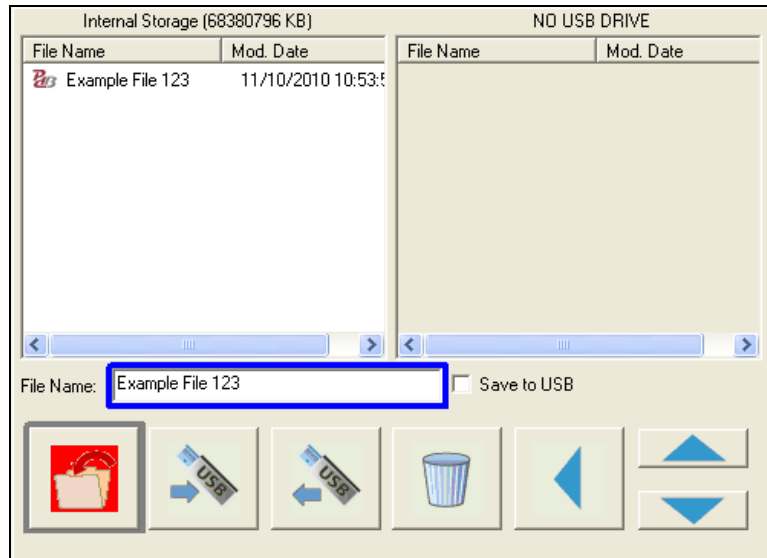





Figure 16 STVI File Folder Explorer

Press in the File Name window and the user will be provided with the virtual keyboard to enter a file name. The file can then be saved to the internal memory or saved to a USB memory stick. This same window is also used to open saved files. To save results directly to a USB memory stick check the Save to USB button. To transfer test results from the STVI to a USB memory stick use the up down blue colored buttons to selected the desired test result to be transferred, and then press on the \Rightarrow USB button. To retrieve a test file from a USB memory stick press on the \Leftarrow USB button to retrieve the selected file from the list of files that appear in the right hand window. To delete a file use the up down arrows to highlight the file, then press on the trash can icon. The left pointing blue arrow \Leftarrow is the exit button to go back to the test screen. To open an existing test file, from the File Folder tool bar, press the Open

File Folder icon . The user will be presented with the File Folder Explorer. Use the up down blue arrows buttons to highlight the desired file to be opened, and then press the Open File Folder button in the lower left corner. The user will be presented with a menu bar to open

a New Test, or to open the file selected showing the date and time of the file saved. Pressing the date / time button will open the saved test. To view the saved results press the  More button in the upper right display next to the vector screen, then press the View Report  button.

3.0 STVI – Basic Operating Descriptions

This section describes basic operating procedures for using the STVI with the SMRT for such applications as basic pickup or dropout, basic timing test, paralleling current outputs, conducting harmonic restraint tests, series of potential sources to provide higher than rated potential, and forming various three phase voltage outputs.

3.1 STVI / PC Manual Test Screen

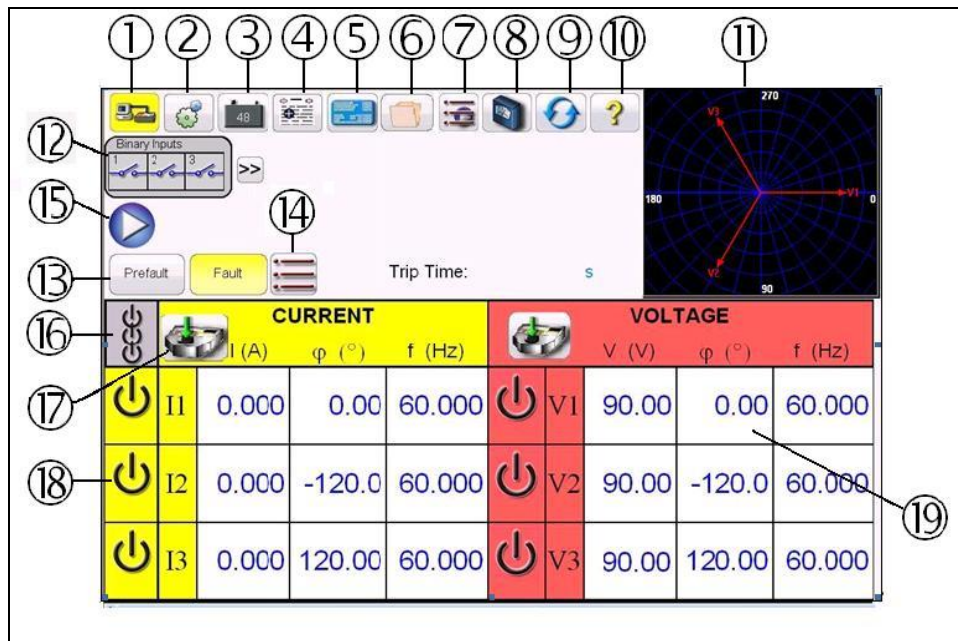



Figure 17 Manual Test Screen

3.1.1 PC or STVI to SMRT connection button

Click on the button and the PC or the STVI will auto detect the SMRT unit connected and automatically set the IP address through the Ethernet ports. If the button shows two red Xs it indicates that there is no communication to the SMRT. If the background color is yellow it indicates that the unit is 'on-line' and ready for operation. When connection is made (commands sent) the background color will change from yellow to green. When in other test

screens a house  icon will appear. Pressing the house icon will return you to the manual test screen.

3.1.2 The Configuration button

Press the button to go to the STVI Configuration Screen. See Section 2.2.1 Configuration for more information of the Configuration Screen.

3.1.3 Battery Simulator button

The Battery Simulator button – Turns the Battery Simulator ON and OFF by pressing the button, the background color changes red for ON and gray for OFF. The voltage to be applied is displayed in the button and can be changed by pressing the configuration button.

3.1.4 Add To Report button

This button will add the present test result to the report. It also displays the report and allows the user to name the test, enter limits, comments or deficiencies. Reports can be saved to the STVI internal memory and transferred to PowerDB via a USB memory stick. Previous tests results can be loaded and the 'Retest' option can be used to repeat the test using the same parameters as the previous test.

3.1.5 Nameplate button

To access the nameplate data window press this button. Here the user can input import information relative to the relay under test such as manufacturer, model number, serial number, CT and PT information.

3.1.6 File Folder button

To access the File Management system, touch the File Folder top center of the test screen. This icon only appears on the STVI (not on PC version). It provides the user the ability to save tests, or open saved tests, see Section 2.5 STVI File Management section for more information.

3.1.7 Test List button

Press this button to access the list of tests that are available. The tests that are available are Ramping, Timing, Sequence, Impedance, Differential, and for those units equipped with the Transducer Hardware Option the Transducer Test. See the following descriptions

3.1.7.1 Ramp button

Press either the I Ramp or V Ramp buttons to go to the Ramp Test screen. This button is used for doing pick up and drop out tests on any type of relay. It can also be used to perform a general purpose linear step ramp, pulse ramp, or pulse ramp binary search.

3.1.7.2 Timing Test button

There are three Timing Test buttons, I (Overcurrent) V (Over/Under Voltage), and f (Under/Over Frequency). Press the appropriate button to go to the desired Timing Test screen to easily time overcurrent, under/over voltage and frequency relays. The STVI software has IEEE and IEC standard time curve algorithms built-in. In addition, it includes time curves and time curve algorithms for hundreds of different specific relays selectable by manufacturer, model number, and curve shape (inverse, very inverse, definite time etc.).

3.1.7.3 Sequencing 1, 2, 3..9 button

Press this button to go to the Sequencing Test screen used for testing reclosing type relays, setting up multiple vectors and general multi-state sequencing.

3.1.7.4 Impedance button

Press this button to go to the Click On Fault relay test screen for testing impedance relays.

3.1.7.5 Differential button

Press this button to go to the Transformer Differential test screen for testing three phase current differential relays.

3.1.7.6 Transducer button

Press this button to go to the Transducer test screen for testing single phase and three phase transducers. This software feature only works with units that have the Transducer Hardware Option installed.

3.1.8 Meter Mode button

Pressing this button will turn the meter mode on (for displaying metered amplitudes). When the meter mode is on the STVI will displayed the measured output amplitudes in real-time.

3.1.9 System Reset button

Pressing this button will reset the unit back to power up default settings. Use this button to reset the VIGENS after they have alarmed off due to either a short circuit on the voltage channels, or an open circuit on the current channels.

3.1.10 Help button

Pressing this button will provide Help for both software and hardware. Some test screens the Help button is sensitive to the test. For example, in the Click On Fault Impedance test screen pressing the Help button will bring up information relative to testing impedance relays.

3.1.11 Phase Vector Screen

This display shows the phases and angles of the test values. Pressing on the screen display provides a full screen display of the test vectors with amplitudes and phase angles. Pressing it again reduces it back to its original size. If used with the Symmetrical Components (see Configuration button) the display will display the positive, negative and zero sequence component values.

3.1.12 Binary Input Dialog Box

The Binary Inputs selection bar and More button – The first 3 binary inputs are displayed showing their present state. Pressing binary input windows #2 and above will display the dialog shown in Figure 18A. For conducting a timing test, press binary input #1 will display the dialog shown in Figure 18B.

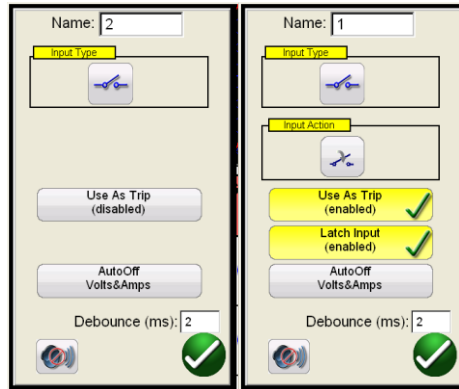



Figure 18 A Binary Input #2 Monitor Mode / 18B Binary Input #1 Time Trip Mode

Binary Input #2 in Monitor Mode the unit is sensing for closing of normally open relay contacts, as displayed by the icon in the Input Type window, or opening of normally closed relay contacts. When the contacts close the LED for the selected binary input will light. If the horn button  is selected on, the horn will sound. If a normally closed contact opens the light will go out (with horn on, the horn will go off). To sense voltage press the Input Type contact icon and it changes showing a voltage sine wave . In Voltage Sensing Mode the unit is sensing the application or removal of an AC or DC voltage. For Timing Tests press either binary #1, or press the **Use as Trip (disabled)** button in binary #2, and the dialog box changes to **Use as Trip (enabled)**. The default settings are dry contacts as indicated by the Input Type, and Input Action defaults to show the Closing of the Normally Open contacts. To change to the opening of Normally Closed contacts press the Input Action icon and it changes to show closed contacts opening. Pressing the **Auto Off** button will provide the user three selections; **Voltage**, **Current**, or **Voltage & Current**. This provides auto off of the voltage, current or voltage & current channels upon tripping of the relay. For most timing applications the timer should be set to **Latched Input (enabled)** mode, which means the timer will stop on the first contact closure. The **Latched Input (disabled)** mode means if the contact bounce the timer will include the bounce time.

The Debounce time is set in milliseconds. The trip contacts must stay closed for the bounce time for the time test to be true. If the contacts open in less than the set bounce time the timer

will continue to run. Once the input condition is true then the time test will conclude. The trip time displayed will be the total test time less the debounce time.

3.1.12.1 Binary More button

Pressing or clicking on the binary more button (next to binary input button) reveals more Binary Input and Output options.

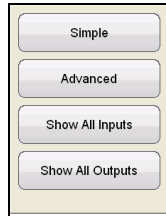



Figure 19 Binary Input and Output Options

3.1.12.1.1 Simple Mode button: The unit defaults to the Simple Mode where only 3 binary inputs (SMRT1 will show 1) are shown.

3.1.12.1.2 Show All Inputs button: Press or click on the Show All Inputs button to reveal all the Binary Inputs that are available and the first two Binary Outputs (SMRT1 will show 1).

3.1.12.1.3 Show All Outputs button: Press or click on the Show All Outputs to reveal all 6 Binary Outputs (or the maximum available) and the first 6 Binary Inputs (if available). To set a Binary Output press or click on the desired binary output, and select Close to close the contact (the default is Open).

3.1.12.1.4 Advanced button: Press or click on the Advanced button and the first 6 Binary Inputs are provided with the first 4 Binary Outputs, plus the Waveform selection button .

3.1.12.1.4.1 Waveform selection button: Press or click on the Waveform selection button. The unit defaults to the 1 position, which provides a sine wave with the fundamental power up default frequency. The user can define up to four waveforms, the default 1 (Fundamental), plus a Second (2), Third (3) and Fourth (4) Waveforms. All four waveforms will be summed together to create a complex waveform from any, or all, of the selected outputs. If no value is entered for the second, third or fourth waveforms then the output will simply be the Fundamental default frequency sine wave. Any amplitude, phase angle or frequency can be specified for each of the four waveforms. This feature is normally used when generating a second, third or fifth harmonic waveform when testing harmonic restraint transformer differential or generator neutral protection relays.

3.1.13 Prefault / Fault buttons

Pressing these buttons will toggle and set the Prefault and Fault amplitudes, phase angles and/or frequencies. If the outputs are on, toggling between the two will apply the prefault and fault values repeatedly with each toggle. This is an especially helpful tool for the user who has to adjust mechanical contacts. It is also used in conjunction with the following Items 14, 15 and 18 for simple timing tests.

3.1.14 Maximum Test Time/Prefault Time/Post Fault Time Settings button

Pressing this button will present a setting window, which allows the user to enter the amount of time in seconds that the Maximum Test Time, Prefault Fault and Post Fault Time values should be applied. When the timing test is started, the time window will start counting down

starting from the Prefault value. When the prefault time has lapsed the Fault values will be applied to the relay under test and the Timer window will start counting until the relay trips. When the relay trips, the Timer will stop and display the operating time of the relay, and the outputs will stay on for the Post Fault Time value entered. If the Auto Off is enabled in the Binary Input configuration screen the outputs will turn off immediately after the operation (see 3.1.12 Binary Input Dialog Box section). If the Auto Off is not enabled the outputs will still turn off at the end of the Post Fault time setting. If the relay has not tripped by the Maximum Test Time setting the test will stop and outputs will turn off automatically.



3.1.15 Play button

Pressing or clicking the blue play button will apply the prefault vector, start the countdown of the Prefault Time setting, then step to the Fault values and look for the relay under test to operate.

3.1.16 All ON/All OFF button

Pressing or clicking on this button either turns all of the selected outputs ON, or if one or more of the outputs are ON, it will turn all of the outputs OFF. The center color of this button changes to green when one or more outputs are ON and indicates that pressing the button will turn all outputs off, with the exception of the Battery Simulator. To turn off the Battery Simulator press the Bat SIM button. This button is also used when ramping the battery simulator output.

3.1.17 Manual Ramp Options button

If using the PC version the  buttons will be displayed. If using an STVI controller the Control Knob icon  will be displayed. Pressing either of these two will present the user with a window to select the desired level of increment for manually ramping the outputs, the desired channel(s) to be ramped, and what is to be adjusted (amplitude, phase angle or frequency). If using the PC version use the keyboard up down arrow keys (or the mouse wheel) to manually adjust the selected value(s) at the desired increment level. If using the STVI one click on the Control Knob equals the increment setting. When ramping phase angles, the Up arrow key ramps the phase angle in the counterclockwise direction, and the down arrow key ramps in the clockwise direction. If the Auto Increment button is selected the STVI will automatically select the increment depending on how fast the control knob is being rotated; the faster the rotation the larger the increment.

3.1.18 Channel ON/OFF Selector button

This button works in conjunction with the # 16 All ON/OFF button. Pressing the button the center of the button changes color indicating the output is selected to turn ON. After pressing the All ON button turns the selected outputs on. Pressing the channel button individually turns the selected channels ON and OFF after the All ON/OFF button is ON. This allows the user to turn individual outputs ON and OFF without affecting other channels.

3.1.19 Channel Amplitude, Phase Angle and Frequency buttons

If using the PC version, a right mouse click in the selected window will present the user with a numeric keypad and dialog box window for setting either individual values or setting multiple values swiftly and easily. For example, to change the default voltage values for all three phases, enter the desired voltage value in the entry window and then press the Balance

 button. All of the values will change to the desired output voltage. The same is true for both Phase Angle and Frequency.

3.2 Setting Phase Angle Relationships

Consider each V/I Generator module as a vector generator. Each module has an internal zero reference to which it references its phase angle settings as displayed on the STVI. This applies to phase angle settings between the voltage and current outputs. When setting a phase angle between two outputs, it is recommended that one output be set at 0° and the other output be referenced to the 0° . This is for operator convenience only. When setting an angle, the operator has a multiple of choices, depending on the Default Phase Angle setting, see 2.3.1.3. In the engineering world and in the following figures, the lagging diagram displays negative rotation and will create negative sequence components, while the Lead and ± 180 diagrams display positive rotation which is normal system activity.

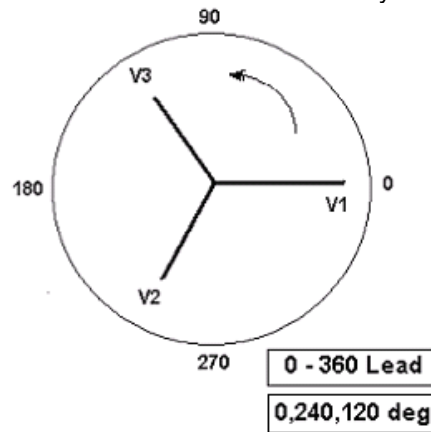

Figure 20 Positive Phase Rotation Diagrams

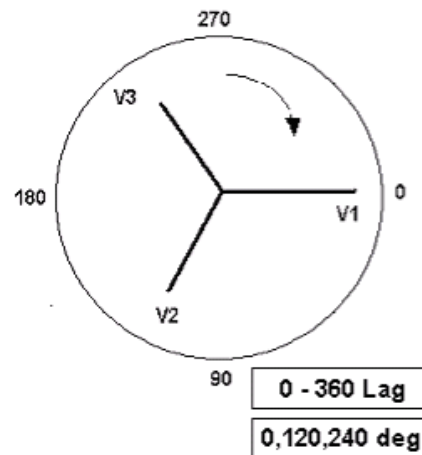

Figure 21 Negative Sequence Phase Rotation Diagrams

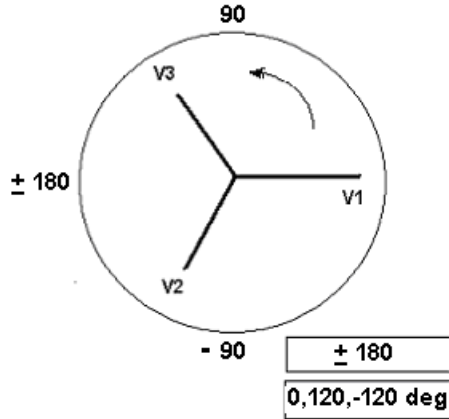
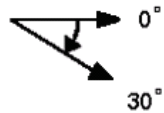
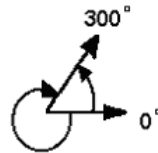

Figure 22 Positive Phase Sequence Rotation Using $\pm 180^\circ$

For example, using 0-360 Lag (0, 120, 240) setting an angle of 30° between the two outputs would look like:



The reference output is 0° and the second output is rotated 30° clockwise. In other words, the angle is lagging the referenced source by 30° . Conversely, if the angle decreases in the counterclockwise direction from 359.9° toward 0.0° , for a setting angle of 300.0° , the second output would look like:



The reference output is 0° and the second output is rotated to 60° in the counterclockwise direction. In other words, the second output lags the reference output by 300° or leads it by 60° . The user may default to phase angles to $\pm 180^\circ$ with the - (negative) angles lagging and the + (positive) angles leading. Therefore, to set an angle of $+ 10^\circ$ leading, the vector relationship would be:

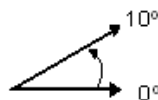

3.3 Current Sources

3.3.1 Parallel Operation

Each SMRT current amplifier is capable of providing 30 Amperes continuous. The SMRT33 and MPRT8445/2145 units can provide a maximum of 45 Amps, while the SMRT1, SMRT36 and SMRT410 units can provide up to 60 amperes, per phase for 1.5 seconds for testing instantaneous trip elements. When more than 30 amps single phase is required for long durations, or more than 60 Amps for testing instantaneous elements, two or more current

channels may be connected in parallel to provide 60 or 90 Amperes continuous (SMRT36), and up to 120 or 180 amperes for 1.5 seconds.

! Note: If an **F** or **C** appears in the 5th digit of the style identification number (i.e. 30P1**F**0A0S1) the current returns are floating (isolated from each other and ground). Those units with a style number **G** or **E**, the current returns are common together internally and connected to earth ground.

To parallel the current channels of the unit, perform the following:

If using the sleeved multi-lead current test leads (part number 2001-396), all of the black return leads are interconnected together inside the sleeve so they will all share the return current together. Connect each current channel to the relay under test (both red and black terminals to the load). Each Megger test lead is rated for 32 Amperes continuous. If using test leads other than those supplied by Megger insure that the wire has sufficient size to carry the test current.

! For the earth grounded common return (G or E) units, there is an internal common ground between the current channel return terminals. If using separate individual test leads, all of the return leads will need to be common together at the load as shown in the following figure. By not connecting a return lead to all of the current channels in use, part or all of the return current will be forced through the internal ground. That means with a 3 channel unit up to 180 Amperes could be forced through the internal common ground, and may cause damage to the internal common returns. Therefore, it is important that the parallel connections must be made at the relay. See the following figure.

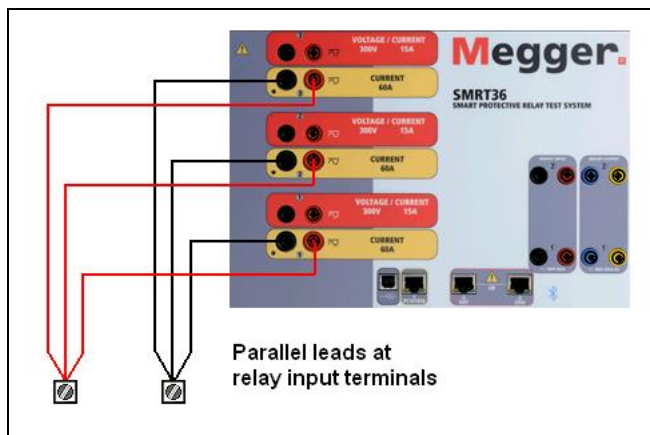

Figure 23 Parallel of Three Current Outputs (SMRT36)

3.3.1.1 Manual Test Screen - Single Phase Up To 180 Ampere

For SMRT36 users, go to the Configuration screen and select the Operating Mode of **3 Voltages – 1 Current @ 180 amps**. Note for SMRT410 and MPRT8445 users there is a similar single channel option available. For MPRT8415/8430 users, you will need to set output currents similar to the older TVI by manually setting all the currents in phase. For SMRT and MPRT8445 users, when you return to the manual test screen there will be one current channel displayed, as shown in the following figure.

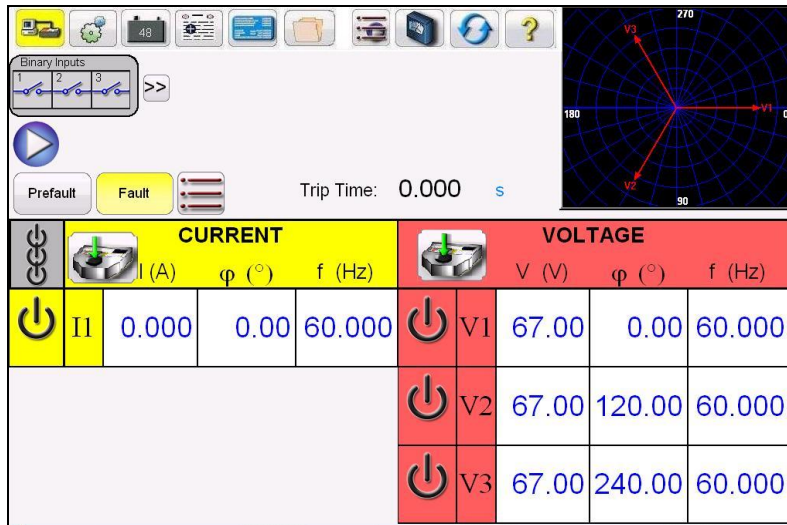

Figure 24 Manual Test Screen – Single Phase Operation

The STVI will automatically set all three currents in phase with each other and divide the current equally between the three current amplifiers. When setting an output, simply enter the value of the desired output current. For example, for an output of 75 Amperes, enter 75. If using a SMRT33/36 with 3 current channels, each current amplifier will be providing 25 Amperes. The current can also be phase shifted. Simply enter the desired phase angle and all three currents will be phase shifted together.

If two current channels that are to be used in parallel, leave the unit in the default three phase configuration. Connect the two current outputs to the load as shown in the following figure.

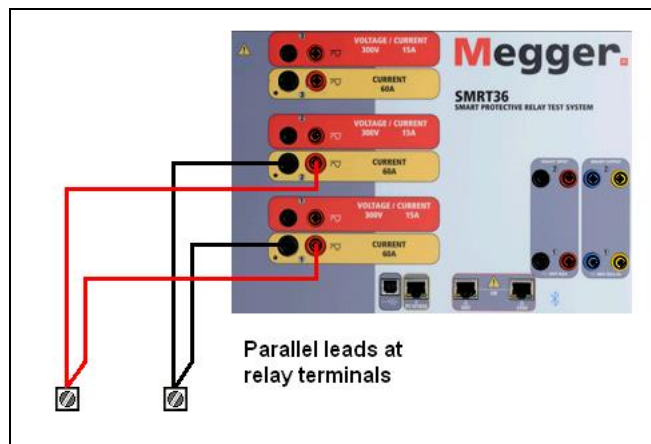



Figure 25 Two Currents in Parallel (on SMRT36)

Set each channel to one-half of the output requirement.  Be sure and **set current channel #2 to 0 degrees** so that it will be in-phase with current channel #1. With both current channels selected, turn output on by pressing or clicking on the ALL ON/OFF button. **Always** use the ALL ON/OFF button to turn both current channels on and off together. For manually ramping outputs, if using the PC version of the STVI software the \updownarrow buttons will be

displayed. If using an STVI controller the Control Knob icon  will be displayed. Pressing either of these two will present the user with a window to select the desired level of increment

for manually ramping the outputs, the desired channel(s) to be ramped, and what is to be adjusted (amplitude, phase angle or frequency).

3.3.2 Currents in Series Operation

Two current channels may be connected in series in order to double the available compliance voltage. High impedance electromechanical ground (earth) overcurrent relays have always been difficult to test at high multiples of tap due to the winding impedance and saturation characteristics. The peak voltage required can exceed the maximum output voltage of one SMRT / MPRT8445 or MPRT2145 current output channel, depending on the required test current. By connecting two current outputs in series, the compliance voltage is doubled, providing higher test currents through the high impedance load.

There are two methods to series currents together. For the **floating output** (F or C) models connect the two current amplifiers in a “push-push” configuration as shown in the following figure.

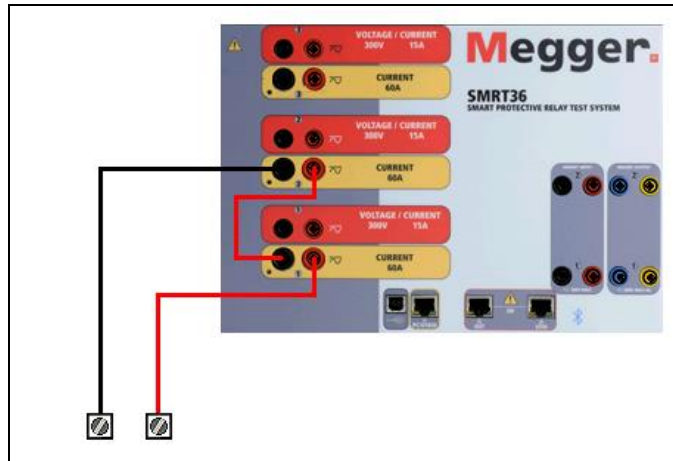



Figure 26 Series Two Currents with SMRT36 Floating Outputs

The two current channels that are to be used in series set each to the same test current magnitude, and phase angle. Select both current channels and turn output on by pressing or clicking on the ALL ON/OFF button. **Always** use the ALL ON/OFF button to turn both current channels on and off together. For manually ramping outputs, if using the PC version of the STVI software the $\uparrow\downarrow$ buttons will be displayed. If using an STVI controller the Control Knob

icon  will be displayed. Pressing either of these two will present the user with a window to select the desired level of increment for manually ramping the outputs, the desired channel(s) to be ramped, and what is to be adjusted (amplitude, phase angle or frequency).

To series the current channels of the **common grounded returns** (on the G or E model top cover the black return terminals are connected with a black line and the ground symbol), perform the following:

Connect the Red output terminals of the two current channels to the relay under test. Even though the two returns associated with the current channels are connected internally with the common returns, place a jumper (PN 2001-573) externally as shown. This will insure that the internal common leads will not be damaged should more than 30 Amps be applied.

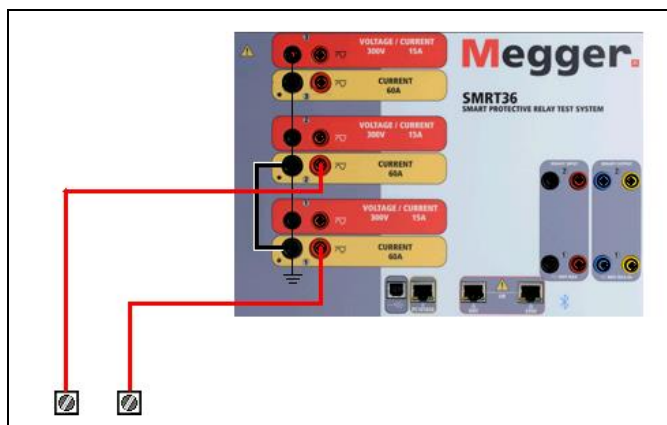



Figure 27 Series of Two Current Channels with SMRT36 Grounded Common Returns

! NOTE: One current channel should be set to 0 degrees and the other current channel should be set to a phase angle of 180 degrees so that the two compliance voltages add across the load. DO NOT attempt to series more than two currents together on a grounded common returns unit.

The two current channels that are to be used in series set each to the same test current magnitude. Initiate the two current channels simultaneously by pressing the ALL ON/OFF button. **Always** use the ALL ON/OFF button to turn both current channels on and off together. For manually ramping outputs, if using the PC version of the STVI software the \updownarrow buttons will be displayed. If using an STVI controller the Control Knob icon  will be displayed. Pressing either of these two will present the user with a window to select the desired level of increment for manually ramping the outputs, the desired channel(s) to be ramped, and what is to be adjusted (amplitude, phase angle or frequency).

3.4 Voltage Sources

3.4.1 Outputs Summed Together

Two voltage channels may be used to sum the voltage outputs to obtain higher than rated voltage provided the load is ungrounded. Connect the load between the voltage channel posts, set V_1 Phase to 0° and set V_2 Phase to 180° . The voltage outputs will add so the total voltage is the sum of the two voltage amplitudes, V_1 and V_2 as can be seen in the following diagram.



! Note: If an **F** or **C** appears in the 5th digit of the SMRT style identification number (i.e. 30P1**F**0A0S1) the voltage returns are floating (isolated from each other and ground). Those units with a style number **G** or **E** the voltage returns are common together internally and connected to earth ground.

For the floating common units the user must connect the associated voltage channels black common returns together, when series operation is required (see the following figures). Remove external commons when testing is completed. DO NOT attempt to series more than two voltage channels together, since the voltage leads are rated for a maximum of 600 Volts.

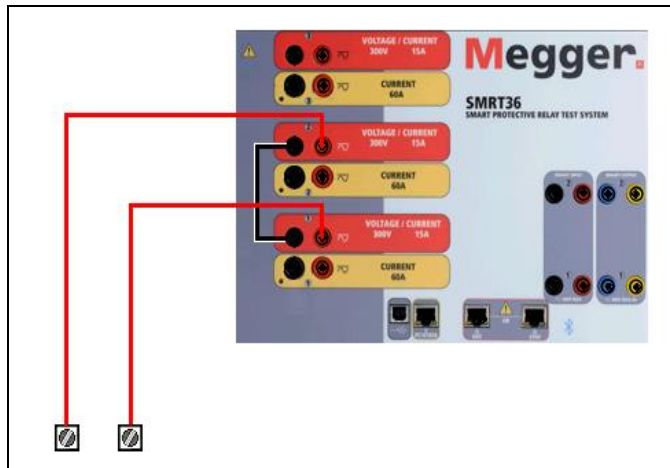

Figure 28 Series of Voltage Channels for SMRT36 Floating Ungrounded Common Returns

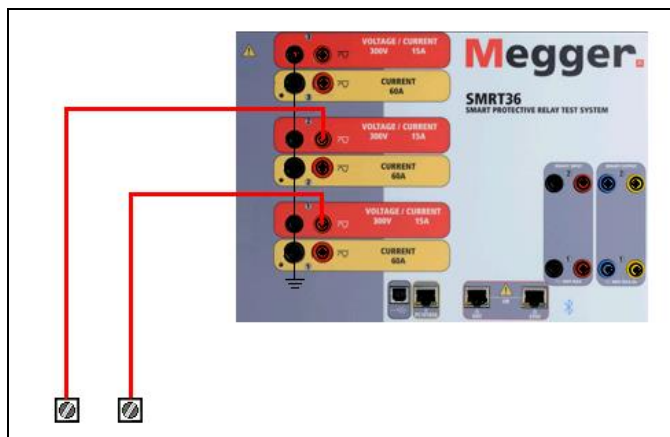

Figure 29 Series of Voltage Channels with SMRT36 Grounded Common Returns

3.4.2 3Ø, 3-Wire, Open-Delta and T-Connection

3.4.2.1 Balanced Open Delta

Two methods of obtaining a three-phase, three-wire voltage source are available. The Open-Delta configuration is the easier to use when a balanced three-phase source is required because the amplitude and phase relationship can be set directly. No calculations are necessary.

When using the Open-Delta configuration, it is suggested to use voltage channel #1, designated V_1 , and voltage channel #2, designated V_2 , while the COMMON binding post is designated V_g . With this arrangement, the magnitude and phase angle of the potentials can be easily calculated and set. For the balanced three-phase condition V_{1-g} and V_{2-g} are equal in magnitude and separated by an angle of 60° . This is done by setting the V_1 and V_2 potentials equal in magnitude, setting 0° on V_1 and 300° (60 degrees leading assuming that the default phase rotation is set to 360 Lag) on V_2 , see the following figures.

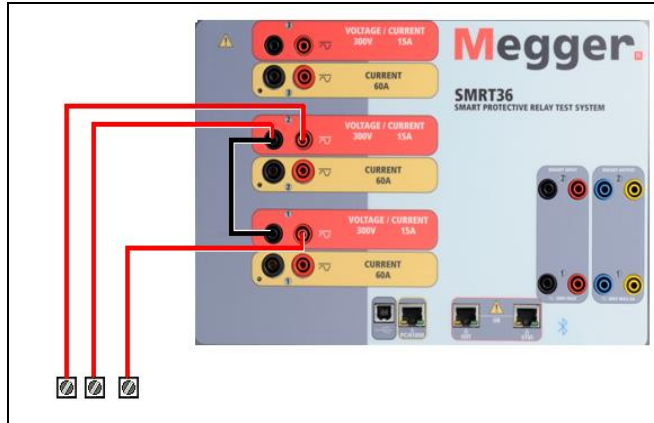
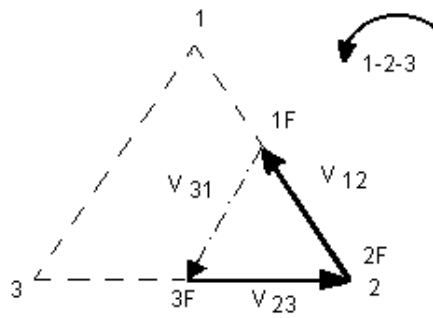

Figure 30 Three Phase Open Delta Connections

When using the Open-Delta Configuration to set up a phase-to-phase fault, calculations' using the Law of Cosines is required to calculate amplitude and phase relationships. (See discussion under T-Connection for simulating unbalanced, phase-to-phase faults without need for calculations.)



Balanced 3θ - Open Delta Connection

If V_f equals the desired test potential, then:

- Set $V_1 = V_f \angle 0^\circ$
- Set $V_2 = V_f \angle 300^\circ$ (360 Lag configuration)

3.4.2.1.1 Unbalanced Open Delta

When setting up an Unbalanced Open-Delta configuration, the desired phase-to-phase fault voltage, V_{1f} is set using voltage channel #1 with its phase angle set to 0° . Phase-to-phase voltage V_{2f} and its phase angle relationship for voltage channel #2, must be calculated using the Law of Cosines; where for any triangle the following formula applies:

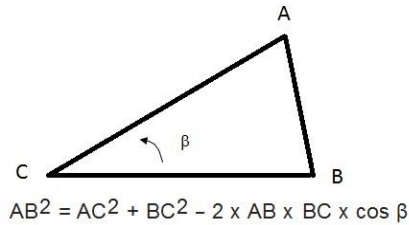

The next figure shows the phase relationships between voltages and an example of the necessary calculation. For convenience the amplitude and the phase angle settings for the typical V_f fault magnitudes are tabulated.

From the Law of Cosines

$$\theta = \arccos\left(\frac{V_{12}}{2 * V_{23}}\right)$$

$$V_{23}^2 = \left(\frac{V_{12}}{2}\right)^2 + \left(\frac{\sqrt{3}}{2} * 120\right)^2$$

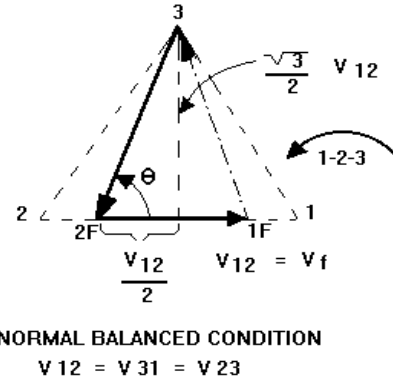

Figure 31 Open-Delta Unbalanced phase-to-phase Fault Voltages

Settings for Typical Phase-to-Phase Fault Voltages

$$V_{12} = V_f$$

V_{12}	1	5	10	15	20	25	30	35	40	45	50	55	60	65	70
V_{23}	104	104	104	104	104	105	105	105	106	106	106	108	108	109	110
At θ° Lag	270	271	273	274	275	277	278	280	281	282	284	285	286	287	289

3.4.2.2 T Connection

The second method of obtaining a three-phase, three-wire voltage source is the so-called T-Connection. The method, shown in the following figure, is easier to use when obtaining an unbalanced, phase-to-phase fault simulation since it eliminates calculations. To reduce confusion when using the T-Connection, the voltage output #1 is designated V_a and its phase angle set at 0° , voltage output #2 is designated V_b and its phase angle set for 180° , and voltage output #3 is designated V_c and its phase angle is set for 270° . Any combination of balanced three phase faults or unbalanced phase-to-phase fault conditions can be easily simulated. The following figure indicates these phase relationships.

!NOTE: This method should not be used for very low fault voltages, or used on solid state relays that may be sensitive to this type of connection (i.e. 5 volts or less, or for testing ABB or Westinghouse type SKD relays).

$$V_f = \text{Desired Fault Voltage}$$

$$V_a = \frac{1}{2}V_f \angle 0^\circ$$

$$V_b = \frac{1}{2}V_f \angle 180^\circ$$

$$V_c = \frac{\sqrt{3}}{2} 120 \text{ or } V_c = 104V \angle 270^\circ$$

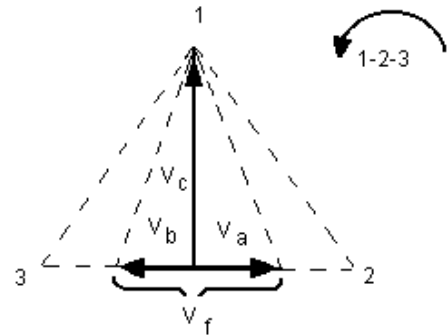

Balanced or Unbalanced Fault T-Connection

3.4.3 3Ø, 4-Wire, Y-Connection

A three-phase, four-wire potential system can be provided using three output modules. The vector relationships are referenced below. This Y-Connection has the advantage of being able to supply a higher line-to-line voltage ($1.73 \times$ phase-to-neutral voltage). It is ideally suited for simulating phase-to-ground faults. Voltage channel #1 is designated as V_a with its phase relationship set for 0° . Voltage channel #2 is then designated as V_b and phase angle set for 120° . Finally, voltage channel #3 is designated V_c and phase angle set for 240° (for a 1-2-3 counter clockwise rotation). V_a , V_b and V_c are connected to the voltage potential binding posts on the respective test sets.

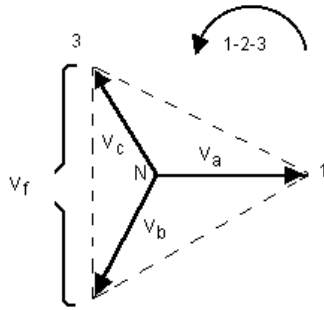

Balanced 3 ϕ , 4 Wire Y-Connection

$$V_f = \text{Desired Fault Voltage}$$

$$V_a = \frac{\sqrt{3}}{3} V_f \angle 0^\circ$$

$$V_b = \frac{\sqrt{3}}{3} V_f \angle 120^\circ$$

$$V_c = \frac{\sqrt{3}}{3} V_f \angle 240^\circ$$

ⓘ Note: If an **F** or **C** appears in the 5th digit of the SMRT style identification number (i.e. 30P1**F**0A0S1) the voltage returns are floating (isolated from each other and ground). Those units with a style number **G** or **E** the voltage returns are common together internally and connected to earth ground.

If using the sleeved multi-lead voltage test leads (part number 2001-395), all of the black return leads are interconnected together inside the sleeve so they will all share the return together. Therefore, only one return lead is provided on the relay connection side of the sleeved leads (similar to the connections in the following figure).

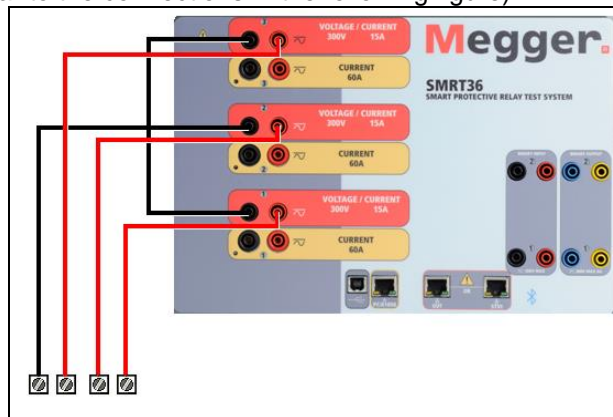

Figure 30 SMRT36 with Floating Returns, Three Phase Four Wire Test Connections

ⓘ For the earth grounded common return (G) units, there is an internal common ground between the voltage and current channel return terminals. Therefore, only one return lead is

required for the voltage channels. If using separate individual test leads, for the floating common units the user must connect the associated voltage channels black common returns together as shown above.

3.5 Testing Relays with the STVI Manual Test Screen

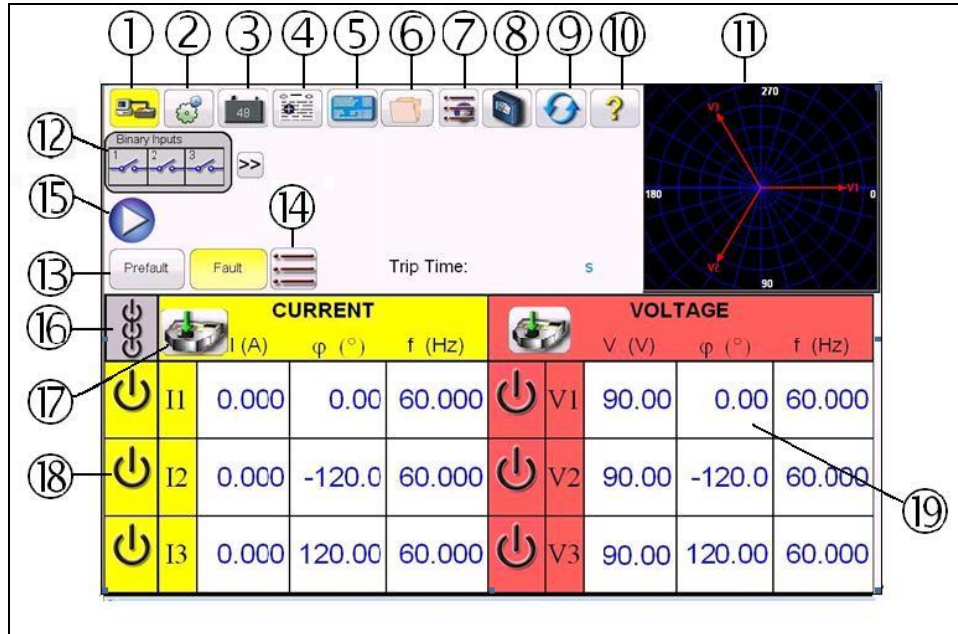

Figure 32 Manual Test Screen

The following tests are examples of how to use the STVI Manual Test Screen for general test applications.

3.5.1 Simple Manual Pickup or Dropout Test

1. Select the channel value(s) to be ramped by pressing the appropriate magnitude window(s) (19). Using the numeric keypad as shown in Figure 12, enter the starting value.
2. Connect the appropriate output terminal(s) for the selected channel(s) to be ramped.
3. Connect the desired Binary Input terminal to sense the relay contacts closing or opening. Select the Binary Input (12) and set the appropriate sensing Continuity or Voltage modes (see Figure 18A).
4. Press the Output Selector Adjustment icon (17), and enter the increment, channel number(s), and whether Amplitude, Phase and Frequency. Note that the selected channel(s) should have a highlighted border around the magnitude window(s).
5. Select the output(s) to be turned on by pressing the ON/OFF icon button (18) for the selected channel(s). Upon pressing the ON/OFF button the center will turn green indicating that the channel has been selected to turn on. Turn the selected output(s) on by pressing All ON/OFF button (16). When the channel(s) turn on the channel window(s) turns green. Using either the Control Knob on the STVI, or the PC up and

down arrows, manually ramp the output(s) until the relay contacts either picks up or drops out, depending on the start value entered in Step 1.

6. Turn the output(s) off by pressing the ON/OFF icon button(s), or press the ALL ON/OFF icon button. By not pressing the ALL ON/OFF button the channel(s) can be turned back on by pressing the channel ON/OFF button again. This provides the ability to toggle outputs on and off in order to observe contact movement at the pickup threshold.
7. Press the Add To Report button (4) if you would like to document this test in your report.

3.5.2 Simple Manual Timing Test

1. Press the Prefault button (13), and set the desired Prefault duration in seconds in the window provided (14).
2. Select the prefault channel(s) to be turned on by pressing the ON/OFF icon button(s) (18). Set the Prefault value(s) by pressing the appropriate magnitude window(s) (19), and using the numeric keypad as shown in Figure 12, enter the Prefault value(s).
3. Connect the appropriate output terminal(s) for the selected channel(s) to be used.
4. Connect the desired Binary Input terminal to sense the relay trip contacts.
5. Press the selected Binary Input (12), note Binary Input #1 is already set to **Use as Trip (enabled)**. Set for the appropriate sensing Normally Open, Normally Closed, Voltage Applied, or Voltage Removed. If the Binary Input selected is set to monitor mode, Use as Trip (disabled), press or click on the button to change it to **Use as Trip (enabled)**, see Figure 18B, and select Input Type and Input Action as desired. If it is desired to turn the outputs off when the relay trips press the Auto Off (disabled) button and select the desired channels to turn off.
6. Press the Fault button, and set the desired fault value(s) by pressing the appropriate magnitude window(s) (19), and using the numeric keypad.
7. Press the Prefault button returning to the prefault settings. Turn the selected channels on by pressing the ALL ON/OFF (16). The prefault outputs should now be on. Press the Blue Play button (15). The Prefault countdown timer will start running. The outputs will change from prefault to fault value(s) and the timer will start running. When the relay trips, the Timer will stop indicating the trip time of the relay under test. Once the test has completed all outputs will be turned off if the auto off was enabled. If Auto Off was not enabled the user can input a Maximum Test Time or a Post Fault Time setting, see 3.1.14 Maximum Test Time/Prefault Time/Post Fault Time Settings button, and the outputs will automatically turn off as desired.



- To save the test result, press the Add to Report button (4). The results have now been added to the report and the report is shown. Note that the values are not actually saved to file until you press the File Folder icon and save them as previously defined. The user can now enter appropriate information relative to the test in the Test Report header.

 **Megger.**
 www.megger.com

SUBSTATION South 40 POSITION _____ PAGE _____
 EQPT. LOCATION Bay1 DATE 7/25/2012
 ASSET ID PR99123 JOB # _____
 TEST EQUIPMENT USED SMRT36P-201207070101 TESTED BY W. E. Fox
Counter Clockwise Rotation 0-360 Lag

NAMEPLATE DATA

MANUFACTURER ACME MODEL A1 SERIAL NUMBER 2802B1
 DEVICES OPERATED _____ CT RATIO 600 : 5 A PT RATIO _____ kV : _____ V
 INSTRUCTION BOOKLET _____

   **Prefault/Fault Test**

Prefault Time (s)	Operation Time	Measured (s)	Minimum Value (s)	Maximum Value (s)	Pass / Fail
0.000		9.476	9.400	9.500	Pass

Channel	Phase	Prefault			Fault		
		Amplitude	Phase Angle	Frequency	Amplitude	Phase Angle	Frequency
Current	L1	0.00 A	0.00 °	60.00 Hz	20.00 A	0.00 °	60.00 Hz

Figure 33 Example PowerDB Report

If using the STVI, use the **Control Knob** to scroll up and down to view all results. Note that there is a space in the upper right corner for company logos to provide a finished and professional look (see Configuration Screen). Also note the Options  button just above the recorded results. Pressing this button the user will be presented with a number of possible choices for the recorded results.

Up
 Down
 Delete
 Retest
 Hide Comments
 Hide Deficiencies
 Close Report
 Cancel

Figure 34 Report Options Screen

The results can be moved up or down to change the order of the results presentation. The result can be deleted, or a retest performed by pushing the blue play button. In addition, the

user can add or hide Comments or Deficiencies. Press either Close report to return to the test screen or press Cancel to return to the report. To exit the report, press the Check button in the top left corner or select the Options button followed by the 'Close Report' button.

3.5.3 Using Auto Ramp / Pulse Ramp / Pulse Ramp Binary Search

The Auto Ramp feature of the STVI software may be used to automatically determine pickup or dropout of various types of relays. Press the Test List button  to get access to the Auto Ramp screen. The user will be presented with two selections I or V (current or voltage channel), then select ramp parameters. Once a channel is selected to ramp the user must then choose which type of ramp (there are three to choose from) or select the Ramp Wizard. The Ramp Wizard automatically sets up the appropriate ramp for different types of applications (see Ramp Wizard for more information).

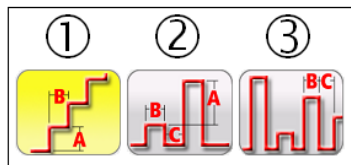

Figure 35 Ramp and Search Tool Bar

3.5.3.1 Step Ramp Example

The first selection ① is the Step Ramp and will ramp the output by applying a value and then waiting a specific amount of time before incrementing it. Depending on what is being ramped the user must define the Start and Stop values of the value being ramped. For example, to automatically ramp output current the user will, input Start and Stop Amplitudes, an Increment (A), and a Delay time in Cycles or Seconds (B). Note: to change from Cycles to Seconds click or touch the word Cycles or Seconds. See the following figure.

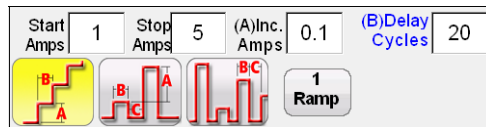

Figure 36 Step Ramp Setting Example

In the above example, 1 Amp was set to Start ramping, with the Stop value at 5 Amps (with the expectation that the relay will pick up before reaching 5 Amps), with an Increment of 0.1 Amps (A) and a Delay (B) time of 20 Cycles between each increment. To start the auto ramp push the blue Play button.

3.5.3.2 Pulse Ramp Example

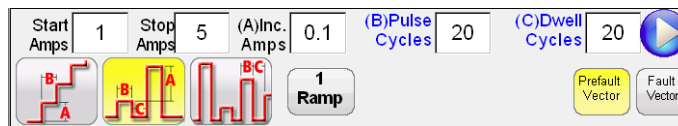

Figure 37 Pulse Ramp Setting Example

The second selection ② is for Pulse Ramp and will ramp the output but will also return to the prefault condition between each increment. The first step is to set the Prefault Vector(s)

followed by setting the Start, Stop, and Increment values for the Pulse Ramp. Instead of Delay time the user sets the Pulse Cycles/Seconds time, which is the time that the incremented value will be applied before going back to the prefaul vector state. The output will then stay at the prefaul values for the Dwell Cycles/Seconds time before progressing to the next increment level until the relay operates. Press or click on the '1 Ramp' button. The user can select a 2nd, 3rd and 4th ramp. This allows the user to select the number of cascaded ramps to be performed. A common use for 2 ramps would be to set the increment level in large steps and then when the relay picks up reduce the output by a percentage of the pickup value. Ramping can then start from that point but at smaller increments until the relay picks up again, thus providing a finer resolution on the actual pickup point. This feature is most used when doing instantaneous pickup tests. The output current, or voltage, can be incremented in large steps getting to the pickup point quickly. This reduces the test time, heating of the relay under test, and provides a very accurate test result. This feature is also used when testing multi zone distance relays using three phase voltage and currents. Set the Pulse Cycles/Seconds duration just long enough for the intended zone to operate. If you are not sure exactly where the pickup value of the relay is you can use the Pulse Ramp Binary Search ③ feature.

3.5.3.3 Pulse Ramp Binary Search Example

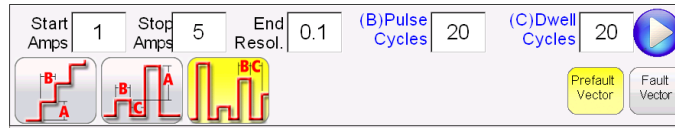

Figure 38 Pulse Ramp Binary Search Setting Example

The third selection ③ on the tool bar is Pulse Ramp Binary Search. The Pulse Ramp Binary Search is used to quickly determine the pickup value of a relay with a questionable or unknown set point or operating characteristic. More importantly, this feature is excellent for testing relays which require a prefaul condition prior to sensing a faul condition. The setting values are almost the same as the Pulse Ramp. However, instead of Increment value, the user defines the End Resolution of the final search increment. On execution the control will incrementally search for the relay pickup starting with Prefault Value(s). The first output will be the Prefault setting(s), then pulsing to the Faul value(s). If an operation by the relay occurs within the Pulse Time, the Faul value(s) output will automatically increment down by 50% of the difference between the last operate and no-operate point. Like Pulse Ramp, the output toggles back and forth between the Prefault and the next Faul value(s). The bi-directional pickup and non-pickup operation keeps dividing back and forth very quickly until the End Resolution is reached. Once the end resolution is reached the final pickup value(s) will be displayed. Where Prefault values are not required a simpler Binary Search could be used.

3.5.4 Using Ramp Wizard

Pressing the Ramp Wizard button presents the user with a selection of three different typical relay tests, and a Custom Ramp. A description of the selections follows.



Figure 39 Ramp Wizard Relay Type Selection Menu

3.5.4.1 EM (Electromechanical) Current Pickup

Pressing the EM Current Ramp button will present the user with the following test screen.

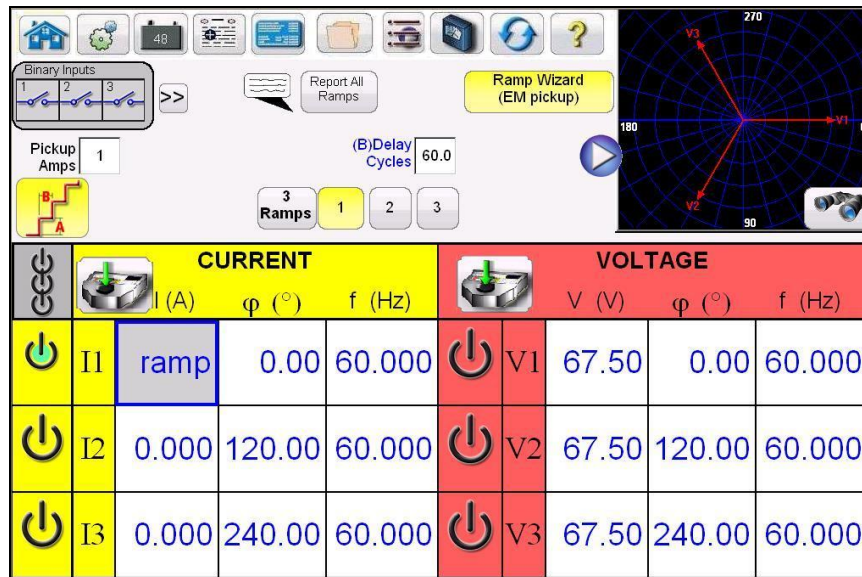



Figure 40 EM Ramp Wizard

EM Current Pickup – This selection provides the user the appropriate type of ramp, and defaults necessary to do a pickup test on an electromechanical overcurrent relay. The wizard will default to three ramps. The basic operation of the test is that the test set will apply twice the **Pickup Amps** entered by the user and wait for the contacts to close. The test current will be dropped by a percentage (labeled the **Start %**) from the twice pickup value applied to the relay, and start ramping down in **Increment Amps**, set as a negative value like -0.05, using a **Delay Cycles/Seconds** entered by the user. The **Start %** value needs to be a percentage of initial test current, so that the contacts will still be closed, but the current will not have to ramp down very far to get the contacts to open. When the contacts open, the current will then reverse and start ramping back up at a different increment until the relay trip contacts close again. The **Start %** point for the ramp back up is a % of where the contacts just opened. The user can set it to 100% thus the ramp back up will start at the same current value where the contacts just opened. The current will ramp back up at the **Increment Amps** setting for Ramp 3, using the same **Delay Cycles/Seconds** set in Ramp 1. Use a smaller increment so that the resolution of the pickup will be much higher. At this point the Pickup value has been determined. There are two **Stop Amps** values that also need to be entered. The first **Stop Amps** associated with Ramp 2 is the lowest current value that the unit will ramp down to looking for the contacts to open. If they have not opened by this point, stop the test something is wrong with the relay. The second Stop Amps value is associated with Ramp 3. This is the maximum current that the unit will ramp up to. If the relay has not operated by this value the test will stop. Normally this value is set to a value 10% higher than the expected

pickup value. For Reporting purposes the STVI will capture the pickup value and enter it into the report. For even more comprehensive results the user can press or click on the Report All Ramps button and the STVI will record where the contacts first closed, dropped on, and the final close for pickup. Press or click on the Preview  button in the Vector Display and a graphical display will show how the test values will be applied.

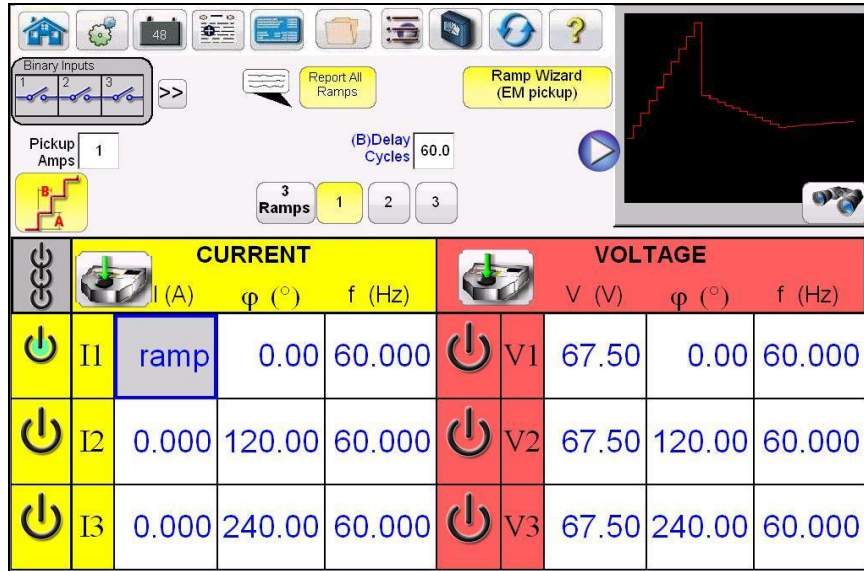

Figure 41 EM Ramp Preview Screen

3.5.4.1 Instantaneous Pickup

Pressing the Instantaneous Pickup button will present the user with the following test screen.

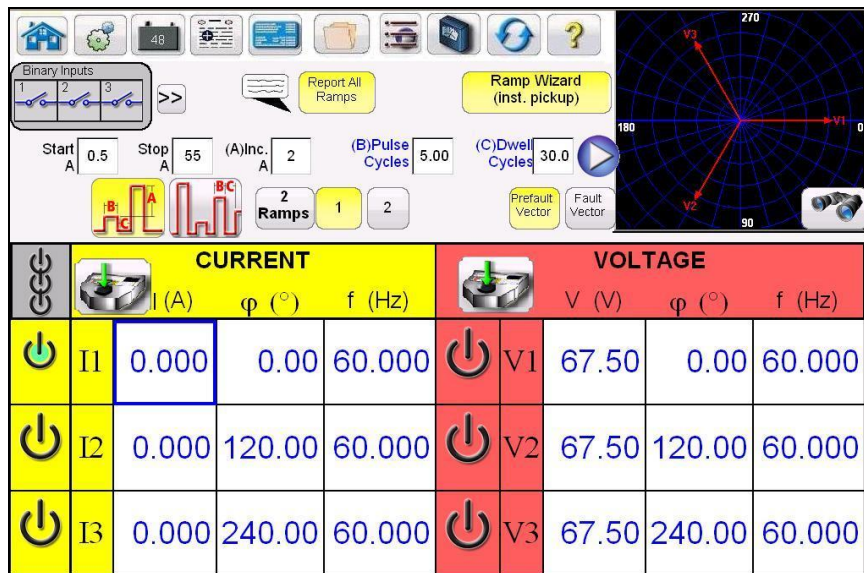

Figure 42 Instantaneous Pickup Wizard

Instantaneous Pickup – This selection provides the user the appropriate type of ramp, and defaults necessary to do a pickup test on an electromechanical instantaneous overcurrent type relay. The wizard will provide two ramps. The user may select from two different styles

of ramp (Pulse Ramp and Pulse Ramp Binary Search). See descriptions above for these ramp styles.

3.5.4.1 Current Target & Seal In

Pressing the Current Target & Seal In button will present the user with the following test screen.

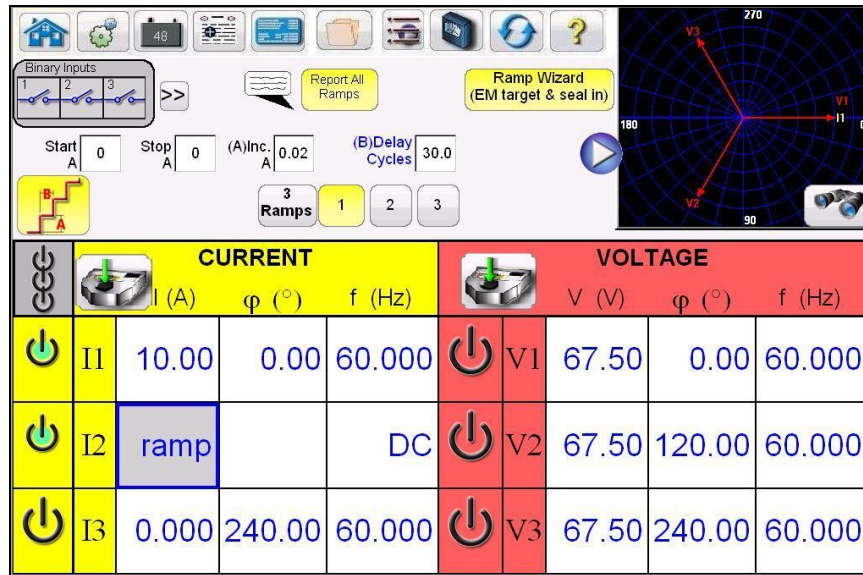





Figure 43 Current Target & Seal Wizard



Current Target & Seal In – This selection provides the user the appropriate outputs and type of ramps necessary to do a pickup and dropout test on an electromechanical overcurrent DC Target and Seal In relay. The wizard will automatically pick two current channels. Channel #1 will provide the AC current necessary to cause the EM trip contacts to close. Current channel #2 will provide the DC current (note the Frequency is set to DC) for the DC target element. For the Step Ramp enter the Start, and Stop values based upon the target element tap setting (typically 0.2, or 2 A DC). Start at 0.15 Amps for the 0.2 Amp tap setting relay. Set the Delay time long enough so that the user will have time to press the SIM button when the contacts close and press again when the contacts open. Application Note: It is difficult to monitor the seal in contacts, therefore, it is up to the user to observe the contacts and press the SIM button when the seal in contacts close or open. Also note that Ramp 2 ramps the current down with a default setting of -0.02 amps. If the tap setting is 2 Amps, it is recommended that the user change the increment to -0.05 amps.

3.5.5 Ramping Battery Simulator Output



1. On the STVI display screen press the  Manual Ramp Options button. In Channel Increment Selection Screen press or click on the Battery button. Select the desired increment level of the Battery Simulator, 1 or 5 volt increments. Press on the green check button.
2. Upon returning to the main test screen, note the Battery Simulator will be set for the value setting in the configuration screen. If another starting value is desired, go to the configuration  screen and enter the starting value in the window provided, and

press the green check button. For manual ramping press the  All ON/OFF button, note button turns green.

- Press the battery  button and note that it changes to red indicating that the battery output is on, and it will have a yellow arrow through the box  with the dc starting value to be ramped. Use the control knob (pc version use the cursor up down arrows or mouse control wheel) to vary the dc voltage output (clock wise increases the output). One click will equal the increment setting. To turn the battery simulator off, press the battery button. Note: If you have completed the test press the All ON/OFF button. Once the All ON/OFF button is off, the battery simulator can be turned on and off by pressing the battery button, but it cannot be varied.

3.5.6 Timing Test

Press the Test List button  to get access to the Timing Test icons. Pressing the appropriate timing icon (Current, Voltage, or Frequency) from the menu takes the user to the **Timing Test Screen**. Timing tests are provided for a wide variety of protective relays, including Overcurrent, Voltage, and Frequency relays. This includes time curves and time curve algorithms for hundreds of different specific relays selectable by manufacturer, model number, and curve shape (inverse, very inverse, definite time etc.). In addition it also includes ANSI, IEEE and IEC Standard time curve algorithms.

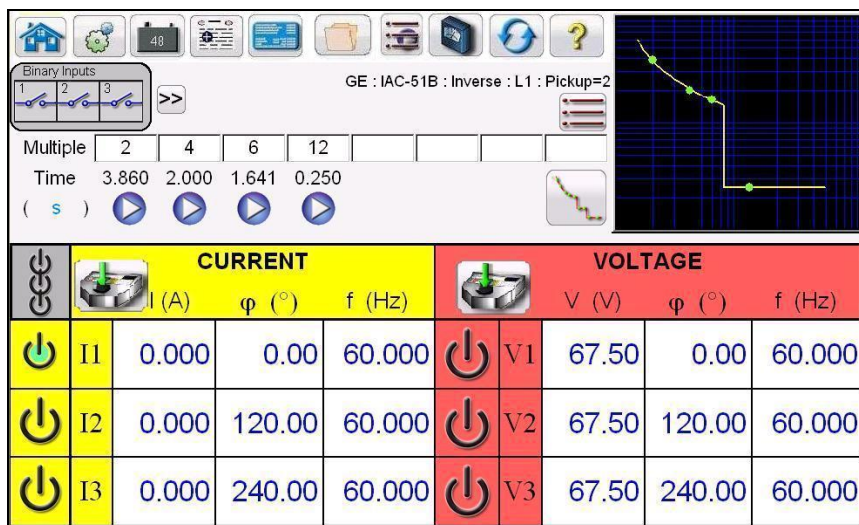



Figure 44 Initial Timing Test Screen

3.5.6.1 Timing Test Setup

Press the Setup and Settings  button. The user will be presented with the **Timing Test Setup** Screen where the user can select the type of relay to be tested.

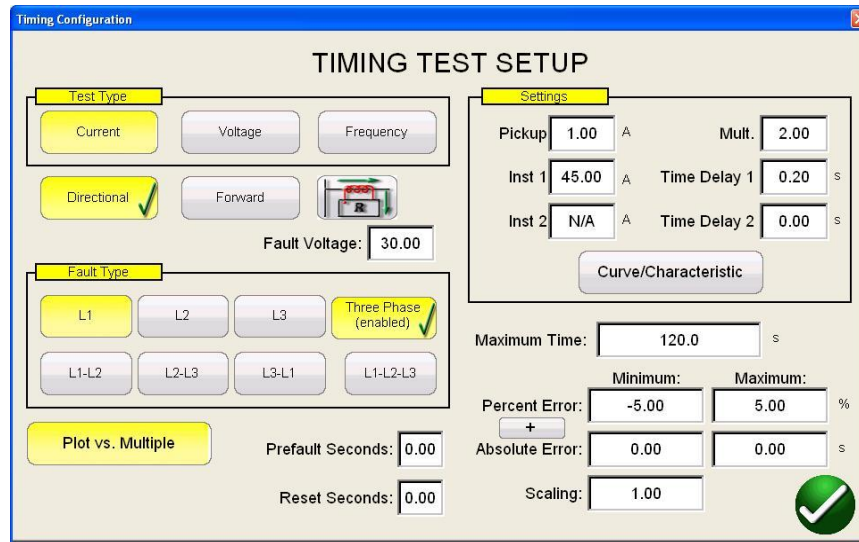

Figure 45 Directional Overcurrent Timing Test Setup Screen

Test Type – Select a **Current**, **Voltage** or **Frequency** relay.

Directional- For testing directional overcurrent relays which require a voltage be applied to polarize and close the directional element, click on or press the Directional button to provide the directional settings (see Figure 45). The user will need to enter the desired fault voltage if required, and set the CT polarity (current into or out of polarity) by clicking on the graphic. This will automatically set the phase angle relationship of either 0 or 180 degrees for the output current relative to the fault voltage. The user can also click on the Forward/Reverse button to specify the direction of the fault , which will also set the phase angle relationship to 0 or 180 degrees.

Fault Type – Select which phase is to be tested. If you are testing a single phase relay, click on the **Three Phase** button to disable the phase to phase and three phase test buttons. For three phase relays, the user can connect all three phases and individually test each phase one at a time by selecting the individual phase from this setup screen. The tests will be recorded for each phase as they are completed. Selecting three phase (**ABC**, **L1-L2-L3**, etc) will apply three phase current to the relay. Selecting phase to phase (**A-B**, **L1-L2**, etc) will apply phase to phase values.

Settings – Enter the setting values of the relay to be tested.

Pickup equals **Tap** value for most electromechanical relays.

TDM stands for Timer Dial Multiplier, which is the same as the **Time Dial** for most electromechanical relays.

Inst 1 is the instantaneous trip value.

Time Delay 1 is the maximum operating time, or the programmed delay time, of the instantaneous trip 1. The same for Inst2 should the relay have 2 instantaneous elements.

Maximum Time is the maximum time allowed for the relay to operate. If the relay has not operated by this setting value, the test will automatically abort.

Prefault Seconds is the time that a prefault state will be applied to the relay before applying the fault value (when testing voltage and frequency induction disk relays, set the Prefault seconds long enough for the disk to move and stabilize prior to applying the fault).

Reset Seconds is the programmed reset time or the time required for the induction disk relay to reset. If this value is non-zero, pressing the first play button will not only test the first point, but will test all subsequent defined points with a delay of Reset Seconds between tests.

Percent Error and **+ Absolute Error** allow the user to define what the maximum and minimum allowable error that will be used for comparison to the theoretical in the test report for pass and fail criteria. **Absolute Error** is typical when testing frequency relays, where the operating time is a total of % of setting \pm Cycles or Seconds. The value entered is in seconds. If the relay has a \pm 3 Cycles of absolute error, the user will need to convert the time into seconds and enter that value. **Application note:** For some frequency relays the “ \pm Cycles” is based upon the **fault frequency** applied to the relay, not the system frequency. The user must convert the fault frequency Cycles to seconds to enter the absolute error value.

3.5.6.2 Relay Manufacturer and Curve Selection

Pressing the **Curve / Characteristic** button for **Overcurrent** will provide the following menu selection screen.

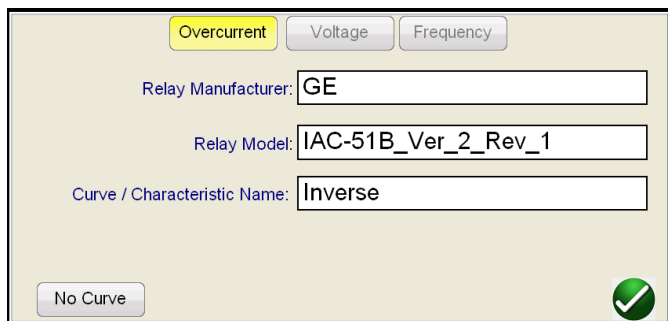

Figure 46 Overcurrent Relay Manufacturer and Relay Curve Selection

Relay Manufacturer – Touch or click on the window and the user will be presented with a pull-down list of various overcurrent relay manufacturers, or select ANSI, BS142, IEC or IEEE time curve algorithms.

Relay Model – Touch or click in the window and the user will be presented with a pull-down list of various models of relays from the Manufacturer for which there are time curves programmed into the STVI software. If a particular relay is not present in the listing, it means that the manufacturers' time curve is not available, or it may be a new relay which has not been programmed into the STVI software yet. Check the Megger website for a possible STVI upgrade download. New STVI upgrades are available from time to time, which may include

new time curves or time curve algorithms. Check with your local Megger sales office or representative for more information. If a specific curve is not available, consider using one of the IEC or IEEE Time Curve algorithms. New microprocessor based relays closely follow the IEC and IEEE time curve algorithms, and thus these standard curves may be used for your test requirements.

Curve / Characteristic Name – Depending on the model relay selected the curve type may be automatically selected and displayed. In the case of the ANSI, BS142, IEC or IEEE time curves a curve type must be selected in this window. If there is No Curve for the relay test points may be defined by checking the No Curve button.

No Curve – Timing Configuration Window – By clicking on the No Curve button the user will see a Timing Configuration table where the appropriate Test Multiple can be entered along with the appropriate trip time in seconds, see the following example.

#	Multiple	EXPECTED VALUE
1	2	7.2
2	3	3.5
3	4	3.1
4	5	2.8
5		

Figure 47 No Curve Timing Configuration Setting Screen

Up to 5 test points may be defined. When tests are conducted the cross hatch indicating the min and max acceptance limits and actual test points might appear something like the following.

CURRENT				VOLTAGE			
	I (A)	ϕ ($^{\circ}$)	f (Hz)	V (V)	ϕ ($^{\circ}$)	f (Hz)	
I1	0.000	0.00	60.000	V1	67.50	0.00	60.000
I2	0.000	120.00	60.000	V2	67.50	120.00	60.000
I3	0.000	240.00	60.000	V3	67.50	240.00	60.000

Figure 48 Sample Test Result for No Curve Trip Settings

Time Dial / Time Multiplier- Enter the Time Dial or Time Multiplier setting from the relay under test. This value will be used when calculating the theoretical operating time of the relay in the Timing Test Screen.

Press the green check button to return to the Setup Screen. Return to the test screen by pressing the green check button. Upon returning to the Timing Test Screen, the selected relay time curve will now appear in the upper right display.

3.5.7 Timing Test – Overcurrent Relays

Tests should be conducted in accordance with the manufacturers relay specifications. Following the Timing Test setup described in 3.5.6, returning to the Timing Test Screen the user will see something similar to the following figure.

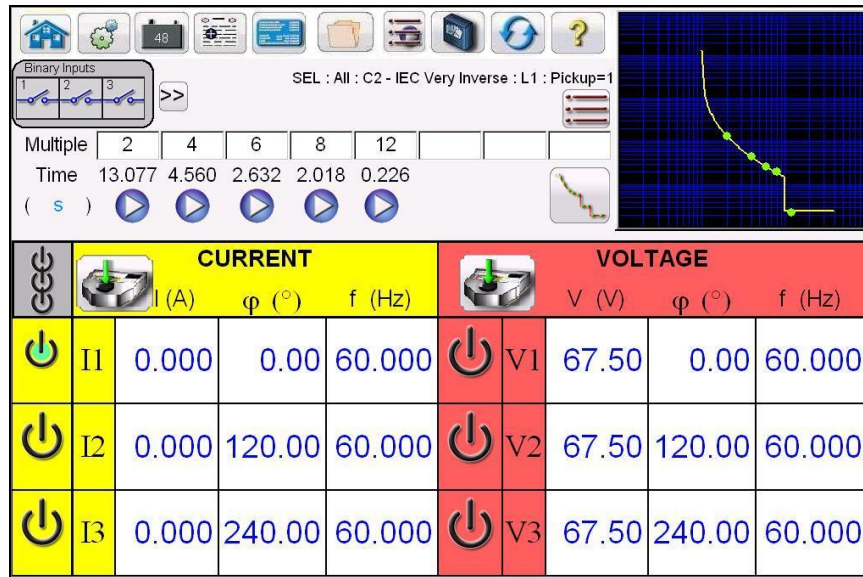

Figure 49 Example Timing Test Results – SEL C2 IEC Very Inverse with Instantaneous

Multiple – This is the multiple of the Pickup or Tap value that will be applied to the relay under test. The user is free to change the values to any desired multiple(s). Up to 8 test points maybe defined.

Timing Test

1. Press the Timing icon, and select the desired overcurrent relay in the Setup Screen. Enter the settings as described above in section 3.5.6.
2. If required, set the Prefault value(s) by pressing the appropriate magnitude window(s), and using the numeric keypad, enter the Prefault value(s). Connect the appropriate output terminal(s) for the selected channel(s) to be used. Select the Prefault channel(s) by pressing the ON/OFF icon button(s), and turn the outputs ON by pressing the All ON/OFF button.
3. Connect the desired Binary Input terminal to sense the relay trip contacts. Press the selected Binary Input. If the Binary Input is already set to **Use as Trip (enabled)**,

select for the appropriate sensing Normally Open, Normally Closed, Voltage Applied, or Voltage Removed. If the Binary Input is set to monitor mode, Use as Trip (disabled), press or click on the button to change it to **Use as Trip (enabled)**, see Figure 18B, and select Input Type and Input Action as desired. If it is desired to turn the outputs off when the relay trips press the Auto Off (disabled to enabled) button and select the desired channels to turn off.

4. Press the Play button under the desired test Multiple. The Fault value(s) will be applied. When the relay trips, the Timer will stop indicating the trip time directly under the test Multiple. If the Reset Time is not zero, pressing the first play button will execute each of the test multiples in order with the Reset Time between each test. Selecting Test Multiples 2 through 8 will execute only the test multiple selected or set.

To View the test result, press the Add to Reports button. The user can now enter appropriate information relative to the test in the Test Report header.

3.5.8 Timing Test - Voltage Relays

Tests should be conducted in accordance with the manufacturers relay specifications. Following the Timing Test setup described in 3.5.6, returning to the Timing Test Screen the user will see something similar to the following figure.

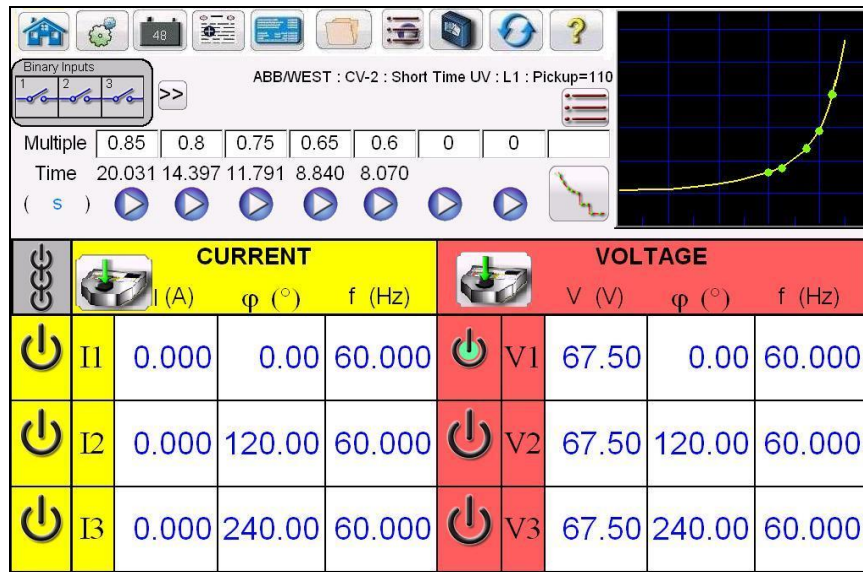

Figure 50 Example Voltage Timing Test – ABB/Westinghouse CV-2 Under Voltage Relay

Note: The STVI will automatically set the output frequency to the frequency set in the Configuration screen. If required change the frequency in the test screen.

Multiple – This is the multiple of the Pickup or Tap value that will be applied to the relay under test. The user is free to change the values to any desired multiple. For Under Voltage

relays the Test Multiple is in percent less of the Pickup or Tap value, i.e. 85%. For Over Voltage relays the Multiple is greater than Tap, i.e. 110%.

Timing Test

1. Press the Timing icon, and select the desired voltage relay in the Setup Screen. Enter the settings as described above in section 3.5.6.
2. For voltage relays set the rated voltage to the relay by pressing the appropriate magnitude window, and using the numeric keypad, enter the value, i.e. 120 Volts. Connect the appropriate output terminal for the selected channel to be used. Select the voltage channel by pressing the ON/OFF icon button, and turn the outputs ON by pressing the All ON/OFF button. With rated voltage now being applied to the relay the trip contacts will open and the relay will be in the normal pre-fault mode.
3. Connect the desired Binary Input terminal to sense the relay trip contacts. Press the selected Binary Input. If the Binary Input is already set to **Use as Trip (enabled)**, select for the appropriate sensing Normally Open, Normally Closed, Voltage Applied, or Voltage Removed. If the Binary Input is set to monitor mode, Use as Trip (disabled), press or click on the button to change it to **Use as Trip (enabled)**, see Figure 18B, and select Input Type and Input Action as desired. If it is desired to turn the outputs off when the relay trips press the Auto Off (disabled) button and select the desired channels to turn off.
4. Press the Play button under the desired test Multiple. The Fault value will be applied. When the relay trips, the Timer will stop indicating the trip time directly under the test Multiple. If the Reset Time is not zero, pressing the first play button will execute each of the test multiples in order with the Reset Time between each test.

To View the test result, press the Add to Reports button. The user can now enter appropriate information relative to the test in the Test Report header.

3.5.9 State Sequence Timing Test – Multi-Shot Reclose Relays



These tests should be conducted in accordance with the manufacturers relay specifications.

Press the Test List button  to get access to the State Sequence Test. Pressing the

 button on the test menu takes the user to the Sequence Timing Test Screen defined in the following screen.

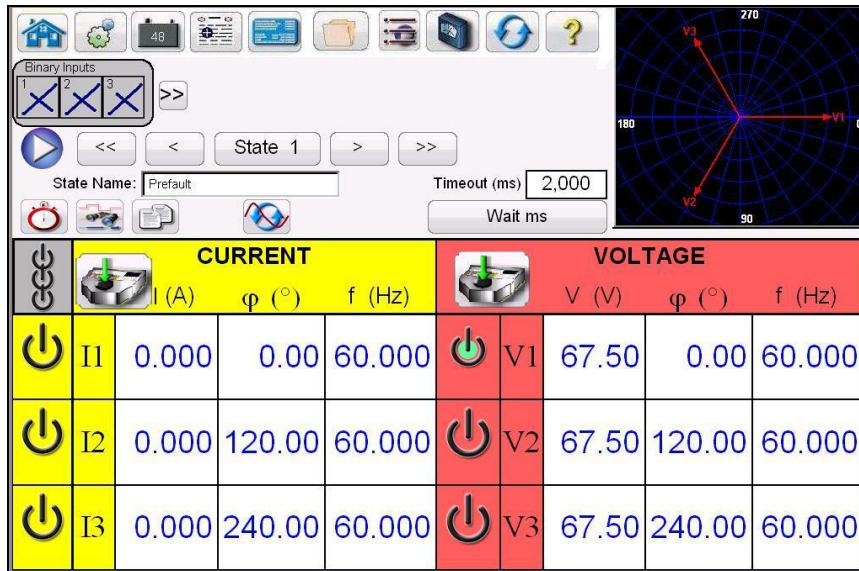



Figure 51 Sequence Test Screen

There are 15 programmable steps available in the Sequence Test Screen. By default, there are 9 states already preconfigured and labeled as *Prefault*, *Trip1*, *Reclose 1*, etc. up to *Lockout* in step 9. It is initially setup for a four shot trip, reclose to lockout scenario. Another test application is a developing fault scenario, or use to perform dynamic end-to-end tests. The user is free to change the labels, or use the default labels. With each state the user may input values of voltage, current, phase angle, frequency and set the binary input sensing for each state. Both single pole and three pole trip can be simulated. There are default values and binary settings for a single phase trip and reclose scenario already programmed in. The user can either use the defaults or change them to suit the test application, as well as extend or shorten the number of states. Press the **Timers** button  to view the **Sequence Timer Configuration** screen and Labels. The user can view and set where each timer starts and stops in association with each trip and reclose operation (see the following figure).

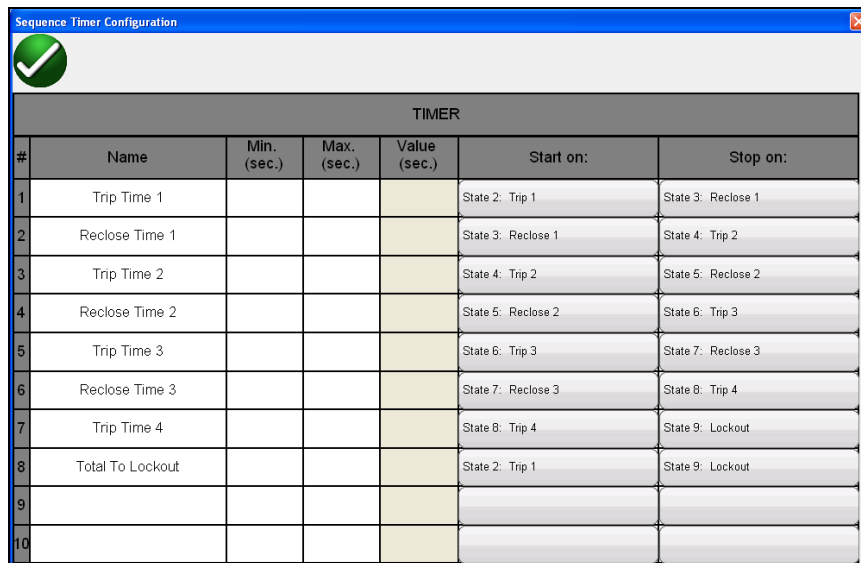

Figure 52 Sequence Timers Settings and Labels Screen

Note that the Total Time to Lockout is also included in the setting and indicates where the total timer starts and stops. This allows for 1, 2, 3, 4 or more shots to lockout including reclose times. To change the Start and Stop conditions, press or click the appropriate windows. Start or Stop can be set using either the change of State, or Post, see the following figure.

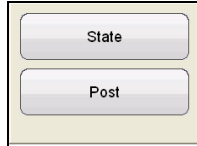

Figure 53 Timer Conditional State Post Selector

Pressing State the user will be presented with the number of States that were previously set by the user. The user can start or stop the timer when the sequencer steps to that State. Pressing Post, the timer will start or stop based upon the change of the defined binary input Post #, see section 3.1.10 for use of the Binary Input Dialog box. If desired, enter the appropriate minimum and maximum trip and reclose times in the spaces provided. At the end of the test, the test results will include the min, max, and Pass/Fail determination for each state.

Return to the Sequence test screen, to set the conditions for each change of state. Press the **Wait Any** button directly under the Timeout window. The user will be presented with several selections to choose from. These are the conditions that the unit will take in order to determine when to change to the next state, or end the sequence, see the following menu selection.



Figure 54 State Sequence Conditional Setting Screen

Wait ms – The unit will wait the milliseconds entered in the window before changing to the next state in the sequence.

Wait Cycles – The unit will wait the Cycles entered in the window before changing to the next state in the sequence.

Wait Any (Continue) – Wait for any of the configured binary inputs to be true and then continue with the sequence. Note that an input can be configured for the Wait Any (OR) and Wait All (AND) conditions by clicking on the binary inputs.

Wait Any (Abort) – The unit will wait for any of the configured binary inputs to be true, and then continue with the sequence. If no binary inputs become true before the **Timeout** setting value, the test will be aborted. Note that the timeout feature is only available for SMRT and MPRT8445 test sets (not available on MPRT 8415/8430 units).

Wait All (Continue) – Wait for all selected binary input conditions to become true, or the Timeout is exceeded before continuing to the next state.

Wait All (Abort) – Wait for all selected binary input conditions to become true, or the Timeout is exceeded before continuing to the next state. If all selected binary inputs have not become true by the **Timeout** setting value, abort the test.

Wait IRIG – The unit will wait the IRIG Time entered in the IRIG window before changing to the next state in the sequence (used for end-to-end tests).

End – If the relay under test makes it to this state, end the test.

To set the Binary Outputs to simulate the 52a and/or 52b contacts press the Binary more  button next to the Binary Inputs to expand the selection window. In the default state you may choose to have Binary Output 1 contact in the closed condition to simulate breaker closed. Click on Binary Output 1 and the binary output setting window will appear. The default setting is Open. Click on the Close Contact Button to simulate breaker closed. Note the Name in the window is defaulted to 1. The user is free to rename it to any value such as 52a. To rename the binary inputs or outputs, press or click in the Name window, and the virtual keyboard will appear. Up to 6 characters will appear in the binary window in the test screen. Press or click on the green check button to return to the test screen.

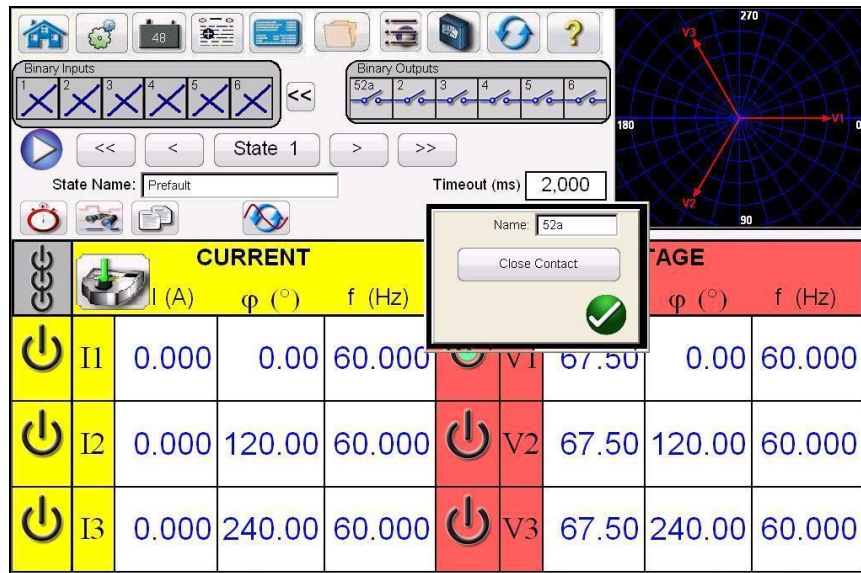

Figure 55 Binary Output Setting Screen

Once all of the Binary Inputs, Outputs, Prefault, Fault and Reclose settings are completed, the user can then press the Preview  button to get a visual representation of the voltage and current outputs, as well as a visual of the binary inputs and outputs for each stage of the simulation. The following figure illustrates an example trip and reclose sequence.



Figure 56 State Sequence “Split View” Preview Screen

There are two views available to the user. One view is called the “Single View” where all the voltages, currents, binary inputs and outputs are overlaid. In the above figure a single phase 4 trip and reclose is shown in the “Split View”, where the voltages, currents, binary inputs and outputs are split up like a fault recording. The red color is the magnitude of Channel 1 (faulted phase) voltage and current outputs. The fat/thin lines represent the binary inputs and outputs per the colors defined in the legend. A “fat” line indicates contacts are closed, and a thin line indicates that the contacts are open. When the fault current is applied, you can see when the trip contacts closed and when the binary output contact opened. When the “breaker” opens you can see the current going to zero. When the breaker closes you see the current being reapplied and then repeat the trip and reclose cycle until lockout. The user can toggle back and forth between the two views by pressing the Switch to Single View/Split View button in the lower right corner of the screen. To exit this screen, press the green check button to return to the State Sequence screen.

To execute the test press the Blue play button. Save and review test results as previously discussed.



Megger.
www.megger.com



SUBSTATION South 40 POSITION _____ PAGE 1
 EQPT. LOCATION _____ DATE 7/26/2012
 ASSET ID 123ABC JOB # _____
 TEST EQUIPMENT USED SMRT36-20121107110110 TESTED BY C. V. Smith
 Counter Clockwise Rotation 0-360 Lag

NAMEPLATE DATA
 MANUFACTURER ACME MODEL RH123 SERIAL NUMBER 983363
 DEVICES OPERATED _____ CT RATIO 600 : 5 A PT RATIO _____ kV : _____ V
 INSTRUCTION BOOKLET _____

Reclosing Test





State Name	Wait		Voltage A	Voltage B	Voltage C	Current A	Current B	Current C	Binary Output
	Mode	Timeout(ms)							
Prefault	Wait ms	2000	67.50 @ 0.0	67.50 @ 120.0	67.50 @ 240.0	1.00 @ 0.0	0.00 @ 120.0	0.00 @ 240.0	1
Trip 1	Wait Any (Abort)	10000	35.00 @ 0.0	67.50 @ 120.0	67.50 @ 240.0	10.00 @ 0.0	10.00 @ 120.0	10.00 @ 240.0	0
Reclose 1	Wait Any (Abort)	10000	67.50 @ 0.0	67.50 @ 120.0	67.50 @ 240.0	0.00 @ 0.0	0.00 @ 120.0	0.00 @ 240.0	1
Trip 2	Wait Any (Abort)	10000	35.00 @ 0.0	67.50 @ 120.0	67.50 @ 240.0	10.00 @ 0.0	10.00 @ 120.0	10.00 @ 240.0	0
Reclose 2	Wait Any (Abort)	10000	67.50 @ 0.0	67.50 @ 120.0	67.50 @ 240.0	0.00 @ 0.0	0.00 @ 120.0	0.00 @ 240.0	1
Trip 3	Wait Any (Abort)	10000	35.00 @ 0.0	67.50 @ 120.0	67.50 @ 240.0	10.00 @ 0.0	10.00 @ 120.0	10.00 @ 240.0	0
Reclose 3	Wait Any (Abort)	10000	67.50 @ 0.0	67.50 @ 120.0	67.50 @ 240.0	0.00 @ 0.0	0.00 @ 120.0	0.00 @ 240.0	1
Trip 4	Wait Any (Abort)	10000	35.00 @ 0.0	67.50 @ 120.0	67.50 @ 240.0	10.00 @ 0.0	10.00 @ 120.0	10.00 @ 240.0	0
Lockout	End	0	67.50 @ 0.0	67.50 @ 120.0	67.50 @ 240.0	0.00 @ 0.0	0.00 @ 120.0	0.00 @ 240.0	0

Timer Name	Time (s)	Minimum Value (s)	Maximum Value (s)	Pass / Fail
Trip Time 1	0.040	0.010	0.055	Pass
Reclose Time 1	0.045	0.030	0.050	Pass
Trip Time 2	0.040	0.010	0.055	Pass
Reclose Time 2	1.500	1.000	2.000	Pass
Trip Time 3	0.160	0.150	0.170	Pass
Reclose Time 3	1.602	1.000	2.000	Pass
Trip Time 4	0.163	0.150	0.170	Pass
Total To Lockout	3.450	2.260	4.500	Pass

Figure 57 Example Sequencer 4 Shot Trip and Reclose

3.6 Testing Impedance Relays with the STVI Click On Fault

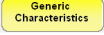
The STVI Impedance Relay Click On Fault (CoF) provides a quick approach to testing an impedance relay.

Press the Test List button  to get access to the STVI Impedance Relay Click On Fault. Then press the  Impedance Relay button. Select from; the Generic Characteristics relay  button, or the Relay Library  Button, or the RIO  Button. Pressing the Generic button will provide a library of generic impedance relay characteristics to choose from. Pressing the Relay Library will provide a library of relay specific characteristics by various manufacturers. Pressing the RIO button multiple characteristics that exist in RIO file formats may also be imported and used in the COF Test Screen.

3.6.1 Common Settings

The following settings are common to both Generic and Relay Specific from the Relay Library.

3.6.1.1 Tolerance Settings

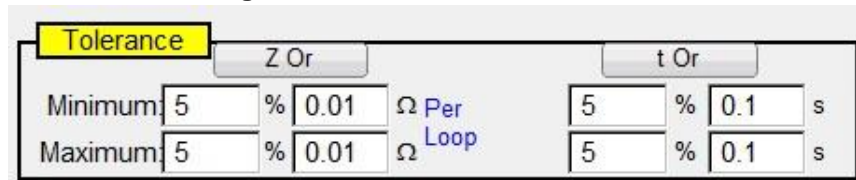
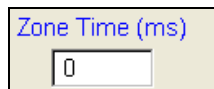

Figure 58 Tolerance Settings Dialog Box

Enter Maximum and Minimum Percentages, or enter the maximum and minimum Ohmic and Time values for Pass / Fail evaluation of the test results. Z = % of Impedance in Ohms, and Time values are in % of Expected Trip Time setting. Press on the **Z Or**, and/or, the **t Or** button, and the buttons will change to read Z Plus and t Plus, which will be a summation of the two values. When performing pickup tests using Pulse Ramp if a time is entered into the Expected Trip Time window the software will record the trip time as well as the pickup value.

Application Note: To save time if the tolerance is the same for all zones, enter the tolerance values once, then press the Copy Tolerance to All Zones button, then press the Paste Tolerance to All Zones.

3.6.1.2 Zone Trip Time Settings



Enter expected trip time for each Zone of operation. Settings are defaulted in milliseconds. To change to Cycles click on the **ms** and it will change to **cy** for Cycles. When conducting reach tests using Pulse Ramp the software will capture the operating time of the pickup and compare to the expected trip time and provide pass/fail indication.

3.6.1.3 DIRECTION / OFF Setting Button

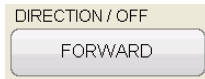

The default setting is in the FORWARD direction. Pressing the button will present the user with four selections, OFF, FORWARD, REVERSE, (and with QUAD, NON-DIRECTIONAL). Selecting REVERSE will flip the operating characteristic over in the reverse direction. For QUAD test applications, selecting the NON-DIRECTIONAL will create dual characteristics for the selected zone, one in the forward and one in the reverse direction.

3.6.1.4 Zones/Fault Selection Box

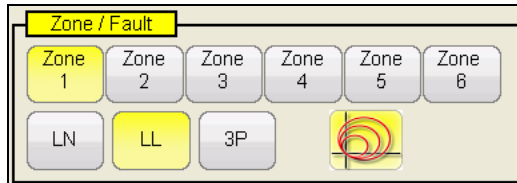

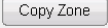

Figure 59 Zone and Fault Type Selection Dialog Box

The user can select which Zone they wish to define, with up to 6 Zones selectable. When more than one Zone is defined; to view multiple zones all in the same graphic window press the  multi-zone display button. When pressing the icon the background color will change and you will see the multiple zones displayed in the impedance plane display. Touch the window again and it will return to single zone display format. The user can define **LL**- Phase to Phase fault, **3P**- 3 Phase Fault, or **LN**- Phase to Ground fault.

Application Note: To save time enter the reach and angle settings once, then use the Copy Zone  button, then select one of the other fault types and press the Paste Zone button and all of the values entered for the previous fault type will be entered for the other fault type. Note this should be limited to only same zone fault types. Selecting **LN** phase to ground will provide an additional button to enter the appropriate Ground Compensation factors, see Ground Compensation Settings.

3.6.1.5 Ground Compensation Settings



In the Generic screen there are three types of compensation factors to choose from depending on the type of impedance characteristic. For MHO and Half MHO, **KN** and **Z0Z1** are available.

Residual compensation factor, KN, is a complex number that is used to express the earth-return impedance, ZN, in terms of the positive-sequence impedance reach setting, Z1. This factor is calculated as:

$$KN = ZN / Z1 = (Z0 - Z1) / (3Z1)$$

Where: Z0 is the zero-sequence impedance polar reach of the zone

Z0Z1 Ratio = the complex ratio of Z0/Z1, also referred to as **K0=Z0/Z1**

For QUAD (quadrilateral) there are three choices: **KN**, **Z0Z1**, and **RE/RL XE/XL**.

RE/RL XE/XL is a pair of scalar factors. These factors affect the resistive reach and reactive reach of some polygon characteristics. They are calculated as follows:

$$RE/RL = (R0/R1 - 1)/3$$

$$XE/XL = (X0/X1 - 1)/3$$

Where:

R1 = real part of Z1

X1 = imaginary part of Z1

R0 = real part of Z0

X0 = imaginary part of Z0

Press the Ground Compensation button and the following settings window will appear.

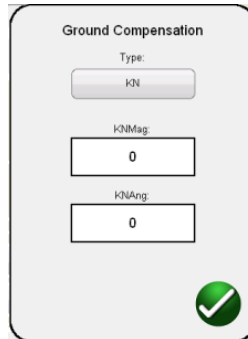
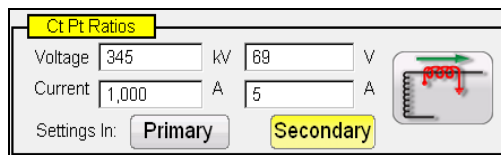

Figure 60 Ground Compensation Settings Dialog Box

The default screen is for KN. To enter Z0Z1 or RE/RL XE/XL values press the Type (KN) button. Where the compensation factors are part of the relay settings (such as the Relay Library AREVA Quadramho) the Compensation button will not be provided, but the values will be calculated based upon the actual relay settings. Enter the magnitude and angle for the appropriate compensation value, and the software will calculate the relay operating characteristic and appropriate test values in the test window.

3.6.1.6 CT PT Ratios



The Primary and Secondary buttons control the scaling in the impedance graph, and are associated with the CT and PT values entered. Enter the appropriate primary and secondary values. Press either the Primary or Secondary buttons and the ohmic scaling will change in the impedance graph. The polarity of the CT can also be set in this window.

3.6.2 Generic Characteristics

Pressing the Generic Characteristics button will provide three options, MHO, Half MHO and QUAD (Quadrilateral).

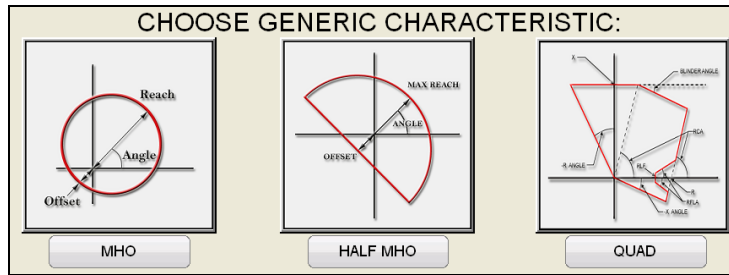

Selection of the MHO will provide the Generic MHO Setting Screen.

3.6.2.1 Generic MHO Setting Screen

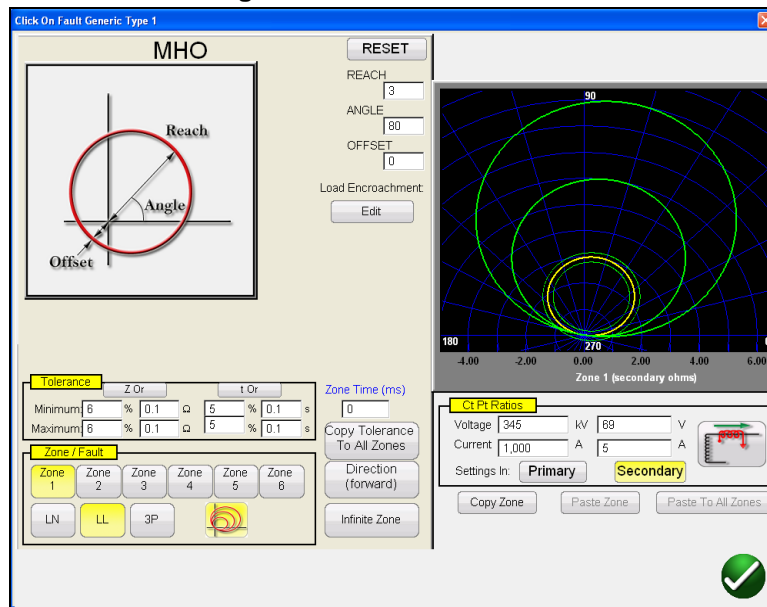

Figure 61 Generic MHO Setting Screen

There are three basic settings, REACH, ANGLE, and OFFSET that will define the relay operating characteristic. REACH is a value in Ohms. ANGLE is a value in degrees normally associated with the maximum torque angle, line, or characteristic angle setting of the relay. OFFSET is a value in Ohms indicating either positive or negative offset. Pressing the Load Encroachment Edit button will reveal the Load Encroachment settings screen.

3.6.2.1.1 MHO Load Encroachment Setting Screen

For relays with Load Encroachment characteristics in the longer reaching zones of operation, pressing the Load Encroachment Edit button will reveal an appropriate settings dialog box.

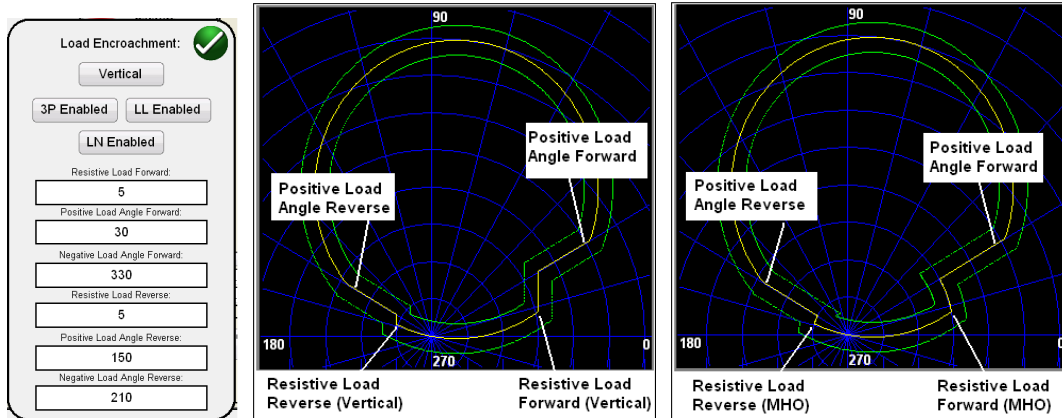

Figure 62 Load Encroachment Settings and Examples

The setting screen defaults to Vertical characteristic. Press the Vertical button to select for a MHO characteristic. To enable selective fault types press the appropriate button. It will change to yellow background and a checkmark will appear in the box. Enter the appropriate ohmic values and angles to achieve the desired characteristic.

3.6.2.2 HALF MHO Setting Screen

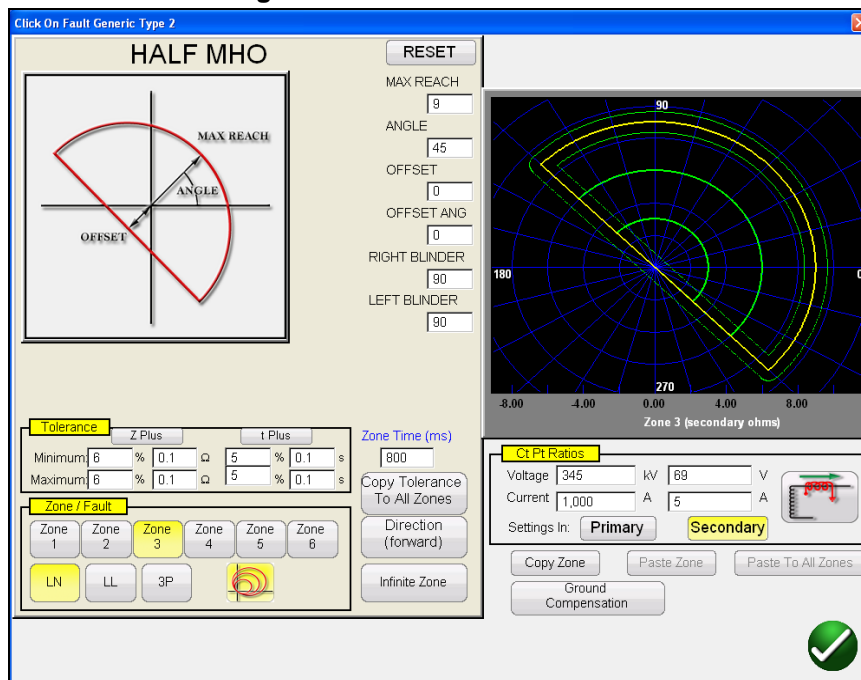

Figure 63 Half MHO Setting Screen

There are six basic settings, MAX REACH, ANGLE, OFFSET, OFFSET ANGLE, RIGHT BLINDER, and LEFT BLINDER that will define the relay operating characteristic. MAX REACH is a value in Ohms. ANGLE is a value in degrees normally associated with the maximum torque angle, line, or characteristic angle setting of the relay. OFFSET is a value in Ohms indicating either positive or negative offset. OFFSET ANGLE is a value in degrees, which may be different from the ANGLE setting. This setting is normally associated with the directional offset mho setting. RIGHT BLINDER and LEFT BLINDER are values in degrees

associated with blinder elements along the right and left sides of the original half MHO characteristic, and are angles relative to the ANGLE setting (note the default of 90 degrees or a right angle relative to the ANGLE setting). Virtually any MHO / OHM type characteristic can be molded using a combination of the BLINDER values ranging from pie shape to something greater than a Half MHO up to an OHM characteristic.

3.6.2.3 QUAD Setting Screen

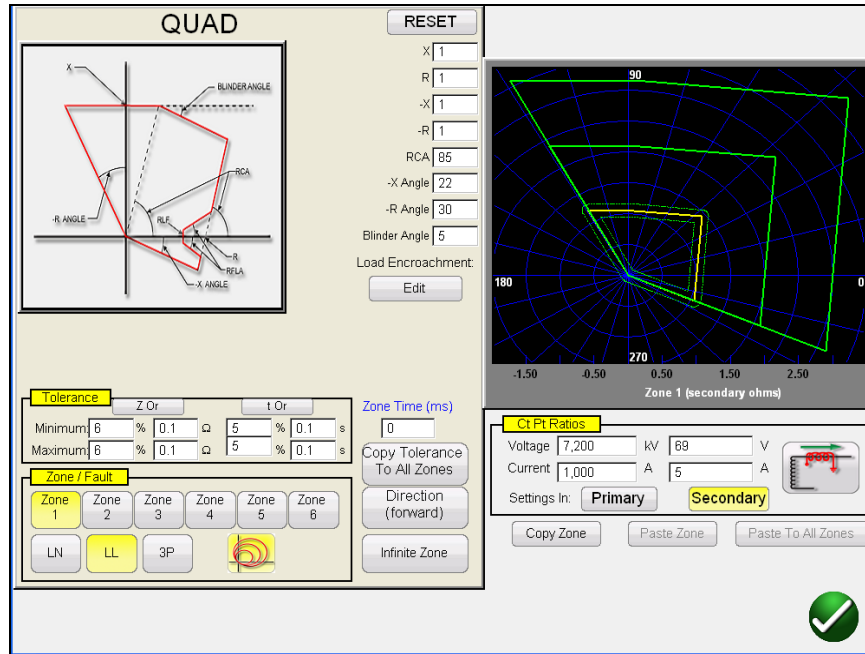

Figure 64 Generic QUAD Setting Screen

There are eight basic settings, X, R, -X, -R, RCA, -X Angle, -R Angle, and Blinder Angle that will define the relay operating characteristic. X and R are values in Ohms associated with the X and R axis, in an RX Impedance plane. The R value is normally referred to as the Positive Resistive Reach. The X value is normally referred to as the Positive Reactance Reach. The -X and -R are values in Ohms associated with -X and -R setting when the DIRECTIONAL setting is either set to NON-DIRECTIONAL or REVERSE settings. The -R value is normally referred to as the Negative Resistive Reach, and the -X value is normally referred to as the Negative Reactance Reach. The RCA is a value set in degrees normally associated with the maximum torque angle, line angle, or positive impedance characteristic angle setting of the relay. The -X and -R Angles are values in degrees normally associated with the Directional Characteristic Angles. Blinder Angle is a value in degrees, sometimes referred to as the Tilt Angle or a variant of the Positive Reactance Angle.

3.6.2.3.1 QUAD Load Encroachment Setting Screen

For relays with Load Encroachment characteristics in the longer reaching zones of operation, pressing the Load Encroachment Edit button will reveal the following settings dialog box.

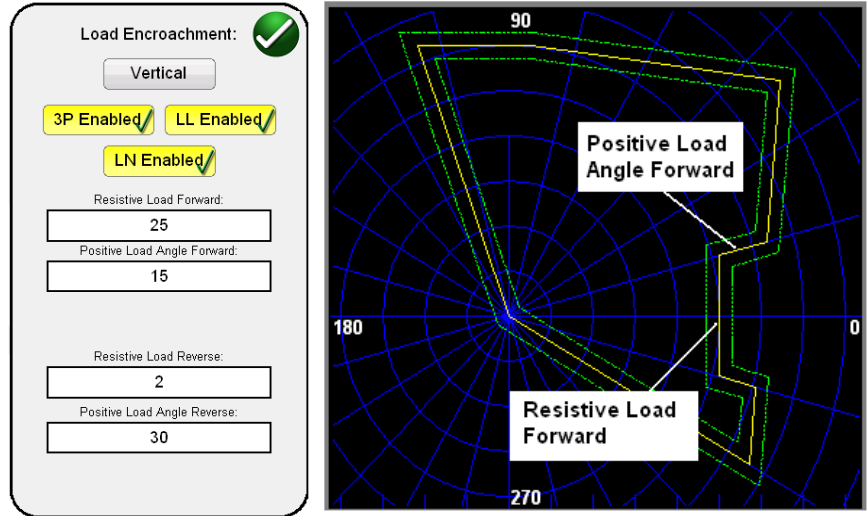

Figure 65 Example Load Encroachment Setting Screen for Generic QUAD

To enable selective fault types press the appropriate button. It will change to yellow background and a checkmark will appear in the box. Enter the appropriate ohmic values and angles to achieve the desired characteristic.

3.6.3 Relay Library Files

Pressing the Relay Library button will provide a selection window containing relay specific impedance characteristics listed by relay manufacturer and Model identifier. Future software updates will include more relay specific library files; see Upgrading STVI software for more information on downloading STVI software from the Megger website.

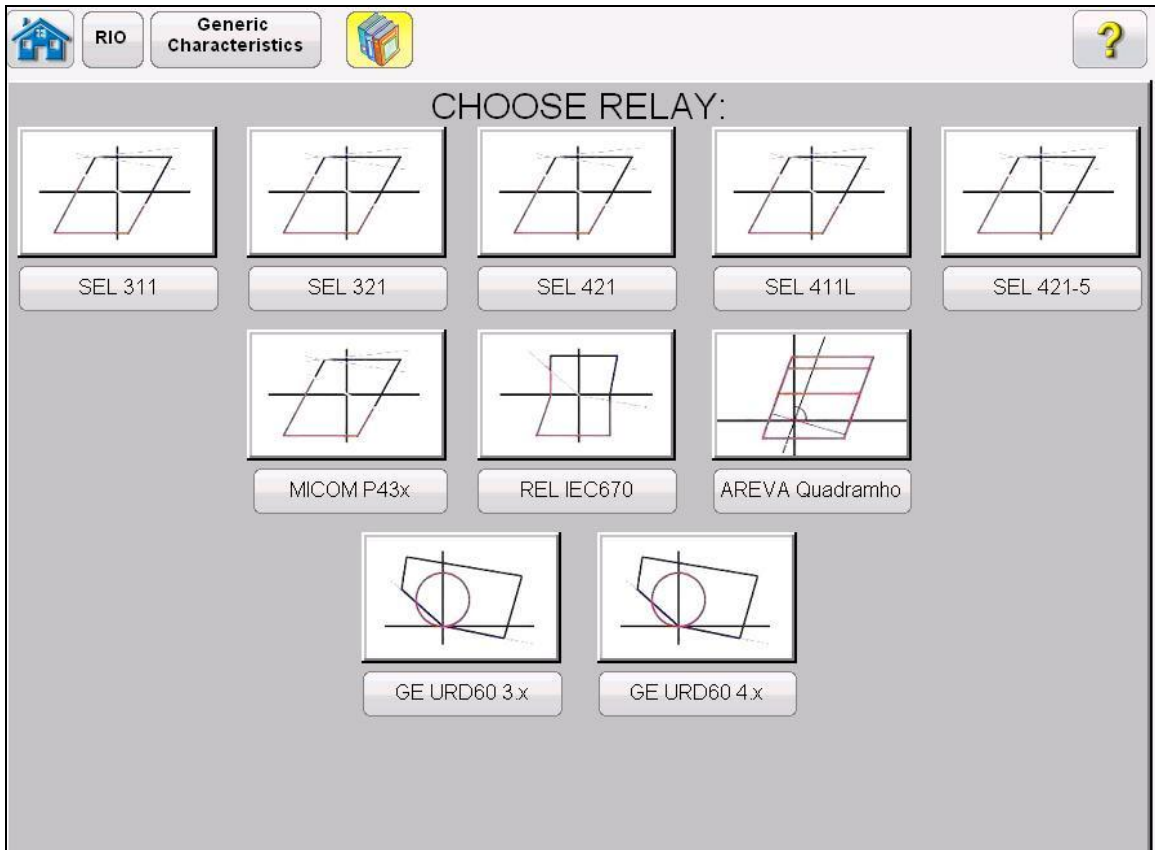

Figure 66 Relay Library Selection Screen

Impedance Relay Library

Select the desired relay and then enter the relay manufacturer's settings and the operating characteristic will be created from the settings entered. Note that specific relays have different characteristics depending on user input. Where relay may have multiple characteristics, selection buttons will be provided to choose from. For example, the Schweitzer SEL 311 and General Electric UR D60 relays have a selection for either Mho or Quad characteristics. The setting nomenclatures change with the selection of either Mho or Quad.

3.6.4 RIO Files

Pressing the RIO button will provide a selection window containing specific relays listed by relay manufacturer and Model identifier¹.

RIO files are created using relay and relay test software by various manufacturers. They may be considered to be Relay Impedance Objects, but are also allocated to other characteristics such as families of time-amplitude. RIO files constitute data for the characteristics of a particular relay with specific settings. Some or all the characteristic types may be created in the file and the characteristic relay settings will be included. I.e., the RIO files are relay

¹ Requires user to import the desired RIO files, in advance, into a RIO file folder under the MY Documents/PowerDB directory.

specific to the settings of the relay when the RIO file is created; the discrete settings are neither displayed nor adjustable. Once the relay is selected it will take the user to the Click On Fault Configuration Screen.

3.6.5 Impedance - Click On Fault Configuration Screen

After selection of either a Generic or a Library relay specific impedance characteristic, and entering the appropriate impedance settings for each of the specific Zones to be tested, press the green check button which will take the user to the Click On Fault Configuration Screen.

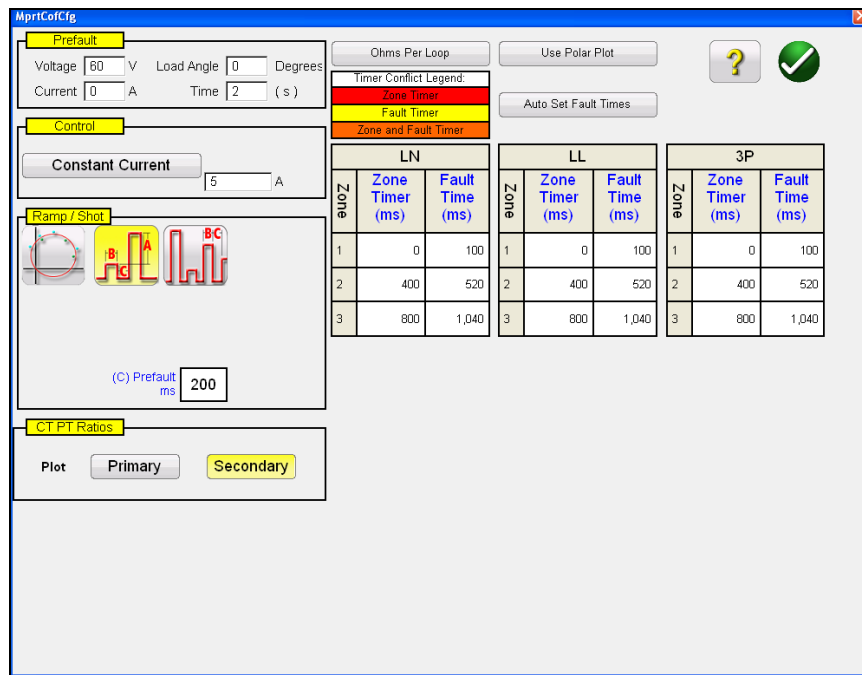

Figure 67 Impedance Relay, Click On Fault Configuration Screen

3.6.5.1 Prefault Dialog Box

The prefault values will be applied to the relay under test prior to ramping. If using Pulse Ramp the prefault values will be applied between each pulse increment. The Prefault Dialog box contains four edit fields:

- Voltage** – Enter a value of Voltage to be set
- Current** – Enter a value of Current to be set
- Load Angle** – Enter a value for a Load Angle to be set
- Time** – Enter the desired time prior to applying the first test point

3.6.5.2 Control Dialog Box

This dialog box provides the user with a selection of different methods to perform the tests. Some manufacturers require Constant Voltage and ramp current, some require Constant Current and ramp voltage. In addition, the user may also select Constant Source Impedance.

- Constant Voltage** - Enter the value of volts to be held constant for all Fault Types tests under execution. Default value is 5.0.
- Constant Current** - Enter the value of amperes to be held constant for all Fault Types tests under execution. Default value is 5.0.

Constant Source Z- There are two forms of Source Impedance; Ohms and Angle ,or R and X. Enter the value of ohms and angle of source to be held constant for all Fault Types tests under execution, or enter the R and X values where;

R: the Cartesian resistive equivalent of the impedance **[Z]** and its angle **Phi**

X: the Cartesian reactive equivalent of the impedance **[Z]** and its angle **Phi**

3.6.5.3 Ramp/Shot Options

This dialog box provides three different ways to determine the operating characteristic of impedance relays. Shots are used to create one or more test points to replicate a fault at a particular magnitude and angle. Trip (inside the operating characteristic) and/or No-Trip (outside the operating characteristic) points may be selected for each Fault Type. Selection of the type of Ramp is dependent on the relay. To test Multi-Zone relays use either the Pulse Ramp or Pulse Ramp Binary Search. The software will automatically calculate the increment required in volts, amps and phase angle. The Pulse Ramp and Pulse Ramp Binary Search also include a Prefault setting in milliseconds. This is the time that the prefault values will be applied between fault increments.

3.6.5.4 CT PT Ratios

This dialog box provides user selection for plotting the operating characteristic in either Primary or Secondary Ohms.

3.6.5.5 Polar/Rectangular Plot Button

This dialog box provides user selection for plotting the operating characteristic in either Polar or Rectangular coordinates.

3.6.5.6 Auto Set Fault Times button

This button works in conjunction with the Zone Timer settings window. You can change the Zone Trip and Fault Times by touching the appropriate setting window for the selected Zones. Pressing the Auto Set Fault Times button will automatically set the amount of time the fault will be applied to the relay. The Fault time is set in milliseconds, and automatically set to a value higher than the Expected Trip Time (just long enough for the zone being tested to operate, but not for other zones).

3.6.5.7 Ohms Per Phase/Per Loop button

This button works in conjunction with the Click On Fault Test Screen. For relays that use Loop Impedance Zero Sequence Compensation, press this button to read Ohms Per Loop to change the display to represent Ohms Per Loop.

3.6.6 Impedance - Click On Fault Test Screen

After selection of either a Generic or a Library relay specific impedance characteristic, and entering the appropriate impedance settings for each of the specific Zones to be tested, press the green check button which will take the user to the Click On Fault Test Screen.

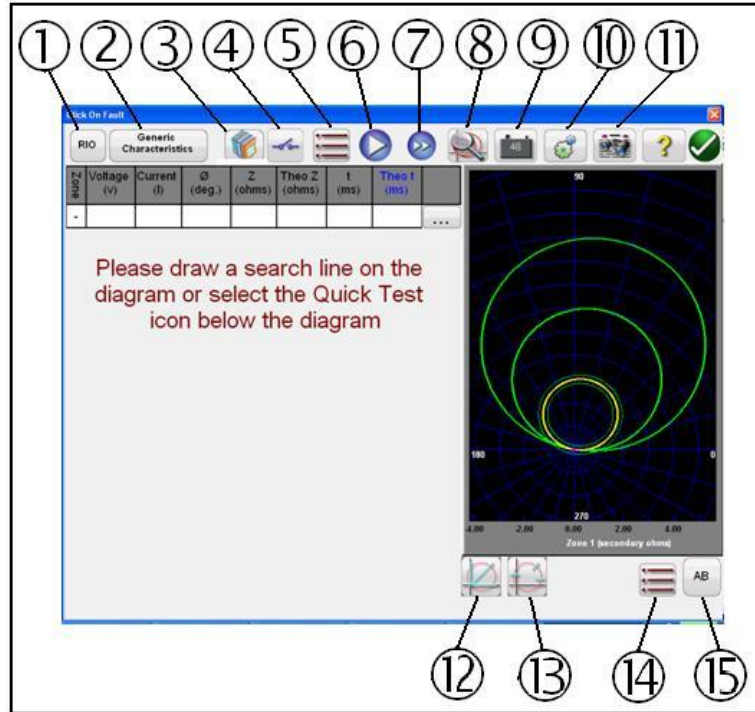
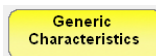

Figure 68 Impedance Relay, Click On Fault Test Screen

3.6.6.1 RIO button

Pressing the RIO button will provide a selection window containing specific relays listed by relay manufacturer and Model identifier².

3.6.6.2 Generic Characteristics button



Pressing the Generic Characteristics button will provide a library of generic impedance relay characteristics to choose from.

3.6.6.3 Relay Library button



Pressing the Relay Library will provide a library of relay specific characteristics by various manufacturers.

3.6.6.4 Binary Input Setting button



Press this box to reveal the Binary Input Dialog box.

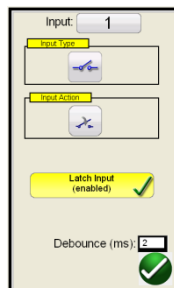

² Requires user to import the desired RIO files, in advance, into a RIO file folder under the MY Documents/PowerDB directory.

The default settings are Binary Input 1, dry contacts as indicated by the Input Type, and Input Action defaults to show the Closing of the Normally Open contacts. To change the Input Type from dry contacts to Voltage, press the Input Type icon, and it changes to voltage. To change to the opening of Normally Closed contacts press the Input Action icon and it changes to show closed contacts opening. For timing the operating time of the impedance element the timer is defaulted to Latched Input enabled mode, which means the timer will stop on the first contact closure. Note the Debounce time is set to 2 milliseconds.

3.6.6.5 Return to Settings Input Screen button

Return to the relay setting screen button provides access back to the settings screen.

3.6.6.6 Play button

Pressing or clicking the blue play button will apply the Prefault vector for the specified Time, then step to the Fault values and look for the relay under test to operate using either a Pulse Ramp or Pulse Ramp Binary Search. Pressing this button will play all of the selected test points for the selected fault type, for all the selected zones.

3.6.6.7 Test All button

Press the Test All button to automatically sequence through all defined tests, Phase to Ground, Phase to Phase, and Three Phase, for all zones.

3.6.6.8 Zone Zoom button

Pressing this button will zoom in on the selected zone. Press it again and return to the normal test screen mode.

3.6.6.9 Battery Simulator button

The Battery Simulator button – Turns the Battery Simulator ON and OFF by pressing the button, the color changes red for ON and black for OFF. The voltage to be applied is displayed in the button and can be changed by pressing the configuration button.

3.6.6.10 The Configuration button

Press the button to go to the STVI Configuration Screen. See Section 2.2.1 Configuration for more information of the Configuration Screen.

3.6.6.11 Review Test Report button

Press this button to review the test results.

3.6.6.12 Quick Test button

Three test lines will be drawn. One test line will be drawn along the Line Angle setting in the Settings screen. Any test lines can be deleted and redrawn by the user as desired using the



Run/Edit  button. Press the Run/Edit button for the individual test point. The user will then be presented with the following option screen.



Figure 69 Run/Edit Button Options

The user can; Edit the start impedance values, Run the selected test individually, Run the Remaining tests, or Delete the selected test. Press the red X to exit.

A second Quick Test option is available when you select your first test point using either the Independence test point's option, or the Origins test points option. Press this button  to reveal the following quick test point options.

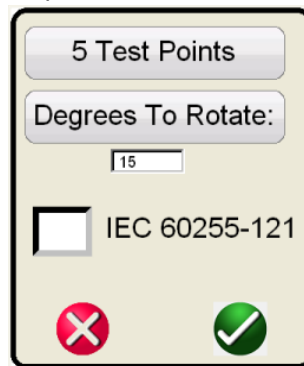

Figure 70 Test Points Selection Screen

The user may select the desired number of test points by pressing the Test Points button and select from the list. Then the user may select the desired phase rotation between the selected number of test points by pressing the Degrees to Rotate button. If none of the standard phase rotations meets the user's needs, press the Degrees to Rotate button in the list and enter the desired phase rotation in the window provided.

3.6.6.13 Independence Test Points option

The Independence Test Points option- This provides maximum freedom to the user to select any test line, at any angle, around the operating characteristic by clicking at a point outside and then inside the operating characteristic to define the desired test line. Press this button again to reveal the IEC60255 Test Points option.

3.6.6.13.1 IEC60255 Test Points option

The IEC60255 Test Points option- In accordance with IEC 60255 standard click a point outside, then inside, the operating characteristic and the test line will be drawn perpendicular to the operating characteristic line. Press this button to reveal the Origin Test Points option.

3.6.6.13.2 Origin Test Points option

The Origin Test Points option - Click a point outside the operating characteristic and the test line will be drawn to the origin or the intercept of the R and X axis. Press this button to return to the Independence option.



3.6.6.13.3 Shots Test Points option

The Shots Test Points option – Used to create one or more points of test, each to replicate a fault at a particular magnitude and angle. Several Trip (inside the operating characteristic) and/or No-Trip (outside the operating characteristic) points may be selected for each Fault Type. The **Test Point** is the set of values listed both in Mag and Phase Angle, and in Cartesian values that are created in the Graph. Continued clicks will produce additional test points at the mouse locations.

3.6.6.14 Return to Impedance COF Configuration Screen button



This button is used to return to the Impedance Click On Fault Configuration Screen to make selective changes to the test configuration.

3.6.6.15 Fault Selection button



This button provides user selection of the desired fault to be defined. The choices are Phase to Ground, Phase to Phase, and Three Phase.

3.6.6.16 Clear Test(s) button



This button only appears once tests are defined. Press this button to clear tests from the selected test screen. Pressing this button will provide a list of user options as follows,

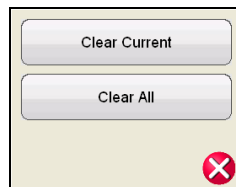



Figure 71 Clear Tests Options Screen

Clear Current – Clears the currently selected test

Clear All: This fault category – Clears all tests associated with the Fault

 Note: There is no going back; once you clear a test there is no way to recover the tests unless you have saved the test to the internal memory.

3.7 Testing Transducers with the STVI Software

In conjunction with the Transducer Hardware Option in the SMRT and MPRT8445 units, the STVI Transducer Test provides a quick approach to testing all types of single phase and three phase electrical transducers. The transducer hardware “T” option can either be ordered with the new test set or later as a factory hardware upgrade.

Press the Test List button  to get access to the STVI Transducer Test. Then press the



Transducer icon button. The Transducer Test Screen will appear.

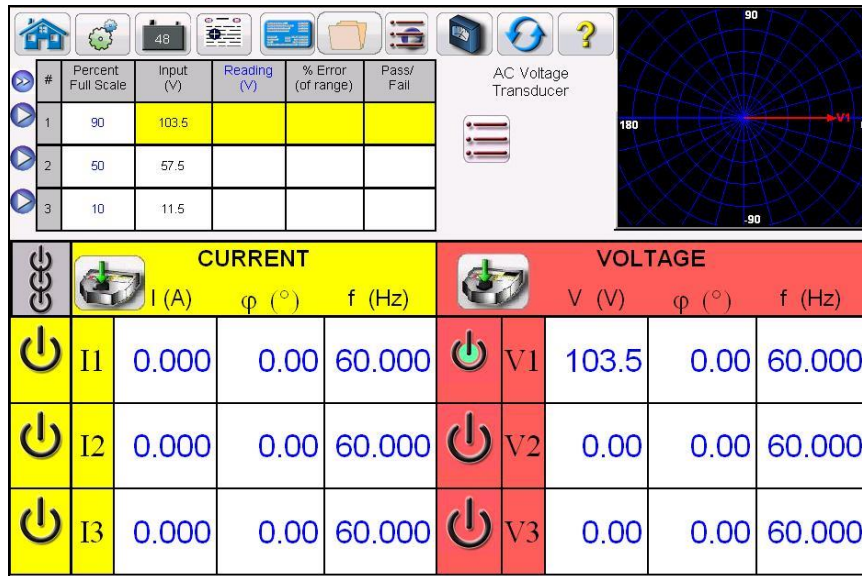

Figure 72 Transducer Test Screen

The test screen defaults to 3 test points set at 10, 50, and 90 percent of Full Scale. To change the number of test points, the percentage for each test point, or select the type of transducer to test, press the List button. The Transducer Setup Screen will appear.

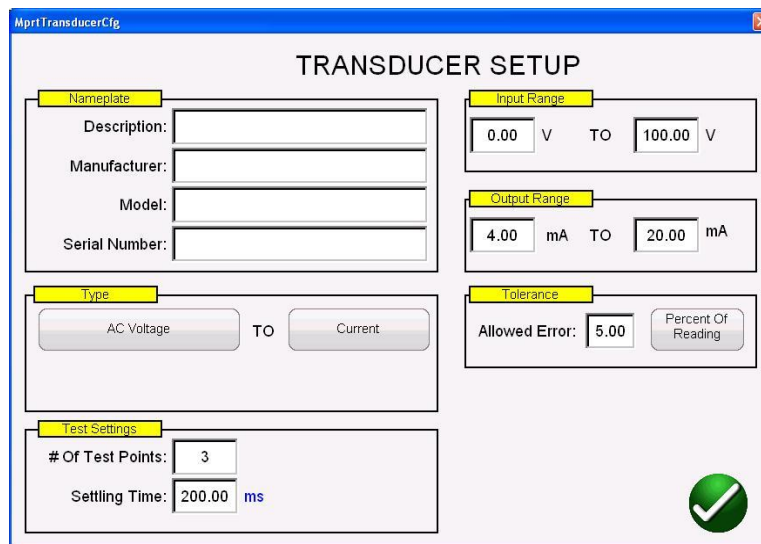

Figure 73 Transducer Setup Screen

This screen is used for selection of single phase or three-phase transducers such as; AC and DC Voltage, AC and DC Current, Frequency, Power (Watts), Reactive Power (VAR's), Apparent Power (VA) and Power Factor.

3.7.1 Transducer Setup Screen

The following are descriptions for each section within the Transducer Setup Screen.

3.7.1.1 Nameplate Section

In the description windows the operator enters descriptive information relative to the transducer to be tested. This information will be saved with the test results. The following describes the window entries.

Description: Input a short description of the transducer to be tested.

Manufacture: Input the name of the transducer manufacturer.

Model: Enter transducer model number .

Serial Number: Enter the serial number of the transducer.

3.7.1.2 Type Selection Section

The user may select from a variety of transducers, in the **Type** Section. Here the operator may select, by touching the selection window, the type of transducer that he/she needs to test. In addition the user selects the output of the transducer, either a voltage or a current output by pressing the provided button (toggles between Voltage and Current).

Watt, VAR and VA transducers come in 1, 1 ½, 2, 2 ½ and 3 element configurations.

Selecting the number of elements will automatically select the appropriate number of output voltages and currents needed to test the selected transducer. For example, selection of a single element Watt transducer, V1 and I1 sources will automatically be selected for you. In the case of a three-phase 3 element transducer V1, V2, V3, I1, I2 and I3 will be preselected for your use.

Selections available are:

Single Phase

AC Volts

AC Current

DC Volts

DC Current

Frequency

Watts / VAR / VA / Power Factor - 1 Element

Multi-Phase

Watts / VAR/ VA - 1 1/2 Element

Watts / VAR / VA - 2 Element

Watts / VAR / VA - 2 1/2 Element

Watts / VAR / VA / Power Factor - 3 Element

3.7.1.3 Test Settings Section

Some of the system default settings come from the **Configuration Screen**. The user can set the number of test points, the Settling Time, and when testing Watt, VAR, or VA whether to use Constant Current (and vary the voltage) or Constant Voltage (and vary the current).

Of Test Points: The software automatically defaults to 3 test points, 0, 50, and 90 % of Full Scale. The user can select any number of points from 1 to 5. In the Test Screen the user can enter what % of Full Scale for each test point.

Settling Time: This is the time delay, in milliseconds, the test system will wait before making it's first accuracy calculation and freeze the readings. If the transducer

is self energized, the operator needs to allow enough time for the transducer to stabilize before making an accuracy calculation. If the transducer needs warmup time prior to testing, the operator needs to account for this time too. On the other hand, if the transducer is already warmed and is powered-up, then the operator only needs to allow for the settling time of the transducer. For example, assume the transducer settling time is 1 second, then the operator needs to enter a settling time of 1,000 milliseconds. When the test values are applied, the system will wait 1,000 milliseconds before calculating the % error deviation. Then, the % error with pass/fail information is displayed and the test values are frozen. At this point the operator may choose to Stop the test and Save results.

Constant Current: If the operator chooses Watt, VAR or VA in the **Type** window, a Full Scale voltage (based upon the current value entered) will automatically be calculated and entered for you. The value will be calculated based on the Watts, VAR or VA value entered in the **Input Range** Section. The current value will automatically default to 5 Amps. The user is free to change the value to any desired fixed output current in the window provided.

Constant Voltage: Pressing the Constant Current button changes the output configuration to Constant Voltage. A Full Scale current (based upon the voltage value entered) will automatically be calculated and entered for you. To change the value, press the display window and enter the desired voltage value.

3.7.1.4 Input Range Section

The operator inputs the full scale input range of the transducer to be tested. For example an AC Current Transducer may have a range of 0 to 1, or 0 to 5 Amps. Enter the appropriate values for the transducer to be tested.

3.7.1.5 Output Range Section

Output Range: Depending upon the type of output selected in the Type section, the transducer will have either a dc voltage or dc milliamper output. The default settings are 0 to 10 Volts dc, and 4 to 20 milliamperes dc. It should be noted that Minimum Value could be a negative dc value. For example, - 1 milliamper, or - 10 Volts dc. It could also be a positive dc value, other than 0. The firmware will calculate the scaling factor based on the minimum and maximum values, and use this scaling factor to calculate the actual output from the transducer (in terms of Volts, Amperes, Watts etc).

Voltage or Current : The operator selects one by touching the button associated with either the **Voltage** or **Current**. If the Min. and / or Max. are different from the defaulted values, the operator touches the appropriate window and a numeric keypad will appear on the STVI to enter the appropriate value(s). In the following example, the transducer is a Watt transducer. When **Watt 3 Element** was selected in the **Select Transducer Type** window, **W** (Watts) appears in the Transducer Input range window.

In this example, a value of 1500.0 was entered as the maximum input. The Output Range was set 0 to 1.00 milliamperes. Therefore, the scaling factor will be,
 $0 \text{ mA} = 0.0 \text{ Watts}$, and $1.000 \text{ mA} = 1500.0 \text{ Watts}$ or,

$$1\text{mA} / 1500.0 \text{ W} = 0.00066666 \text{ mA} / \text{Watt}$$

Therefore, if the transducer had a measured output of .250 mA, then the equivalent Watts output would be,

$$0.250 \text{ mA} / 0.00066666 \text{ mA/W} = 375.0 \text{ Watts}$$

Tolerance: The accuracy value for the transducer is entered here. The default value is in Percent of Range (or Full Scale). To change to Percent of Reading touch the Percent of Range button. To enter another value, the user touches the value window and a keypad allows another value to be entered.

With all the values entered in the Transducer Setup Screen, to return to the Transducer Test Screen press the green check  button at the bottom of the screen.

3.7.2 Transducer Test Screen

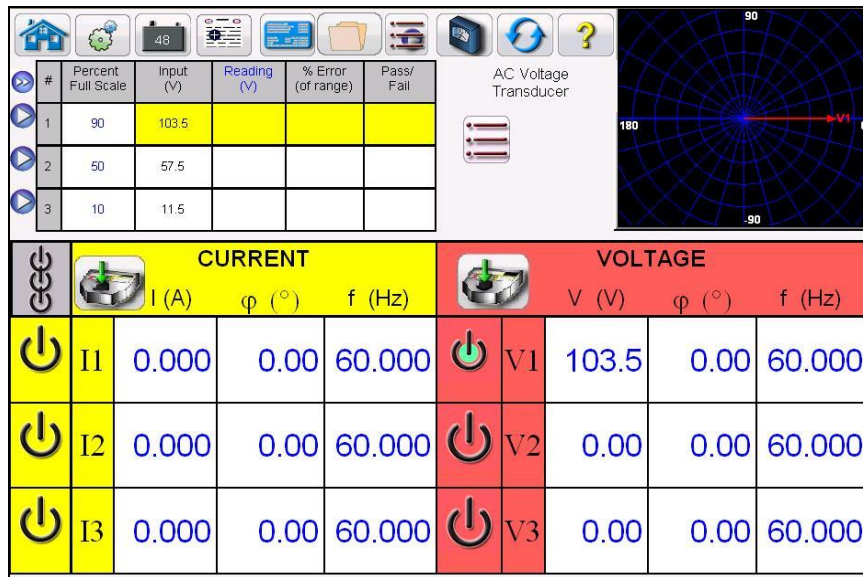

#	Percent Full Scale	Input (V)	Reading (V)	% Error (of range)	Pass/Fail
1	90	103.5			
2	50	57.5			
3	10	11.5			

CURRENT				VOLTAGE			
	I (A)	φ (°)	f (Hz)		V (V)	φ (°)	f (Hz)
I1	0.000	0.00	60.000	V1	103.5	0.00	60.000
I2	0.000	0.00	60.000	V2	0.00	0.00	60.000
I3	0.000	0.00	60.000	V3	0.00	0.00	60.000

The **Transducer Test Screen** has three parts. The **Output** section where the test values to be applied to the transducer appear, the **Transducer Output** section where the DC Reading, % Error and Pass/Fail appear, and the **Vector** Section.

3.7.2.1 Output Section

The operator can select which outputs to turn on/off or value to be changed or incremented. When selecting the type of transducer to test in the Setting Screen, the appropriate outputs will automatically be selected for the user. For example, if an AC Voltage transducer had been selected, the V1 output selection button will have

changed to green, and the defaulted voltage would appear. In the above example a single phase AC Voltage Transducer was selected, with a Full Scale Input of 100 Volts. The first default test point is 90% of Range. Therefore, a test value of 90 Volts appears for V1 output. The default frequency will also be preset. If a DC transducer had been selected, the Freq. Window for the selected voltage or current would read DC.

3.7.2.2 Transducer Output Section

In the following example, a 3 Element 1,500 Watt transducer was selected in the **Setting Screen**. It automatically defaults to 3 test points of 0, 50, and 90 % of Full Scale, note the calculated Watts to be applied. Pressing the blue play button will apply the test values as displayed in the Input column. This value will be used later to calculate % error and PASS / FAIL.

#	Percent Full Scale	Input (W)	Reading (V)	Reading (W)	% Error (of range)	Pass/Fail	Watt (3 Elements) Transducer
1	90	1,350					
2	50	750					
3	10	150					

The transducer output section displays either the dc output Volts or Milliampères (Reading V or mA). In addition, it also displays the equivalent output in the select type value (Reading V, A, Watts, VA etc). Depending on the desired measurement set in the setting screen the % Error will be either of range, or of reading. From this the Pass/Fail will be determined and displayed.



The accuracy is calculated as follows,

$$\left(\frac{\text{Transducer Output} - \text{Measured Output}}{\text{Measured Output}} \right) \times 100$$

If the value displayed in the Accuracy window meets the Accuracy specification set in the Transducer Setup Screen, an affirmative PASS will be displayed. If it exceeds the setting specifications, a negative FAILED will appear.

3.7.3 Testing Transducers

1. In the Transducer Setup Screen, enter the transducers specific data, such as manufacturer, model number and serial number.
2. Select the transducer type to be tested.

3. Enter the transducer's output in dc volts or milliamperes. Include the min. and max. values for the type of output, which correlates to the voltage or current. Input the transducer's accuracy value.
4. Enter the transducer's settling, or response time in milliseconds (allow extra time for self powered transducers).
5. Press the green check  button at the bottom of the screen.
6. Based on the type of transducer selected the appropriate outputs will have already been pre-selected for you. The outputs selected will be green  in color. In the case of Watt, VAR or VA transducers, the angles have already been preset. If you desire to test at some other value(s) than those preset, press the window for the value(s) you wish to change and a numeric keypad will appear. Using the keypad, enter the desired value(s).
7. Connect the selected outputs to the appropriate transducer's input terminals.
8. If the transducer requires an external power source (for the AUX. Power input), connect your external power source at this time.
9. Press the **blue play** button next to the desired test point. The outputs will turn on.
10. Note the test result in the Transducer Output section of the window.

3.7.4 Saving Results

1. With the test completed, the results and test file need to be saved to the internal solid-state disk. To do this, press the **File** button. This will take the user to the **Save As** window.
2. Enter a file name, and press the Save As button. The test and data are now saved. See **File Manager** section for additional information.

3.7.5 Watt / Var / Va / Power Factor Applications

As previously described, Watt and VAR transducers come in 1, 1 1/2, 2, 2 1/2 and 3 Element configurations. In the Transducer Setup Screen, the operator is required to select what type of transducer is to be tested. Once selected, the STVI software will make certain assumptions and calculations based on the number of elements selected. The following are detailed descriptions of the different elements and the calculations required to calculate Watts and / or VARs.

3.7.5.1 Watt/VAR 1 Element

The single element watt transducer requires 1 voltage and 1 current to test. The test set will automatically select the first voltage and current channels available, **V1** and **I1**. The test will initially start at the default value voltage unless changed by the user (select constant voltage and enter the desired output voltage). For example, 120.0 Volts L-N. When the user inputs the Watts value in the **Transducer Setup Screen**, the firmware can calculate the required test current for full scale value. Since the default angle will be 0° (zero degrees), the calculation is simple. The formula required to calculate Watts is,

$$V1 * I1 * \text{COS } 0^\circ = \text{Watts}$$

Example: The default voltage is 120.00 Volts AC, and the user inputs 500 Watts as Max. Value. The current required for **full scale** output from the transducer is,

$$120 * I_1 * \text{COS } 0^\circ = 500 \text{ Watts} \quad \text{simplifying, } I_1 = 500/120, \text{ or } I_1 = 4.1667 \text{ Amperes}$$

Note that the first default test point is set to 90 % of Full Scale, which will result in a test current of 3.750 Amps. Therefore, if the user wants to test at the full scale input of 500 Watts, in the Test Screen touch the percent full scale window and enter 100. The test should automatically show a test current value of 4.167 Amperes at an angle of 0°. Note, the voltage is also in-phase with the current at 0°. Also, note that the current is rounded up to 7 in the last digit displayed.

When the test is Started, the measured voltage and current outputs are displayed and the calculated Watts is based on the measured voltage and current outputs. This is the value that gets displayed in the 2nd column of the **Transducer Output** section. The 3rd column will display the measured dc output from the transducer. Another value of Watts gets calculated using the measured dc Volts or dc milliampere output as displayed in the 4th column. The percent error will be displayed in the 5th column. Let us assume that in our example transducer, the output is in dc milliamperes. For this example, let us say that 1 milliampere of dc current is equal to the full scale output of 500 Watts. Therefore, the theoretical output Watts from the transducer would be 500 Watts, if the output current is 1 milliampere. For this example, let's say that the measured output voltage is 120.01 Volts, at 0°, and the measured output current is 4.166, Amperes, at 0.0°. The measured output Watts would be,

$$120.01 * 4.166 * \text{COS } 0.0 = 499.96 \text{ Watts}$$

For this example, let's assume the measured output current from the transducer is 0.996 mA dc. Based on a Max. value of 1 mA equals 500 Watts, the displayed **Watts** in the **Transducer Output** section of the **Transducer Test Screen** should read $500 * 0.996 = 498.0 \text{ Watts}$

The **Accuracy** displayed in the **Transducer Output** section would be equal to the following, $(498.0 - 499.96 / 499.96) * 100 = \% \text{ accuracy}$ or -0.392 %

If this were a 0.5 % transducer, then the firmware would compare the accuracy values between the Setting Screen and the Test Screen and would display **PASS** in the **Transducer Output** section of the test screen. If this were a 0.2 %, then it would display **FAILED**.

Note: All of the calculations are very similar when testing VAR 1 Element transducers. The primary difference is replacing the COS function with the SIN function.

Note: Calculations for VA transducers are the same except there are no COS or SIN functions. Therefore, the apparent power (VA) calculation is simplified as Volts * Amps. For example, for the calculation above the apparent power is,

$$120.01 * 4.166 = 499.96 \text{ VA}$$

3.7.5.2 Power Factor 1 Element

The single element power factor transducer requires 1 voltage and 1 current to test. The test set will automatically select the first voltage and current channels available, **V1** and **I1**. The test will initially start at the default values for voltage and current. For example, 120 Volts L-N, and 5 Amperes. The Power factor transducer has a range of operation that correlates to the Leading or Lagging phase angle relationship between the voltage and current inputs. Therefore, when the user selects Power Factor 1 Element, the **MIN** and **MAX** nomenclature will change to read **LEAD** and **LAG** power factor values. The user is required to input the **LEAD (MIN)** and **LAG (MAX)** power factor values into the provided spaces (normally the same values, i. e. 0.5). The power factor is the trigonometric decimal equivalent value of the COS of the angle between the V1 voltage and I1 current. For example, when the user inputs the **LEAD** and **LAG** Power Factor values in the **Transducer Setup Screen**, the firmware can calculate the required test angles for full scale values. Thus for a **LAG** Power Factor value of 0.5, the current would need to lag the voltage by 60°. The Lead and Lag phase angles require that the vector display be changed to show angles as $\pm 180^\circ$. If the default angle representation is 0 to 360 LAG, then the angle between the voltage and current will be considered lagging (current lags voltage). In this situation, the typical test angles may vary between 0 to 90 degrees lag and 359.9 to 270 degrees lag (90 degrees leading). This could cause some confusion to the user. By forcing the display to $\pm 180^\circ$ simplifies the testing considerably. The test will start at unity power factor, or $\pm 0^\circ$. Since the default angle will be 0° (zero degrees), the calculation is simple. The formula required to calculate Power Factor is,

$$\text{COS } \angle 0^\circ = 1.000 \text{ Power Factor } (V1 \angle 0^\circ, I1 \angle 0^\circ)$$

Example: The default voltage is 120.00 Volts and current is 5 Amperes AC, and the user inputs a Power Factor of ± 0.3 as **LEAD** and **LAG** Values. The angles required for full scale output from the transducer is,

$$0.3 \text{ Power Factor} = \text{COS } 72.5^\circ \quad \text{or, } +72.5^\circ \text{ LEAD and } -72.5^\circ \text{ LAG}$$

When the test is Started, the measured voltage and current outputs are displayed and the calculated Power Factor is based on the measured phase angle between the voltage and current outputs. This is the value that gets displayed in the **Transducer Test Screen** under the **Reading (V or mA) column**.

Another value of Power Factor gets calculated using the measured dc Volts or dc milliamper output as displayed in the **Transducer Output** section. Let us assume that in our next example transducer, the output is in dc milliamperes. For this example, let us say that ± 1 milliamper of dc current is equal to the full scale Power Factor of ± 0.5 . Therefore, the theoretical range of output from the transducer would be - 0.5 Power Factor, if the output current is -1 milliamper, to +0.5 Power Factor, if the output current is +1 milliamper. For this example, let's say that the measured

output voltage is 120.0 Volts, at 0°, and the measured output current is 5.000 Amperes, at a lagging angle of - 30°. The calculated Power Factor would be,

$$\text{COS } -30^\circ = - \mathbf{0.866}$$

For this example, let's assume the measured output current from the transducer is - 0.489 mA dc. Based on a Lead/Lag value of ±1 mA equals ±0.5 PF, the scaling would be equal to

$$0.5 \text{ PF} = \text{COS } 60^\circ$$

$$1 \text{ mA} / 60^\circ \text{ or } 0.016666 \text{ mA per degree.}$$

Therefore, the displayed **PF** in the **Transducer Output** section of the **Transducer Test Screen** should read

$$- 0.489 \text{ mA} / 0.016666 \text{ mA/Degree} = - 29.34 \text{ Degrees}$$

$$\text{COS } - 29.34^\circ = - \mathbf{0.871 \text{ PF}}$$

Power factor transducer accuracies are stated in units of Power Factor, not in % error. Therefore, the **Accuracy** window for Power Factor transducers needs to change from % error to ± **0.000 PF**. The **Accuracy** displayed in the **Transducer Output** section would be equal to the following,

$$0.871 - 0.866 = + \mathbf{0.005 \text{ PF}}$$

If this were a 0.01 PF transducer, then the firmware would compare the accuracy values between the Setting Screen and the Test Screen and would display **PASS** in the **Transducer Output** section of the test screen.

3.7.5.3 Watt/VAR1 1/2 Element

This transducer is normally used in single-phase, three wire applications, which requires 2 voltages and 2 currents to test. The test set will automatically select the first two voltage and current channels available, **V1**, **V2**, **I1** and **I2**. The voltage input to the transducer is supplied with one voltage input terminal. However, we must take into account that the transducer is connected using a PT that is connected line to line. Thus the test will initially start at the default voltage value, that is set in the **Default Setting Screen**, for each Voltage output. However, the V2 output will be 180 degrees out of phase with V1, thus they add across the potential input of the transducer. For example, a default of 120 Volts L-N, means 240 Volts will be impressed across the transducer potential input terminals. Thus V1 will be set to 120 Volts at an angle of 0°, and V2 will be 120 Volts at 180°. I1 and I2 will be in-phase with their respective voltages (0° and 180°). When the user inputs the **MAX.** Watts value in the **Transducer Setup Screen**, the firmware can calculate the required test currents for full scale value.

The formula required to calculate Watts for 1 1/2 Element transducer is,

$$V1 * I1 * \text{COS } \varnothing + V2 * I2 \text{COS } \varnothing = \text{Watts}$$

Example: The default voltage is 120.00 Volts AC, and the user inputs 1000 Watts as Max. Value. The current required for full scale output from the transducer is,

$$120 * I1 * \text{COS } 0^\circ + 120 * I2 * \text{COS } 0^\circ = 1000 \text{ Watts}$$

Since each phase contributes half of the power, we can simplify to,

$$I1 = 500 \text{ Watts}/120 \text{ Volts, or } I1 = I2 = 4.1667 \text{ Amperes}$$

Therefore, when the user inputs 1000 Watts in the **MAX.** value window, in the Test Screen the test set should automatically show a test current value for I1 of 4.167 Amperes at an angle of 0°, and I2 will be 4.167 Amperes at an angle of 180°. Note that the current is rounded up to 7 in the last digit displayed.

When the test is Started, the measured voltage and current outputs are displayed and the calculated Watts is based on the measured voltage and current outputs. This is the value that gets displayed in the **Transducer Test Screen** under the **Output**. Another value of Watts gets calculated using the measured dc Volts or dc milliampere output as displayed in the **Transducer Output** section. Let us assume that in our example transducer, the output is in dc milliamperes. For this example, let us say that 1 milliampere of dc current is equal to the full scale output of 1000 Watts. Therefore, the theoretical output Watts from the transducer would be 1000 Watts, if the output current is 1 milliampere. For this example, let's say that the measured output voltages are 120.00 Volts (V1 and V2) and the measured output currents are 4.166, Amperes, at 0°. The measured output Watts would be,

$$120.00 * 4.166 * \text{COS } 0^\circ + 120.00 * 4.166 * \text{COS } 0^\circ = 999.94 \text{ Watts}$$

For this example, let's assume the measured output current from the transducer is 0.998 mA dc. Based on a Max. value of 1 mA equals 1000 Watts, the displayed **Watts** in the **Transducer Output** section of the **Transducer Test Screen** should read $1000 * 0.998 = 998.00 \text{ Watts}$

The **Accuracy** displayed in the **Transducer Output** section would be equal to the following,

$$(998.0 - 999.98 / 999.98) * 100 = \% \text{ accuracy } \text{ or } -0.198 \%$$

If this were a 0.2 % transducer, then the firmware would compare the accuracy values between the Setting Screen and the Test Screen and would display **PASS** in the **Transducer Output** section of the test screen.

Note: All of the calculations are very similar when testing VAR 1 1/2 Element transducers. The primary difference is replacing the COS function with the SIN function.

3.7.5.4 Watt/VAR 2 Element

This transducer is normally used in three-phase, three wire delta application, which requires 2 voltages and 2 currents to test. Normally, the PT's and CT's are connected to A and C phases. The test set will automatically select two voltage and current channels, **V1, V3, I1** and **I3** (in the event that there is no V3/I3 channel, then V2 and I2 will be used). The test will initially start at the default voltage value, that is set in the **Default Setting Screen**, for each Voltage output. Thus, for a default voltage setting of 120 volts, V1 will be set to 120 Volts at an angle of 0°, and V3 will be 120 Volts at 300° (delta connected PT's). This assumes that the default phase angle is 0 - 360 Degrees lag, and not +/- 180 degrees. If the +/- 180 degree phase angle option is used, then V3 will be at +60°. I1 and I3 will be phase shifted 30° with their respective voltages, or I1 at 30° lag and I3 at 270° lag (or + 90°). When the user inputs the **MAX.** Watts value in the **Transducer Setup Screen**, the firmware can calculate the required test currents for full scale value.

The formula required to calculate Watts for 2 Element transducer is,

$$V1 * \sqrt{3} * I1 * (\cos 30^\circ + \phi) + V3 * \sqrt{3} * I3 * (\cos 30^\circ - \phi) = \text{Total Watts}$$

Where ϕ is the incremental angular change between V1 and I1 and V3 and I3.

Example: The default voltage is 120.00 Volts AC, and the user inputs 1000 Watts as Max. Value. The current required for full scale output from the transducer is,

$$120 * \sqrt{3} * I1 * \cos 30^\circ + 120 * \sqrt{3} * I3 * \cos 30^\circ = 1000 \text{ Watts}$$

$$I1 = 500 \text{ Watts} / (120 \text{ Volts} * \sqrt{3} * \cos 30^\circ) , \text{ or } I1 = 500/180.00$$

Since $I1 = I3$, then I1 and I3 will be 2.7777 Amperes each

Therefore, when the user inputs 1000 Watts in the **MAX.** value window, in the Test Screen the test set should automatically show a test current value for I1 of 2.777 Amperes at an angle of 30°, and I3 will be 2.777 Amperes at an angle of 270° (+90°).

When the test is Started, the measured voltage and current outputs are displayed and the calculated Watts is based on the measured voltage and current outputs. This is the value that gets displayed in the **Transducer Test Screen** under the **Output**. Another value of Watts gets calculated using the measured dc Volts or dc milliamper output as displayed in the **Transducer Output** section. Let us assume that in our example transducer, the output is in dc milliamperes. In this example, let 1 milliamper of dc current be equal to the full scale output of 1000 Watts. For this example, let's say that the measured output voltages are 120.00 Volts (V1 and V3) and the measured output currents are 2.793, Amperes. The measured output Watts would be,

$$120.00 * \sqrt{3} * 2.793 * \text{COS } 30^\circ + 120.00 * \sqrt{3} * 2.793 * \text{COS } 30^\circ = 1005.48 \text{ Watts}$$

For this example, let's assume the measured output current from the transducer is 1.001 mA dc. Based on a Max. value of 1 mA equals 1000 Watts, the displayed **Watts** in the **Transducer Output** section of the **Transducer Test Screen** should read $1000 * 1.001 = 1001.00 \text{ Watts}$

The **Accuracy** displayed in the **Transducer Output** section would be equal to the following,

$$(1001.00 - 1005.48 / 1005.48) * 100 = \% \text{ accuracy} \quad \text{or } -0.445 \%$$

If this were a 0.5 % transducer, then the firmware would compare the accuracy values between the Setting Screen and the Test Screen and would display **PASS** in the **Transducer Output** section of the test screen.

If the user adjusts the phase angle in the lagging direction by an additional 30°, then the Watts output changes.

Using the formula,

$$V1 * \sqrt{3} * I1 * (\text{COS } 30^\circ + \emptyset) + V3 * \sqrt{3} * I3 * (\text{COS } 30^\circ - \emptyset) = \text{Total Watts}$$

Where \emptyset is the incremental angular change of 30° between V1 and I1 and V3 and I3,

$$120.00 * \sqrt{3} * 2.793 * \text{COS } (30^\circ + 30^\circ) + 120.00 * \sqrt{3} * 2.793 * \text{COS } (30^\circ - 30^\circ)$$

$$\text{then, Total Watts} = 283.7099 + 580.5142 \quad \text{or } 864.22 \text{ Watts}$$

Note: All of the calculations are very similar when testing VAR 2 Element transducers. The primary difference is replacing the COS function with the SIN function. For the example above,

$$120.00 * \sqrt{3} * 2.793 * \text{SIN } (30^\circ + 30^\circ) + 120.00 * \sqrt{3} * 2.793 * \text{SIN } (30^\circ - 30^\circ)$$

$$\text{then, } 502.7397 + 0 = 502.74 \text{ VAR}$$

Note: For apparent power, VA, transducers, the calculations remain the same, except there are no COS or SIN functions. For the example above,

$$120.00 * \sqrt{3} * 2.793 + 120.00 * \sqrt{3} * 2.793 = 1161.03 \text{ VA}$$

3.7.5.5 Watt/VAR 2 1/2 Element

This transducer is normally used in three-phase, four wire Wye applications, which requires 2 voltages and 3 currents to test. The two voltages and three currents are all referenced to ground. The test set will automatically select two voltage and three

current channels, **V1, V3, I1, I2** and **I3**. The test will initially start at the default voltage value, that is set in the **Default Setting Screen**, for each Voltage output. Thus, for a default voltage setting of 120 volts, V1 will be set to 120 Volts at an angle of 0°, and V3 will be 120 Volts at 240° lagging. This assumes that the default phase angle is 0 - 360 Degrees lag, and not +/- 180 degrees. If the +/- 180 degree phase angle option is used, then V3 will be at +120°. I1 and I3 will be in-phase with their respective voltages, or I1 at 0° and I3 at 240° lag (or + 120°). I2 will be at 120° lag (or -120°). When the user inputs the **MAX.** Watts value in the **Transducer Setup Screen**, the firmware can calculate the required test currents for full scale value.

The formula required to calculate Watts for 2 1/2 Element transducer is,

$$V1 * I1 * (\text{COS } \emptyset) + V3 * I3 * (\text{COS } \emptyset) + V1 * I2 * (\text{COS } 60^\circ + \emptyset) + V3 * I2 * (\text{COS } 60^\circ - \emptyset) = \text{Total Watts}$$

Where \emptyset is the incremental angular change between V1 and I1 and V3 and I3, with I2 changing at the same incremental angle as I1 and I3.

Example: The default voltage is 120.00 Volts AC, and the user inputs 1500 Watts as Max. Value. The current required for full scale output from the transducer is,

$$120 * I1 * \text{COS } 0^\circ + 120 * I3 * \text{COS } 0^\circ + V1 * I2 * (\text{COS } 60^\circ + 0^\circ) + V3 * I2 * (\text{COS } 60^\circ - 0^\circ) = 1500 \text{ Watts}$$

$$I1 = 500 \text{ Watts} / (120 \text{ Volts} * \text{COS } 0^\circ) , \text{ or } I1 = 500 / 120$$

then I1, I2 and I3 will be 4.1667 Amperes each

Therefore, when the user inputs 1500 Watts in the **MAX.** value window, the test set should automatically show a test current value for I1 of 4.167 Amperes at an angle of 0°, I2 will be 4.167 at 120° (-120°) and I3 will be 4.167 Amperes at an angle of 240° (+120°). Note that the current is rounded up to 7 in the last digit displayed.

When the test is Started, the measured voltage and current outputs are displayed and the calculated Watts is based on the measured voltage and current outputs. This is the value that gets displayed in the **Transducer Test Screen** under the **Output**. Another value of Watts gets calculated using the measured dc Volts or dc milliamperes output as displayed in the **Transducer Output** section. Let us assume that in our example transducer, the output is in dc milliamperes. In this example, let 20 milliamps of dc current be equal to the full scale output of 1500 Watts. For this example, let's say that the measured output voltages are 120.02 Volts (V1 and V3) and the measured output currents are 4.166, Amperes. The measured output Watts would be,

$$120.02 * 4.166 * \text{COS } 0^\circ + 120.02 * 4.166 * \text{COS } 0^\circ + 120.02 * 4.166 * (\text{COS } 60^\circ + 0^\circ) + 120.02 * 4.166 * (\text{COS } 60^\circ - 0^\circ) = \text{or, } 500.0332 + 500.0332 + 250.0166 + 250.0166$$

1500.10 Watts

For this example, let's assume the measured output current from the transducer is 20.1 mA dc. Based on a Max. value of 20 mA equals 1500 Watts, the displayed **Watts** in the **Transducer Output** section of the **Transducer Test Screen** should read **1507.5 Watts**

The **Accuracy** displayed in the **Transducer Output** section would be equal to the following,

$$(1507.5 - 1500.10 / 1500.10) * 100 = \% \text{ accuracy } \text{ or } 0.493\%$$

If this were a 0.5 % transducer, then the firmware would compare the accuracy values between the Setting Screen and the Test Screen and would display **PASS** in the **Transducer Output** section of the test screen.

If the user adjusts the phase angle in the lagging direction by 30°, then the Watts output changes.

Using the formula,

$$V1 * I1 * (\text{COS } \emptyset) + V3 * I3 * (\text{COS } \emptyset) + V1 * I2 * (\text{COS } 60^\circ + \emptyset) + V3 * I2 * (\text{COS } 60^\circ - \emptyset) = \text{Total Watts}$$

Where \emptyset is the incremental angular change of 30° between V1 and I1 and V3 and I3 etc. ,

then,

$$120 * 4.1667 * \text{COS } 30^\circ + 120 * 4.1667 * \text{COS } 30^\circ + 120 * 4.1667 * (\text{COS } 60^\circ + 30^\circ) + 120 * 4.1667 * (\text{COS } 60^\circ - 30^\circ) = 1299.05 \text{ Total Watts}$$

Note: All of the calculations are very similar when testing VAR 2 1/2 Element transducers. The primary difference is replacing the COS function with the SIN function. For the example above,

$$120 * 4.1667 * \text{SIN } 30^\circ + 120 * 4.1667 * \text{SIN } 30^\circ + 120 * 4.1667 * (\text{SIN } 60^\circ + 30^\circ) + 120 * 4.1667 * (\text{SIN } 60^\circ - 30^\circ) = 1250.01 \text{ VAR's}$$

Note: All of the calculations are very similar when testing VA 2 1/2 Element transducers. The primary difference is no COS or SIN functions. For the example above,

$$120 * 4.167 + 120 * 4.167 + 120 * 4.167 = 1500.12 \text{ VA}$$

3.7.5.6 Watt/VAR 3 Element

This transducer is normally used in three-phase, four wire Wye applications, which requires 3 voltages and 3 currents to test. The three voltages and three currents are all referenced to ground. The test set will automatically select three voltage and three

current channels, **V1, V2, V3, I1, I2** and **I3**. The test will initially start at the default voltage value, that is set in the **Default Setting Screen**, for each Voltage output. Thus, for a default voltage setting of 120 volts, V1 will be set to 120 Volts at an angle of 0°, V2 will be 120 Volts at 120° lagging and V3 will be 120 Volts at 240° lagging. This assumes that the default phase angle is 0 - 360 Degrees lag, and not +/- 180 degrees. If the +/- 180 degree phase angle option is used, then V2 will be at -120° and V3 will be at +120°. I1, I2 and I3 will be in-phase with their respective voltages. When the user inputs the **MAX.** Watts value in the **Transducer Setup Screen**, the firmware can calculate the required test currents for full scale value.

The formula required to calculate Watts for 3 Element transducer is,

$$V1 * I1 * (\text{COS } \emptyset) + V2 * I2 * (\text{COS } \emptyset) + V3 * I3 * (\text{COS } \emptyset) = \text{Total Watts}$$

Where \emptyset is the incremental angular change between V1 and I1, V2 and I2, V3 and I3.

Example: The default voltage is 120.00 Volts AC, and the user inputs 1500 Watts as Max. Value. The current required for full scale output from the transducer is,

$$120 * I1 * \text{COS } 0^\circ + 120 * I2 * \text{COS } 0^\circ + 120 * I3 * \text{COS } 0^\circ = 1500 \text{ Watts}$$

$$I1 = 500 \text{ Watts} / (120 \text{ Volts} * \text{COS } 0^\circ) , \text{ or } I1 = 500 / 120$$

then I1, I2 and I3 will be 4.1667 Amperes each

Therefore, when the user inputs 1500 Watts in the **MAX.** value window, in the Test Screen the test set should automatically show a test current value for I1 of 4.167 Amperes at an angle of 0°, I2 will be 4.167 at 120° (-120°) and I3 will be 4.167 Amperes at an angle of 240° (+120°). Note that the current is rounded up to 7 in the last digit displayed.

When the test is Started, the measured voltage and current outputs are displayed and the calculated Watts is based on the measured voltage and current outputs. This is the value that gets displayed in the **Transducer Test Screen** under the **Output**. Another value of Watts gets calculated using the measured dc Volts or dc milliampere output as displayed in the **Transducer Output** section. Let us assume that in our example transducer, the output is in dc milliamperes. In this example, let 20 milliamps of dc current be equal to the full scale output of 1500 Watts. For this example, let's say that the measured output voltages are 120.01 Volts (V1, V2 and V3) and the measured output currents are 4.167, Amperes. The measured output Watts would be,

$$120.01 * 4.167 * \text{COS } 0^\circ + 120.01 * 4.167 * \text{COS } 0^\circ + 120.01 * 4.167 * \text{COS } 0^\circ$$

$$\text{or, } 500.0816 + 500.0816 + 500.0816 = 1500.24 \text{ Watts}$$

For this example, let's assume the measured output current from the transducer is 20.2 mA dc. Based on a Max. value of 20 mA equals 1500 Watts, the displayed **Watts** in the **Transducer Output** section of the **Transducer Test Screen** should read **1515.0 Watts**

The **Accuracy** displayed in the **Transducer Output** section would be equal to the following,

$$(1515 - 1500.24 / 1500.24) * 100 = \% \text{ accuracy or } 0.984 \%$$

If this were a 0.5 % transducer, then the firmware would compare the accuracy values between the Setting Screen and the Test Screen and would display **Test Failed** in the **Transducer Output** section of the test screen.

If the user adjusts the phase angle in the lagging direction by 30°, then the Watts output changes.

Using the formula,

$$V1 * I1 * (\text{COS } \emptyset) + V2 * I2 * (\text{COS } \emptyset) + V3 * I3 * (\text{COS } \emptyset) = \text{Total Watts}$$

Where \emptyset is the incremental angular change of 30° between V1 and I1, V2 and I2, and V3 and I3 etc. ,

then,

$$120.01 * 4.1666 * \text{COS } 30^\circ + 120.01 * 4.1666 * \text{COS } 30^\circ + 120.01 * 4.1666 * \text{COS } 30^\circ$$

$$\text{or, } 433.0418 + 433.0418 + 433.0418 = 1299.13 \text{ Watts}$$

Note: All of the calculations are very similar when testing VAR 3 Element transducers. The primary difference is replacing the COS function with the SIN function. For the example above,

$$120.01 * 4.1666 * \text{SIN } 30^\circ + 120.01 * 4.1666 * \text{SIN } 30^\circ + 120.01 * 4.1666 * \text{SIN } 30^\circ$$

$$\text{or, } 250.0168 + 250.0168 + 250.0168 = 750.05 \text{ VAR's}$$

Note: All of the calculations are very similar when testing VA 3 Element transducers. The primary difference is no COS or SIN functions. For the example above,

$$120.01 * 4.1666 + 120.01 * 4.1666 + 120.01 * 4.1666 = 1500.10 \text{ VA}$$

3.7.5.7 Power Factor 3 Element

The three element power factor transducer requires 3 voltages and 3 currents to test. The test set will automatically select the first three voltages and currents channels available, **V1, V2, V3** and **I1, I2, I3**. The test will initially start at the default values for voltage and current that are set in the **Default Setting Screen**. For example, 120 Volts L-N, 5 Amperes at their respective phase separations of 120 Degrees (note that for three phase Power Factor transducers the transducer requires a balanced three-phase output). The calculated Power Factors will be based on the phase separation between V1 and I1. The Power factor transducer has a range of operation that correlates to the Leading or Lagging phase angle relationship between the voltage and current inputs. Therefore, when the user selects Power Factor 3 Element, the **MIN** and **MAX** nomenclature will change to read **LEAD (+)** and **LAG (-)** power factor values. The user is required to input the **LEAD** and **LAG** power factor values into the provided spaces (normally the same values, i. e. 0.5). The power factor is the trigonometric decimal equivalent value of the COS of the angle between the V1 voltage and I1 current. For example, when the user inputs the **LEAD** and **LAG** Power Factor values in the **Transducer Setup Screen**, the firmware can calculate the required test angles for full scale values. Thus for a **LAG** Power Factor value of 0.5, the current would need to lag the voltage by 60°. The Lead and Lag phase angles require that the vector display be changed to show angles as ± 180°. If the default angle representation is 0 to 360 LAG, then the angle between the voltage and current will be considered lagging (current lags voltage). In this situation, the typical test angles may vary between 0 to 90 degrees lag and 359.9 to 270 degrees lag (90 degrees leading). This could cause some confusion to the user. By forcing the display to ± 180° simplifies the testing considerably. The test will start at unity power factor, or ±0°. Since the default angle will be 0° (zero degrees), the calculation is simple. The formula required to calculate Power Factor is,

$$\text{COS } \angle 0^\circ = 1.000 \text{ Power Factor } (V1 \angle 0^\circ, I1 \angle 0^\circ)$$

Example: The default voltage is 120.00 Volts and current is 5 Amperes AC, and the user inputs a Power Factor of ± 0.3 as **LEAD** and **LAG** Values. The angles required for full scale output from the transducer is,

$$0.3 \text{ Power Factor} = \text{COS } 72.5^\circ \text{ or,}$$

$$+ 72.5^\circ \text{ LEAD and } -72.5^\circ \text{ LAG}$$

When the test is Started, the measured voltage and current outputs are displayed and the calculated Power Factor is based on the measured phase angle between the voltage and current outputs. This is the value that gets displayed in the **Transducer Test Screen** under the **Output**.

Another value of Power Factor gets calculated using the measured dc Volts or dc milliampere output as displayed in the **Transducer Output** section. Let us assume that in our next example transducer, the output is in dc milliamperes. For this

example, let us say that ± 1 milliampere of dc current is equal to the full scale Power Factor of ± 0.5 . Therefore, the theoretical range of output from the transducer would be - 0.5 Power Factor, if the output current is -1 milliampere, to +0.5 Power Factor, if the output current is +1 milliampere. For this example, let's say that the measured output voltage is 120.0 Volts, at 0° , and the measured output current is 5.000 Amperes, at a lagging angle of $- 30^\circ$. The calculated Power Factor (displayed next to **Power Factor 3 Element**) would be,

$$\text{COS } -30^\circ = - 0.866 \text{ PF}$$

For this example, let's assume the measured output current from the transducer is - 0.489 mA dc. Based on a Lead/Lag value of ± 1 mA equals ± 0.5 PF, the scaling would be equal to

$$0.5 \text{ PF} = \text{COS } 60^\circ$$

$$1 \text{ mA} / 60^\circ \text{ or } 0.016666 \text{ mA per degree.}$$

Therefore, the displayed **PF** in the **Transducer Output** section of the **Transducer Test Screen** should read

$$- 0.489 \text{ mA} / 0.016666 \text{ mA/Degree} = - 29.35 \text{ Degrees}$$

$$\text{COS } - 29.35^\circ = - 0.871 \text{ PF}$$

Power factor transducer accuracies are stated in units of Power Factor, not in % error. Therefore, the **Accuracy** window for Power factor transducers needs to change from % error to ± 0.000 PF. For the above example the **Accuracy** displayed in the **Transducer Output** section would be equal to the following,

$$0.871 - 0.866 = + 0.005 \text{ PF}$$

If the accuracy of the transducer were a ± 0.01 PF, then the firmware would compare the accuracy values between the Setting Screen and the Test Screen and would display **PASS** in the **Transducer Output** section of the test screen.

3.7.6 Single Phase Applications

As previously described, transducers come in three-phase and single phase configurations. In the Transducer Setup Screen, the operator is required to select what type of transducer is to be tested. Once selected, the internal firmware will make certain assumptions and calculations based on the type of transducer selected. The following are detailed descriptions of the single phase AC Volts, AC Current, DC Volts, DC Current and Frequency transducers.

3.7.6.1 AC and DC Voltage Transducers

The single phase AC and DC voltage transducer requires 1 voltage output channel to test. The unit will automatically select the first voltage channel available, **V1**. The test will initially start at the default value voltage that is set in the **Default Setting Screen**. For example, 120 Volts L-N. When the user inputs the **MAX.** Volts value in the **Transducer Setup Screen**, the firmware can set the required test voltage for full scale value. Note: to power up the amplifier of some transducers, **V2** may be selected to provide the AC voltage source. Remember to select the proper output voltage for V2 (it will default to the MAX value in the setting screen). If V2 is not available, use another appropriate source.

Example: The default voltage is 120.00 Volts AC, and the user inputs 150 Volts AC as Max. Full Scale Value. When the user inputs 150 Volts in the value window, in the Test Screen the test set should automatically show a test voltage value of 135 Volts (default is at 90% of Full Scale) at an angle of 0°. Note, the DC voltage transducer is identical, except instead of 50 or 60 Hz as the default output frequency, the display changes to read DC.

When the test is Started, the measured voltage output is displayed. This is the value that gets displayed in the **Transducer Test Screen** under the **Output**. Another value of Volts gets calculated using the measured dc Volts or dc milliampere output as displayed in the **Transducer Output** section. Let us assume that in our example transducer, the output is in dc milliamperes. For this example, let us say that 1 milliampere of dc current is equal to the full scale output of 150 Volts. Therefore, the theoretical output Volts from the transducer would be 150 Volts, if the output current is 1 milliampere. For this example, the user changed the default 90% to 100%, and let's say that the measured output voltage of the unit is 150.01 Volts.

For this example, let's assume the measured output current from the transducer is 0.999 mA. Based on a Max. value of 1 mA equals 150 Watts, the displayed **AC Volts** in the **Transducer Output** section of the **Transducer Test Screen** should read $150 * 0.999 = 149.85$ Volts.

The **Accuracy** displayed in the **Transducer Output** section would be equal to the following,

$$(149.85 - 150.01 / 150.01) * 100 = \% \text{ accuracy or } -0.106 \%$$

If this were a 0.2 % transducer, then the firmware would compare the accuracy values between the Setting Screen and the Test Screen and would display **PASS** in the **Transducer Output** section of the test screen.

Note: All of the calculations are very similar when testing DC Voltage transducers

3.7.6.2 AC and DC Current Transducers

The single phase AC or DC current transducer requires 1 current to test. The software will automatically select the first current channel available, **I1**. The test will initially start at the default value current that is set in the **Default Setting Screen**. For

example, 5 Amperes. When the user inputs the **MAX.** Full Scale Current value in the **Transducer Setup Screen**, the firmware will automatically set the test current for full scale value. Note: to power up the amplifier of some transducers, **V1** may be selected to provide the AC voltage source. Remember to select the proper output voltage for V1 (it will be set to the System Default value in the setting screen).

Example: The default current is 5 Amperes AC, and the user inputs 5 Amperes AC as Max. Full Scale Value. Therefore, when the user inputs 5 Amperes in the **MAX.** value window, the test set should automatically show a test current value of 5.000 Amperes at an angle of 0°. Note, the DC current transducer is identical, except instead of 50 or 60 Hz as the default output frequency, the display changes to read DC.

When the test is Started, the measured test current output is displayed in the **Transducer Test Screen** under the **Output.** Another value of Current gets calculated using the measured dc Volts or dc milliampere output as displayed in the **Transducer Output** section. Let us assume that in our example transducer, the output is in dc milliamperes. For this example, let us say that 20 milliamperes of dc current from the transducer is equal to the full scale output of 5 Amperes. Therefore, the theoretical output Current from the transducer would be 5 Amperes, if the transducer output current is 20 milliamperes. For this example, let's say that the measured output current is 5.001.

For this example, let's say that the measured output current from the transducer is 19.9991 mA. Based on a Max. value of 20 mA equals 5 Amperes, the displayed **AC Amperes** in the **Transducer Output** section of the **Transducer Test Screen** should read **4.9997 Amperes.**

If, 20 mA = 5 Amperes or 0.25 A / 1 mA

Then, 19.99 mA * 0.25 A/mA = 4.9975 Amperes

The **Accuracy** displayed in the **Transducer Output** section would be equal to the following,

$(4.9975 - 5.001 / 5.001) * 100 = \% \text{ accuracy or } -0.0699 \%$

If this were a 0.15 % transducer, then the firmware would compare the accuracy values between the Setting Screen and the Test Screen and would display **PASS** in the **Transducer Output** section of the test screen.

Note: All of the calculations are very similar when testing DC Current transducers.

3.7.6.3 Frequency Transducers

The frequency transducer requires 1 voltage output channel to test. The software will automatically select the first voltage channel available, **V1**. The test will initially start at the default value voltage and frequency that is set in the **Default Setting Screen**. For example, 120 Volts L-N, 60.000 Hz. When the user inputs the MAX. Full Scale

Frequency value in the **Transducer Setup Screen**, the firmware will calculate the required test frequency for full scale value.

Example: The default frequency is 60.00, and the user inputs 65 Hz as Max. Value. Therefore, when the user inputs 65 Hz in the **MAX.** value window, the test set should automatically show a test frequency value of 58.50 Hz (90% of Full Scale) at the default voltage value of 120 Volts. To test at Full Scale touch the 90% window and enter 100%. Entering 100 % the test frequency will change to Full Scale or 65 Hz.

When the test is Started, the measured voltage and frequency outputs are displayed. The output frequency is the value that gets displayed in the **Transducer Test Screen** under the **Output.** Another value of Frequency gets calculated using the measured dc Volts or dc milliampere output as displayed in the **Transducer Output** section. Let us assume that in our example transducer, the output is in dc Volts. For this example, let us say that 10 DC Volts is equal to the full scale output of 65 Hz. Therefore, the theoretical output Frequency from the transducer would be 65 Hz, if the transducer output voltage is 10 Volts DC. For this example, let's say that the measured output frequency is 65.00 Hz., and the measured transducer output voltage is 10.001 Volts. The measured transducer output Frequency would be, If, $65.00 \text{ Hz} = 10 \text{ Volts DC}$

Then, $65/10 = 6.5 \text{ Hz/V}$

$V * 6.5 \text{ Hz/V} = 65.0065 \text{ Hz}$

For this example, the displayed **Hz** in the **Transducer Output** section of the **Transducer Test Screen** should read 65.000 Hz.



The **Accuracy** displayed in the **Transducer Output** section would be equal to the following,

$(65.0065 - 65.000 / 65.000) * 100 = \% \text{ accuracy or } -0.01 \%$

If this were a 0.02 % transducer, then the firmware would compare the accuracy values between the Setting Screen and the Test Screen and would display **PASS** in the **Transducer Output** section of the test screen.

3.8 Testing Differential Relays with the STVI

The STVI Differential Relay provides a quick and easy approach to testing three-phase differential relays. To test single phase differential relays use the Manual Test Screen. For testing the single phase harmonic restraint transformer differential use the Waveform selection in the Advanced Manual Test Screen, see section 3.1.10.1.4.

To access the STVI Differential Relay Test press the  Test List button next to the  Nameplate button, and then from the list press the  Differential Relay button. Press the Transformer button to open the Transformer Nameplate screen to enter information for the relay to be tested. There are two models to choose from, ANSI and IEC. You will find the

selection button at the bottom left side of the window. Press the button to toggle between ANSI and IEC transformer models. Each model will present a transformer graphic commonly used either for North American or European style transformer protection. The values entered in the Transformer Nameplate will determine what values of current and phase angle relationships get applied to the relay in the tests.

3.8.1 Transformer Nameplate

The top half is the transformer model where the user selects the Transformer Primary and Secondary winding configurations, enters the Primary and Secondary Voltages ratings, CT ratios, the transformer MVA rating, enters the single phase pickup factor, selects if there are interposing CT's (and their associated CT Multiplier values), and enables I₀ (zero sequence) elimination when applicable. In the bottom half is the relay settings, bias equation selection window and slope selection window. Once these settings are entered, the software will automatically calculate and display the base currents in primary and secondary values for each winding. Note that throughout the tests, only secondary currents are considered. Primary currents will only be shown for informational purposes. These secondary base current values will be used to compute Amp – Per Unit conversions.

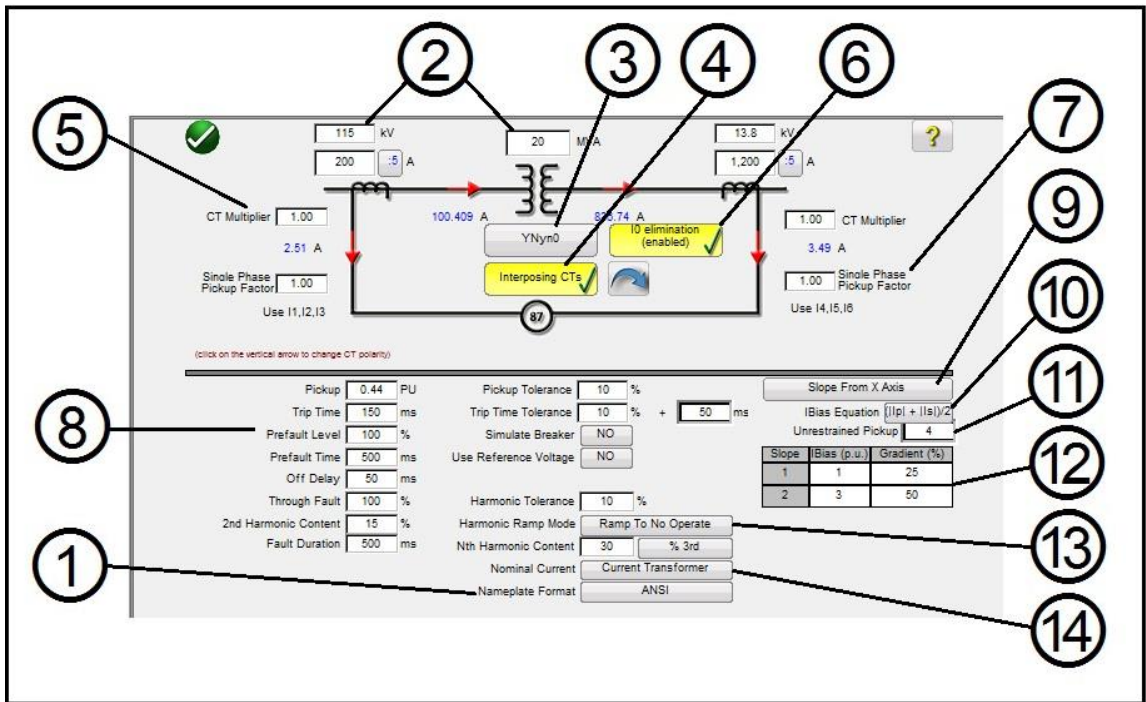

Figure 74 ANSI Transformer Nameplate Model with Interposing CT's and I₀ Elimination Selected

By entering the known values for the transformer and CT configurations the software will automatically calculate the appropriate three phase primary and secondary current values for testing the relay under test.

- ① Transformer Model Selection- Press to select the desired test model. Toggles between ANSI and IEC models.

② Enter the Transformer's Primary and Secondary voltages, MVA rating, and the Primary and Secondary Current Transformer data as specified by the relay. This includes CT ratios, CT polarities etc. If required, press or click on the vertical arrows to change CT polarity directions on both windings.

③ Transformer Configuration  Selection Button- Press or click on the transformer configuration selection button to access the available selections for the primary and secondary winding configurations. Pressing on the button will provide the Primary Winding Selection box.



Figure 75 Primary Winding Selection Box

Press or click on the appropriate button that represents the primary winding. Available selections are Y, Yn (grounded Y), D (delta), Dn (grounded Delta), Z, Zn (grounded Z), or Compensated CT's. The letter 'n' signifies a neutral / earthed star-point in which a 1.5 constant will be applied to the single phase tests. This is required for elimination of any zero sequence currents introduced when testing single phase to ground faults. The Compensated CT's selection tells the software to simulate externally connected CT's that perform all magnitude and phase compensation, therefore, no compensation, whether magnitude or phase will be applied internally by the software. After selecting the Primary Winding the Secondary Winding Selection Box will appear.



Figure 76 Secondary Winding Selection Box

Press or click on the appropriate button that represents the secondary winding. Available selections are y, yn (grounded Y), d (delta), dn (grounded Delta), z, zn (grounded Z), or compensated CT's. The Compensated CT's selection tells the software to simulate externally connected CT's that perform all magnitude and phase compensation, therefore, no compensation, whether magnitude or phase

will be applied internally by the software. After selecting the Secondary Winding the Winding Clock Reference Selection Box will appear. Depending on your selection of the primary and secondary windings will determine which clock reference screen will appear. Your choices are 1,3,5,7,9, or 11 o'clock if using a combination of Y, Delta or Z selections, or for Y – y / Delta – delta selections your choices are 0, 2, 4, 6, 8, 10, or 12 o'clock.

④ The Interposing CT's  button should be selected when interposing CT's are connected to the HV and LV windings of the relay, and are responsible for all Phase/Magnitude correction / compensation, and possible zero sequence (I₀) elimination. When selecting interposing CT's the CT Multiplier window, item ⑤, will appear for the user to enter any appropriate CT multiplier values. The phase rotation of the output currents simulating the interposing CT's can be altered by pressing the arrow button. It will toggle between clockwise and counterclockwise rotation.

 When selecting Interposing CT's, the Power System Vector Group Configuration should be selected based on this sample range of settings. For example, a Reyrolle MIB202 Numerical Bias Differential Relay with the following Interposing CT's Selection; HV (Yd1,- 30°) and LV (Yy0, 0°) requires a Vector Group Selection of Yd1, YNd1. Consult the relay manufacturer's instructional information to verify the appropriate vector group to be used for other possible Interposing CT Selections. If the manufacturer's information is not available the following guide is provided to assist the user in selecting an appropriate Transformer Vector Group.

Transformer Vector Groups and Interposing CT Selection Guide

Transformer Vector Groups	HV Interposing CT Selection	LV Interposing CT Selection
YNy0, Yy0, Ydy0, Yndy0, Yyn0, YNyn0, Ydyn0, Yndyn0, Dz0	Ydy0, 0°	Ydy0,0°
Yd1,YNd1	Yd1, -30°	Yy0,0°
Yd1, YNd1 + Grounding (Earthing) Transformer	Yd1, -30°	Ydy0,0°
YNy2, Yy2, Ydy2, Yndy2, Yyn2, YNyn2, Ydyn2, Yndyn2, Dz2	Ydy2, -60°	Ydy0,0°
Yd3,YNd3	Yd3, -90°	Yy0,0°
Yd3, YNd3 + Grounding (Earthing) Transformer	Yd3, -90°	Ydy0,0°
YNy4, Yy4, Ydy4, Yndy4, Yyn4, YNyn4, Ydyn4, Yndyn4, Dz4	Ydy4, -120°	Ydy0,0°
Yd5,YNd5	Yd5, -150°	Yy0,0°
Yd5, YNd5 + Grounding (Earthing) Transformer	Yd3, -150°	Ydy0,0°
YNy6, Yy6, Ydy6, Yndy6, Yyn6, YNyn6, Ydyn6, Yndyn6, Dz6	Ydy6, -180°	Ydy0,0°
Yd7,YNd7	Yd7, -150°	Yy0,0°
Yd7, YNd7 + Grounding (Earthing) Transformer	Yd7, -150°	Ydy0,0°
YNy8, Yy8, Ydy8, Yndy8, Yyn8, YNyn8, Ydyn8, Yndyn8, Dz8	Ydy8, 120°	Ydy0,0°
Yd9,YNd9	Yd9, 90°	Yy0,0°
Yd9, YNd9 + Grounding (Earthing) Transformer	Yd9, 90°	Ydy0,0°
YNy10, Yy10, Ydy10, Yndy10, Yyn10, YNyn10, Ydyn10, Yndyn10, Dz10	Ydy10, 60°	Ydy0,0°
Yd11,YNd11	Yd11, 30°	Yy0,0°
Yd11, YNd11 + Grounding (Earthing) Transformer	Yd11, 30°	Ydy0,0°
Dy1, Dyn1	Yy0, 0°	Yd11, 30°
Dy1, Dyn1 + Grounding (Earthing) Transformer	Ydy0, 0°	Yd11, 30°
Dy3, Dyn3	Yy0, 0°	Yd9, 90°
Dy3, Dyn3 + Grounding (Earthing) Transformer	Ydy0, 0°	Yd9, 90°
Dy5, Dyn5	Yy0, 0°	Yd7, 150°
Dy5, Dyn5 + Grounding (Earthing) Transformer	Ydy0, 0°	Yd7, 150°
Dy7, Dyn7	Yy0, 0°	Yd5, -150°
Dy7, Dyn7 + Grounding (Earthing) Transformer	Ydy0, 0°	Yd5, -150°
Dy9, Dyn9	Yy0, 0°	Yd3, -90°
Dy9, Dyn9 + Grounding (Earthing) Transformer	Ydy0, 0°	Yd3, -90°
Dy11, Dyn11	Yy0, 0°	Yd1, -30°
Dy11, Dyn11 + Grounding (Earthing) Transformer	Ydy0, 0°	Yd1, -30°

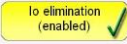
⑥ **Io (zero sequence) Elimination**  Button – Press the button to enable the zero sequence elimination feature. For relays with neutral / earthed star-point connections a 1.5 constant will be applied to the single phase tests. This is required for elimination of any zero sequence currents introduced when testing single phase to ground faults. If the relay being tested does not adopt this approach, then Io elimination should be disabled.



It should be noted that some relay manufacturers have different zero sequence correction factors for single phase faults, where the default constant of 1.5 does not apply (depending upon the transformer vector group see item ③ above for even and odd vector groups). For example, single phase faults in Siemens 7UT613 relay the even number vector groups' use 1.5, while the odd number vector groups' use 1.73. Consult the relay manufacturer's instructional information to verify the pickup factors to be used. If you use a correction factor other than 1.5, you will need to disable the Io elimination and manually enter the appropriate factor in the window provided.

⑦ **Single Phase Pickup Factor** - Once the vector groups are selected, the single phase pickup factors required to run single phase pickup tests are predetermined. If these settings do not match the relay's compensation factors, then the values should be adjusted from the input fields provided.



It should be noted that some of the relay manufacturers adopt their own pickup factors. Consult the relay manufacturer's instructional information to verify the pickup factors to be used.

⑧ **Relay and Test Settings** – The values entered will be used to perform the tests and evaluate the results. Consult the relay manufacturer's instructional information to verify the settings and tolerances.

Pickup and Pickup Tolerance: Enter the appropriate Per Unit value for the pickup value, and its associated tolerance.

Trip Time and Trip Time Tolerance: Enter the appropriate trip time of the relay and its associate tolerance.

Prefault Level: Is set in percent of Full Load Current as seen by the relay. Pick up and slope tests are performed using Pulse Ramp. This current will be applied to the relay prior to each pulse ramp increment for the Prefault Time duration.

Prefault Time: Is set in milliseconds. This will be the period of time that the Prefault currents will be applied prior to applying test values.

Off Delay: Is a time value set in milliseconds. When the relay operates, the software will extend the fault current for the off delay time entered to simulate the time delay associated with the breaker opening before the outputs go to zero.

This is used for relays that sense for breaker failure by detecting the presence of fault current after issuing a trip. Enter the opening time of the breaker associated with the transformer being protected. If the operating time is unknown use the default time of 50 milliseconds.

Through Fault: Is set in percent of Full Load Current as seen by the relay on both the primary and secondary sides of the transformer.

2nd Harmonic Content: Enter the % of second harmonic restraint set in the relay.

Fault Duration: Is set in milliseconds. This will be the time that the incremental “fault” current will be applied to the relay during the pickup, slope, and harmonic restraint tests. Set the duration time long enough for the relay to operate, or leave at the default value.

Harmonic Tolerance: Is set in percent value, used to evaluate the pickup of the 2nd harmonic restraint element.

Nth Harmonic Content: For relays with more than one harmonic restraint, enter the order of the harmonic by pressing or clicking on the harmonic selection button, then press or click in the % window to enter the percent value of the harmonic.

⑨ Slope Characteristic Selection Button: Pressing this button will provide the following selection window.

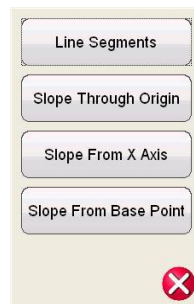

Figure 77 Slope Characteristics Selection Menu

The slope characteristics vary by manufacturer design. Four options are provided, which cover the various designs. In addition, slope characteristics are also determined by the following settings

Pickup value. This represents the lower flat line of the graph and is the minimum differential current required for the relay to trip

Unrestrained Pickup value

Slope 1, and 2 start points and gradients (start points and gradients 3 and 4 appear when selecting Line Segments)

Slope setting

I Bias equation setting

Line Segments: The Line Segments option allows for virtually any slope characteristic design with up to 4 segments. Each line segment is user defined in the Slope Line Segment window see item ⑭. When Line Segments is selected the window expands to provide up to 4 slope options. An example relay is the General Electric Model SR 745. The following example is provided as a guide to assist the user for similar type relays. Setting values vary such as knee points and % slope. Check relay settings for actual setting values.

Slope Through Origin: The line starts at the origin and rises at the Gradient % setting in the Slope Line Segment window. Slope Line 1 segment is defined by where the Slope 1 line intersects with the Minimum Pickup (represented by the lower flat line of the graph) and stops at the Slope Line 2 segment IBias (p.u.) setting in the Slope Line Segment window.

Slope From X Axis: The line starts on the X Axis at the I restraint (pu) value entered in the Line Segment window and rises at the Gradient % setting. Slope Line 1 segment is defined by where the Slope 1 line intersects with the Minimum Pickup (represented by the lower flat line of the graph) and stops at the Slope Line 2 segment IBias (p.u.) setting in the Slope Line Segment window.

Slope From Base Point: The Slope 1 line segment starts where the X Axis I restraint (pu) value entered in the Line Segment window intersects with the Minimum Pickup (represented by the lower flat line of the graph) and rises at the Gradient % setting. Slope Line 1 segment stops where at the Slope Line 2 segment IBias (p.u.) setting in the Slope Line Segment window.

⑩ IBias Equation: Pressing or clicking on the button will present the user with seven different biasing (restraint) equations to choose from. Different relay manufacturers use different methods for restraining the operation of the differential element. Consult the relay manufacturer's instructional information to verify which equation to use. The following are some example relays and associated equations.

Equation	Manufacturer
$(I_p + I_s)$	SEL 487, SEL 787, Siemens 7UT5X Series, and Siemens 7UT6X Series
$(I_p + I_s)/2$	SEL 387, SEL 587
$> I_p $ or $ I_s $	ABB RET670, GE Multilin SR 745

⑪ Unrestrained Pickup: Enter the appropriate value for the unrestrained pickup in Amps.

⑫ Slope Characteristic Line Segment Definition Table: Depending on which Slope Characteristic was chosen, see ⑨ above, the number of slope lines will vary from 2 to 4, and the IBias pickup values will vary depending on whether the slope goes through the Origin or not. See the line descriptions above for examples.

⑬ Harmonic Ramp Mode: User may select to ramp the percent of harmonic content in the fundamental up until the relay goes into restraint (Ramp To No Operate), or down to decrease the percent of harmonic until the relay drops out of restraint (Ramp To Operate).

⑭ Nominal Current in Use: Press or click on the button to toggle between Current Transformer and Protected Object to select either the calculated tap values, or the rated secondary current of the CT (use as balanced vector magnitudes during the stability test). If Protected Object is selected, W1/W2 magnitudes will be calculated from MVA, KV, and CT settings. If Current transformer is selected, W1/W2 magnitudes will be set at the rated secondary current of the CT, i.e. 1 or 5 Amps.

3.8.2 Transformer Differential Tests



When all the transformer and relay settings have been entered, press or clicks on the green check mark. The user will be taken to the first test screen, the Stabilization Test. To see a list of all the tests available, press or click on the Test List  button.



Figure 78 Test List

The user may select to perform any individual test by pressing the desired test button. After selection of the test, to execute any selected test press or click on the Blue Play . Press or

click on the Play All  button and a list will be provided; Run All (Selected) Tests, Run All Remaining (Selected) Tests, Run All Differential Tests, or Run All Remaining Differential Tests.

The following is a description of each test.

3.8.2.1 Stabilization Test

The stability test verifies the relay being tested is stable for external 3-phase faults. Settings that affect stability test are:



- Power transformer, current transformer, vector group combination settings: these settings will determine the correct magnitude and phase angles to be injected on all phases for both windings of the relay.
- Through Fault level- this sets the through fault percentage of the balanced currents applied to the relay. Setting this to 100% will inject 1x the rated current of winding1 and winding2. Setting this to 200% will inject 2x those values.
- Nominal Current in Use – The software will apply either the calculated tap values or the rated secondary current of the CT as balanced vector magnitudes during the stability test. If Protected Object is selected, W1/W2 magnitudes will be calculated from MVA, KV, and CT settings. If Current transformer is selected, W1/W2 magnitudes will be set the rated secondary current of the CT i.e. 1 or 5.

1. Connect the appropriate output terminal(s) for the selected channel(s) to be used.
2. Connect the desired Binary Input terminal to sense the relay trip contacts. Press the selected Binary Input. If the Binary Input is already set to **Use as Trip (enabled)**, select for the appropriate sensing Normally Open, Normally Closed, Voltage Applied, or Voltage Removed.
3. Press or click on the Blue Play  button to run stability test. This will inject the balanced 3 phase currents based upon the Transformer and Vector Group settings. For a stable condition, the relay is not expected to trip. Enter the metered values from the relay and observe that they correspond to the injected values. Press or click on the Finish / Abort button (if the injected values do not correspond, press or click on Simulate Contact or Force Failure buttons). Note that the relay might not trip if the differential function has been turned off, or the injected values are not sufficient enough to produce the minimum differential current (this is also considered as a failed test even if the relay does not trip).

If the relay trips instantaneously, verify nameplate settings correspond to relay settings, verify connections are correct etc. To View the test result, press the Add to Reports  button.

3.8.2.2 Timing Test

Timing test verifies the relay being tested operates at the expected trip time for internal three phase faults or internal phase to earth faults. Settings that affect timing test are:

- Power transformer, current transformer, vector group combination settings: these settings will determine the correct magnitude and phase angles to be injected on all phases for both windings of the relay.
 - Trip time – This is the expected trip time for the relay to operate. This value should be verified from the relay. If the relay does not trip, the software will inject the fault vector for 2* the expected trip time and then automatically stop the test.
 - Prefault Level / Prefault Duration – these values configure the prefault vector that will be injected before fault vectors are applied.
1. Connect the appropriate output terminal(s) for the selected channel(s) to be used.
 2. Connect the desired Binary Input terminal to sense the relay trip contacts. Press the selected Binary Input. If the Binary Input is already set to **Use as Trip (enabled)**, select for the appropriate sensing Normally Open, Normally Closed, Voltage Applied, or Voltage Removed.
 3. Press or click on the Blue Play  button to run the Timing Tests. For the single phase tests, the fault vector will be applied on the phase being tested, while balanced (prefault) current vectors will be applied across the other phases. For the three phase tests, the test set will inject the fault vectors across all 6 phases.
 4. To View the test result, press the Add to Reports  button.

3.8.2.3 Pickup Test



The pickup test verifies the minimum operate current of the diff relay. The test is performed using a Pulse Ramp which applies the appropriate prefault value before the Ramping begins. The Pulse Ramp will return to the Prefault condition between each increment. Based on the settings of the relay, the Pulse Ramp begins at 85% of the expected pickup value, applying the prefault and fault vectors appropriately until the relay trips. If this trip signal is detected within the tolerance ranges of the relay, a pass message will be displayed. If on first injection a trip signal is detected the ramp will return to 50% of the expected pickup value and run from there. If a trip signal is detected at 50% then a failure message is displayed.

Considerations to make before running the pickup test

- During the single phase test, the selected vector group would have defined the single phase pickup factors that will be used for the test. It is imperative that these values match the values that are specified by the relay manufactures' manual (Relay manufacturers may sometime defer from the Differential standard single phase pickup factors).
- During the single phase test, if the selected vector group has an earthed star-point on either or both of the windings, it is essential to select if the relay compensates for zero sequence currents introduced by the phase to ground fault. When zero sequence (I₀ elimination) is enabled a 1.5 factor is introduced to eliminate any zero sequence currents. If the relay does not perform zero sequence elimination this factor is not needed and should be disabled.
- During the three phase test, the selected vector group would have defined the phase compensation values across all 6 phases. It is imperative that the vector group selected matches the vector group on the relay settings.

Settings that affect Pickup test

- Power transformer, current transformer, and vector group combination settings determine the tap current which will be used to convert the Per Unit value to actual Amps that is injected into the relay. The vector group settings will determine the single phase pick up factors, which adjusts the amp value injected to compensate the vector magnitudes based on a wye, delta or zigzag connected transformer.
- Pickup – This is minimum pickup Per Unit value required for the relay to operate. The search routine will begin from 85% of the minimum pickup and pulse ramp until it finds the operating point. If this value is not entered correctly in the settings screen, the search routine will be performed incorrectly.
- Prefault Level / Time – these values configure the prefault vector that will be injected before any fault vectors.
- Fault Duration – this setting defines the number of milliseconds the fault vector will be applied. Make sure that this value is slightly more than the operating time of the relay to insure that the test set will see the trip contacts pickup.

1. Connect the appropriate output terminal(s) for the selected channel(s) to be used.
2. Connect the desired Binary Input terminal to sense the relay trip contacts. Press the selected Binary Input. If the Binary Input is already set to **Use as Trip (enabled)**, select for the appropriate sensing Normally Open, Normally Closed, Voltage Applied, or Voltage Removed.
3. Press or click on the Blue Play  button to run the Pickup Test. A menu list will be presented to the user to select which winding to test. For the single phase tests, the fault vector will be applied on the phase being tested, while balanced (prefault) current vectors will be applied across the other phases. For the three phase tests, the test set will inject the fault vectors across all 6 phases.
4. To View the test result, press the Add to Reports  button.

3.8.2.4 Slope Test

The slope test verifies the bias differential characteristic of the relay. For each value of the bias (restraint) value selected, a search-line routine finds the value of the pickup point necessary for the relay to operate. These values are plotted on the characteristic graph.

Settings that affect the Slope Test

- Power transformer, current transformer, vector group combination settings: these settings will determine the tap current which will be used to convert the PU value to actual Amps that is injected into the relay. The vector group settings will determine the phase compensation to be applied during the 3-phase fault test. The phase angles will be adjusted automatically during the search routine based on the clock group selected.

- I Bias Equation – the current magnitudes injected to the relay are calculated based on the bias formula the relay uses. The primary (I1) and secondary (I2) currents are calculated from Id and Ir simultaneously. Consequently, it is imperative the I Bias Equation selection matches the equation specified by the relay being tested.
- Slope setting – This defines the way the characteristic is drawn. It is important to select the appropriate slope settings in order to draw the appropriate theoretical characteristic for the relay.
- Prefault Level / Time – these values configure the prefault vector that will be injected before any fault vectors.
- Fault Duration – this setting defines the number of cycles the fault vector will be applied for.

Creating Search Lines

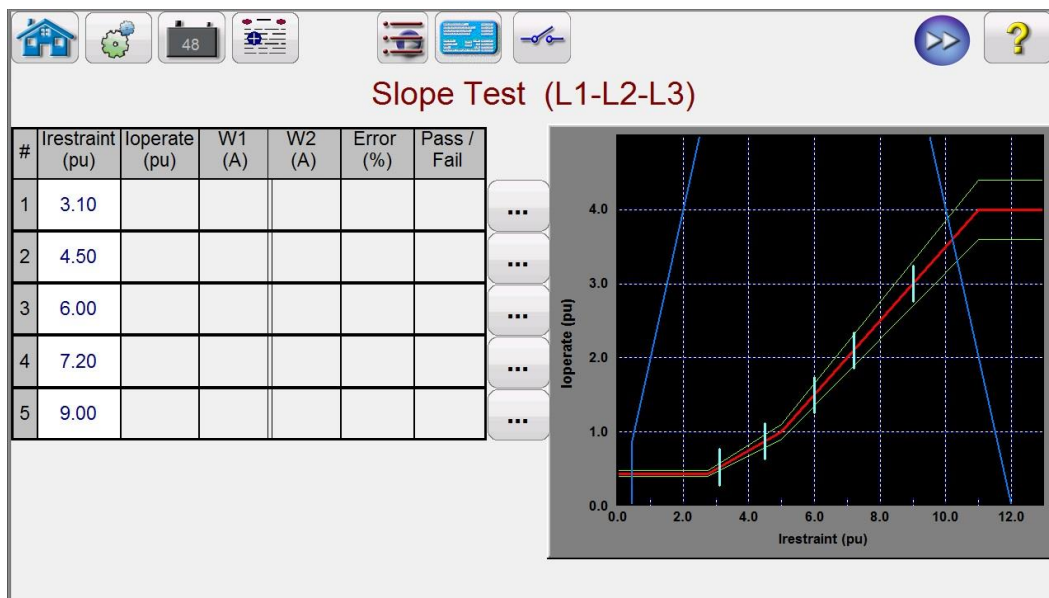

Upon selecting the Slope Test the user will be taken to the Slope Test Screen, which includes the graphic display of the relay Slope Characteristic. Click in the characteristic window to create a search line associated with the slope characteristic. The following is an example with four test lines drawn.



Note the blue limit lines in the above figure. This Slope Test Screen is based upon using a SMRT410 with 6 current channels capable of providing up to 60 Amps each. Therefore, there is virtually no limit regarding the operating and restraint currents. If using a SMRT36, with the voltage channels converted to currents, a blue limit line will appear from the right side of the graphic which may cross the upper portion of the slope characteristic depending upon the relay settings. The second blue line indicates the limits regarding the maximum output current from the convertible channels, and shows area of the slope characteristic that can be tested.

If you mistakenly enter a test line and want to delete it press or click on the Run Edit  button associated with the selected test #. The user will see a list of actions that can be done. One of the

actions is Delete. Pressing the Delete button, the software will ask you to confirm that you want to delete the test(s).

1. Run all tests by either pressing or clicking on the Blue Play  button. To run individual tests press or click on the Run Edit  button for the individual tests. When the test starts a red arrow test line will start ramping up the search line. Once the arrow enters the acceptable tolerance line the arrow will change color to green. When the relay operates, if the test point is within the acceptable min/max tolerance lines a green dot will appear, the % error will be displayed in the test table along with Pass declaration, and the test will move onto the next test line. If the test point is outside the acceptable tolerance a red X will appear, the % error will be displayed in the test table with the Fail declaration.
2. To View the test result, press the Add to Reports  button.

3.8.2.5 Harmonic Block Test

The harmonic block test verifies the proper operation of the harmonic restraint element of the relay. The test is based upon the 2nd Harmonic Content (and/or Nth Harmonic Content) and Harmonic Tolerance entered in the settings. In the test screen the user can select individual phases for test as well as three phase test, either Primary or Secondary side of the transformer.

The Harmonic Block test is performed by applying a fundamental current equal to the Pickup setting, which will cause the relay to operate and close the trip contacts. The harmonic content will slowly be ramped up increasing the percent of harmonic until the relay goes into restraint. At that point the percent of harmonic is recorded.

Settings that affect the Harmonic Block test



- Power transformer, current transformer, and vector group combination settings determine the tap current which will be used to convert the Per Unit value to actual Amps that is injected into the relay. This will be the fundamental current applied at the start of the test.
- Prefault Level / Time – these values configure the prefault vector that will be injected before any fault vectors.
- Fault Duration – this setting defines the number of milliseconds the fault vector will be applied. Make sure that this value is slightly more than the operating time of the relay to insure that the test set will see the trip contacts pickup.
- Harmonic Content – The search routine will begin from 85% of the expected restraint value and ramp the harmonic content up until it finds the restraint point. If this value is not entered correctly in the settings screen, the search routine will be performed incorrectly.
- Harmonic Tolerance – This value is used to determine Pass/Fail.

1. Connect the appropriate output terminal(s) for the selected channel(s) to be used.
2. Connect the desired Binary Input terminal to sense the relay trip contacts. Press the selected Binary Input. If the Binary Input is already set to **Use as Trip (enabled)**, select for the appropriate sensing Normally Open, Normally Closed, Voltage Applied, or Voltage Removed.



Application Note: The Prefault values will be applied prior to applying the harmonic block test. Make sure that all three phase outputs are connected to the relay under test. When the ramp

starts the PU Tap current will be applied, thus the relay will close the trip contacts. Therefore, set the binary input to sense Normally Closed (Trip) contacts to Open (Restraint). If using wetted contacts set the binary input to sense Voltage Removed.

3. Press or click on the Blue Play  button to run the Harmonic Block Test. A menu list will be presented to the user to select which winding to test. For the single phase tests, the test current will be applied on the phase being tested, while zero current will be applied across the other two phases. For the three phase tests, the test set will inject the fault vectors across all 3 phases on the desired Winding (Primary or Secondary).
4. To View the test result, press the Add to Reports  button.

3.8.2.6 Harmonic Shot Test

The harmonic shot test is a GO/ NO GO test to quickly verify the proper operation of the harmonic restraint element of the relay. The test is based upon the 2nd Harmonic Content (and/or Nth Harmonic Content) and Harmonic Tolerance entered in the settings. In the test screen the user can select individual phases for test as well as three phase test, either Primary or Secondary side of the transformer.

The Harmonic Shot test is performed by applying a 5% above the harmonic restraint pickup value to see if the relay will restrain, and then apply 5% below the harmonic restraint pickup value to see if the relay operates.



Settings that affect the Harmonic Shot test

- Power transformer, current transformer, and vector group combination settings determine the tap current which will be used to convert the Per Unit value to actual Amps that is injected into the relay. This will be the fundamental current applied at the start of the test.
- Prefault Level / Time – these values configure the prefault vector that will be injected before any fault vectors.
- Fault Duration – this setting defines the number of milliseconds the fault vector will be applied. Make sure that this value is slightly more than the operating time of the relay to insure that the test set will see the trip contacts pickup.
- Harmonic Content – If this value is not entered correctly in the settings screen, the test routine will be performed incorrectly.

1. Connect the appropriate output terminal(s) for the selected channel(s) to be used.
2. Connect the desired Binary Input terminal to sense the relay trip contacts. Press the selected Binary Input. If the Binary Input is already set to **Use as Trip (enabled)**, select for the appropriate sensing Normally Open, Normally Closed, Voltage Applied, or Voltage Removed.



Application Note: The Prefault values will be applied prior to applying the harmonic block test. Make sure that all three phase outputs are connected to the relay under test. Set the binary input to sense Normally Open contacts to be Open (Restrain at +5%) and Close (Trip at – 5%).

3. Press or click on the Blue Play  button to run the Harmonic Shot Test. A menu list will be presented to the user to select which winding to test. For the single phase tests, the test current will be applied on the phase being tested, while zero current will be applied across the other two phases. For the three phase tests, the test set will inject the fault vectors across all 3 phases on the desired Winding (Primary or Secondary).
4. To View the test result, press the Add to Reports  button.

4.0 Warranty Statement

Megger warrants the product is free of defects in material and workmanship for a period of one (1) year from date of shipment. This warranty is non-transferable. This warranty is limited and shall not apply to equipment that has damage, or cause of defect, due to accident, negligence, and improper operation, faulty installation by the purchaser, or improper service or repair by any person, company or corporation not authorized by Megger. Megger will, at its' option, either repair or replace those parts and/or materials it deems to be defective.

The warranty is in lieu of all other warranties, either expressed or implied on the part of Megger and in no event shall Megger be liable for the consequential damages due to the breach thereof.

5.0 Service Data

5.1 Preventive Maintenance

The unit utilizes surface mount technology (SMT) and other components which require little or no service except for routine cleaning, etc. The unit should be serviced in a clean atmosphere away from energized electrical circuits.

5.1.1 Examine the unit every six months for:

Dust and Dirt	To clean the unit, never use spray liquids or industrial cleaners. Some cleaning solvents can damage electrical components, and should never be used. Use a lightly damp cloth (not dripping wet) to wipe off the unit. Remove dust with dry, low pressure, compressed air.
Moisture	Remove moisture as much as possible by putting the test set in a warm, dry environment.

5.1.2 Upgrading STVI Software

Upgrade via Megger Website

To download the newest STVI software from the Megger website,

1. Get the serial number of your unit.
2. Go to WWW.Megger.com
3. **Log In.** If you have not registered before you will need to do so first.
4. Go to **Software Downloads**
5. Click on **STVI**
6. You will see instructions to enter the serial number of the STVI unit, and then click on **Continue.** The serial number is 12 digits long. Make sure you enter all 12 digits. There will be two versions of the software. One is for your PC and one is for the STVI. For the STVI unit go to the **STVI software for STVI Installation or Upgrade** and press on the Click Here link. The software will be downloaded onto your PC as a zip file. Unzip the file, **Select All** files, and **Copy** to a USB memory stick, or create a file on your PC for storage to unzip or extract to a file.

Upgrade via Compact Disk

Where internet access may not be available or blocked on your computer, Megger can provide a

CD with the latest version of software on it. Contact your local Megger representative to order a copy of the firmware.

How To Download STVI Software into STVI

USB Memory Stick: With the STVI powered up, insert the USB memory stick into the USB port on top of the STVI. If the Windows “Removable Disk (E)” Explorer screen appears, press the Cancel button, and then go to the STVI Configuration Screen and press the Update Firmware button. Press the “STVI Firmware” button. A window will appear stating that there is a software upgrade available and will ask if you want to execute the upgrade. Press Yes and the unit will automatically upgrade the software. When complete, power down the STVI by disconnecting the Ethernet cable. Wait about 5 to 10 seconds and reconnect the cable. Observe the STVI display screen. When the basic test screen appears, press the Configuration button, then press the Display Versions button and verify the version of the software upgrade.

5.2 Service and Repair Instructions

Basic troubleshooting information has been provided to guide the technician to the possible source of a problem.

Since the STVI uses Surface Mount Technology, repairs of the individual printed circuit boards are beyond the scope of the basic troubleshooting guide, and should be referred to the Service Department at Megger or handled through the Megger Representative.

 If the unit is still within the original warranty period, or limited warranty period following factory servicing, **the factory must be contacted before attempting any repairs or the warranty will be void.**

5.2.1 Basic Troubleshooting

The troubleshooting information relies on the technician to have a good understanding of the operation of the unit. The technician should contact the factory should they have any questions regarding the operation of the unit. Provide the Megger the serial number of the STVI when making inquiries.



WARNING It is necessary to energize the SMRT33/36 to properly troubleshoot the STVI. The technician must take all applicable safety precautions for working with the possible energized outputs of the SMRT33/36.

NOTES

Before suspecting a failure in the STVI review the Description of Controls and Theory of Operation sections to ensure that the problem is not a result of operating error.

Common causes of malfunctions, other than improper operation, are bad Ethernet cable or cable connectors, or incorrect power input (voltage above or below specified limits).

 **NOTE:** Under no circumstance should the technician take the STVI apart without following proper ESD protection and handling procedures. Failure to do so, will damage sensitive parts.

5.2.1.1 Power Input

Input voltage affects the whole unit, including the 48 Volts DC to the STVI from the PoE port, and may or may not cause permanent damage if voltage is incorrect. These problems can often be corrected by simply using a better source of input power. See unit front panel for input voltage rating.

Some symptoms are as follows:

1. Low voltage: Erratic operation, no display, or a dim display.
2. High voltage: Circuit breaker operation on SMRT unit, power supply failure.
 - a. For SMRT1 and MPRT units, the STVI uses the PoE power supply. It has an LED that lights up under normal operation. If not lit, then the PoE power supply has failed and needs to be replaced, PN: 90001-736.
 - b. For SMRT33/36, the internal power supply needs to be repaired or replaced, contact the factory for further instructions.

5.2.1.2 Ethernet Cable

Basic troubleshooting of the Ethernet communication cable as follows,

1. No power: Check power source and line cord. If the SMRT33/36 powers up, but the STVI display does light up, check the cable and cable connectors. Typical problem is usually a broken conductor or cracked cable connector. Replace cable to see if this resolves issue.
2. Erratic Manual Control / Missing Channels on STVI Display
 - A. Communication cable is not properly connected, thus cannot receive proper commands.
 - B. Internal problem with communications inside the SMRT33/36, see SMRT33/36 in Addendum A. Communication cables inside the SMRT33/36 unit may require reseating.

 Contact the factory for a Repair Authorization Number and return instructions if service is required. A Repair Authorization (RA) number will be assigned for proper handling of the unit when it arrives at the factory. Any non-warranty repair cost incurred for the repair or replacement of parts and/or materials shall be the responsibility of the purchaser.

Provide the factory with model number, Unit serial number, nature of the problem or service required, return address, your name, and how to contact you should the factory need to discuss the service request.

You may need to provide a purchase order number, cost limit, billing, and return shipping instructions. If an estimate is requested, provide the name and contact information.

6.0 Preparation for Reshipment

 Save the original shipping container for future use. The shipping container is designed to withstand the rigors of shipping via a common commercial carrier.

Pack the equipment appropriately to prevent damage during shipment. If a reusable container is utilized, the unit will be returned in the same shipping container if it is in suitable condition.

Add the Return Authorization Number to the address label of the shipping container for proper identification and quicker handling.

 NOTE: Ship the equipment without nonessential items such as test leads, etc. These items are not needed by the factory to perform service.

Megger[®]

Addendum A



*Standard enclosure model shown











Model SMRT1 **Megger Single Phase Relay Tester**

SAFETY PRECAUTIONS

WARNING:

VOLTAGES GENERATED BY THIS INSTRUMENT CAN BE HAZARDOUS

This instrument has been designed for operator safety; however, no design can completely protect against incorrect use. Electrical circuits are dangerous and can be lethal when lack of caution and poor safety practices are used. There are several standard safety precautions that should be taken by the operator. Where applicable, IEC safety markings have been placed on the instrument to notify the operator to refer to the user manual for instructions on correct use or safety related topics. Refer to the following table of symbols and definitions.

Symbol	Description
	Direct Current
	Alternating Current
	Both direct and alternating current
	Earth (ground) Terminal. There is a common chassis ground terminal located on the front panel (see Front panel under Description of Controls).
	Protective Conductor Terminal
	Frame or Chassis Terminal
	On (Supply)
	Off (Supply)
	Caution, risk of electric shock
	Caution (refer to accompanying documents)

 **WARNING:** Under no circumstances should the operator or technician attempt to open or service this instrument while connected to a power source. Lethal voltages are present and may cause serious injury or death!

SAFETY PRECAUTIONS (Continued)

The following are some specific safety related items associated with the SMRT test system.

Read and understand all safety precautions and operation instructions before attempting to use this unit.

The purpose of this equipment is limited to use as described in this instruction manual. Should a situation arise that is not covered in the general or specific safety precaution please contact Megger regional representative or Megger, Dallas Texas.

Safety is the responsibility of the user. Misuse of this equipment can be extremely dangerous.

Always start with the power OFF, before connecting the power cord. Make sure outputs are off before attempting to make test connections.

Never connect the test set to energized equipment.

Always use properly insulated test leads. The optional test leads are rated for the continuous output ratings of the test system, and should be properly used and cared for. DO NOT use cracked or broken test leads.

Always turn the test system off before disconnecting the power cord.

DO NOT attempt to use the unit without a safety ground connected.

DO NOT attempt to use the unit if the power cord ground prong is broken or missing.

DO NOT use the test set in an explosive atmosphere.

The instrument must only be used by suitably trained and competent persons.

Observe all safety warnings marked on the equipment.

For safety related or other important topics, like the statement below, will be notated with the adjoined symbol. Read the topic carefully as it may relate either to the safe operation of the test system or the safety of the operator.



Under no circumstances should the operator put their hand or tools inside the test system chassis area with the test system connected to a power source. Lethal voltages are present and may cause serious injury or death!

1.0 Operation

The unit's design is a "modular" concept. All inputs and outputs are clearly marked and logically grouped so continual reference to the instruction manual should not be necessary once the operator is acquainted with the test system.

1.1 General Description

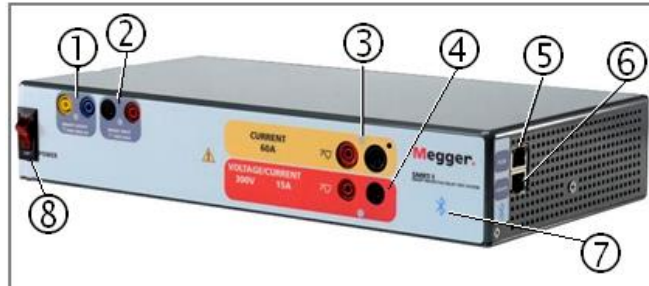

Figure 79 SMRT1 (Standard unit pictured)

1.1.1 Front Panel

1. **Binary Output** – the Binary Output can be configured as Normally Open or Normally Closed contacts providing logic to the device under test. The Binary Output can switch up to 300 VAC or 250 VDC with 8 Amp continuous. The programmable wait duration is from 1 millisecond to 10,000 milliseconds.
2. **Binary Input** – The Binary Input will accept a voltage range of 5 to 300 VAC, or 5 to 250 VDC, or dry Normally Open / Normally Closed contacts.
3. **Current Channel Output** – For more details on the VIGEN output capabilities see section 1.4.
4. **Voltage Channel Output** – For more details on the VIGEN output capabilities see section 1.4.
5. **PC/IN Ethernet Port** is a 10/100BaseTX port, and is the primary PC connection port. This port supports MDI/MDI-X auto cross over configuration, which means both standard and “crossover” Ethernet cables may be used. This port provides the optimal method for downloading EMTP files, DFR streaming, and updating the unit’s firmware as required. The SMRT comes standard with a crossover cable. This port may also be used for multiple unit operation, the unit providing the 61850/OUT link is providing the master phase reference to all units “downstream”.
6. **61850 / OUT Ethernet Port** is a 10/100BaseTX port, and is primarily used to interconnect multiple SMRT units together for synchronous multi-unit operation. With the PC connected to the PC/ IN Port, the SMRT1 61850 / OUT port may be connected to another SMRT unit PC / IN port “downstream” providing phase synchronization through the Ethernet port. This port may also be used to provide access to the substation IEC 61850 network to receive and send GOSSE messages.
7. **Bluetooth** wireless port – this port is optional, and provides a wireless interface control with a PC. It also provides isolation between the IEC 61850 bus and the user PC.
8. **POWER ON/OFF Switch** – used to switch unit on and off. The switch illuminates when power is on.

1.1.2 Side Panel:

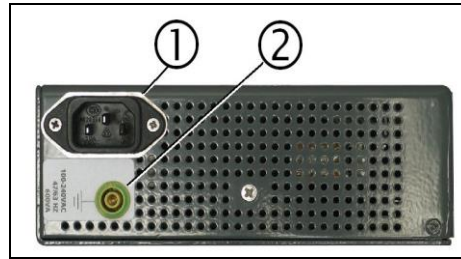

Figure 80 SMRT1 Power Input Panel

1. **Incoming Power / Line Cord** – the input line cord, ground terminal, are mounted on the side panel of the test set.

Input Line Cord

The test set is equipped with a line cord, which connects to the male connector on the side panel. Verify the input voltage before connecting the line cord to the power source.



NOTE: The unit can be powered from an input source with a rating of 100 VAC to 240 VAC, 50/60 Hz. The unit automatically adjusts to the available power if it is within the specified range.

2. **Earth Ground Jack** – use this terminal to connect chassis ground to earth ground.

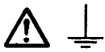

A chassis ground (earth) point on the front panel is provided as an additional safety ground.

1.1.3 Rack Mount Enclosure Rear Panel:



Figure 81 SMRT1 Rack Mount Back Panel Power Input

1. **Incoming Power / Line Cord** – the input line cord, ground terminal, are mounted on the back panel of the test set.

Input Line Cord

The test set is equipped with a line cord; see the accessory kit, which connects to the male plug on the back panel. Verify the input voltage before connecting the line cord to the power source.



NOTE: The unit can be powered from an input source with a rating of 100 VAC to 240 VAC. The unit automatically adjusts to the available power if it is within the specified range.

2. **Earth Ground Jack** – use this terminal to connect chassis ground to earth ground.



A chassis ground (earth) point on the back panel is provided as an additional safety ground.



Figure 82 SMRT1 Rack Mount Back Panel Signal and Communication Ports

1. **IN** Ethernet Port is a 10/100BaseTX port, and is the primary PC connection port. This port supports MDI/MDI-X auto cross over configuration, which means both standard and “crossover” Ethernet cables may be used. This port provides the optimal method for downloading EMTP files, DFR streaming, and updating the unit’s firmware as required. The SMRT comes standard with a crossover cable. This port may also be used for multiple unit operation, the unit providing the OUT link is providing the master phase reference to all units “downstream”.
2. **OUT** Ethernet Port is a 10/100BaseTX port, and is primarily used to interconnect multiple SMRT units together for synchronous multi-unit operation. With the PC connected to the IN Port, the SMRT1 OUT port may be connected to another SMRT unit IN port “downstream” providing phase synchronization through the Ethernet port. This port may also be used to provide access to the substation IEC 61850 network to receive and send GOOSE messages.
3. **External Amplifier BNC Inputs** – There are two BNC connectors labeled I and V/I on the back panel. These connectors are used to amplify an external analog signal using the SMRT amplifiers. Application of ± 10 Volts Peak will provide Full Scale output (Range dependent) from the selected output.



CAUTION: DO NOT APPLY MORE THAN ± 10 VOLTS PEAK TO THE EXT INPUT TERMINALS. APPLICATION OF MORE THAN 10 VOLTS PEAK MAY DAMAGE THE AMPLIFIER.

1.2 Input Power

The input voltage may be from 100 to 240 VAC, 50/60 Hertz, 600VA. The input is protected by an ON/OFF switch / circuit breaker.

1.2.1. Input Power Cord

Depending on the country, the power cord can come with a NEMA 5-15 male connector, a CEE 7/7 Schuko two prong connector, a UK power cord, or with International Color Coded pig-tail wires (light blue, brown and green with yellow stripe) with the insulation jacket stripped ready for installation of the appropriate male connector.

Model SMRT1 10NXXXAXXX comes with a North American power cord (part number 620000).

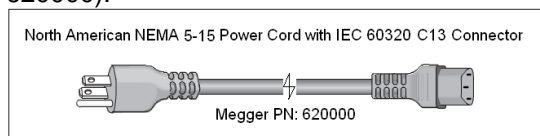

Model SMRT1 10NXXXEXXX comes with a Continental Europe power cord (part number 50425).

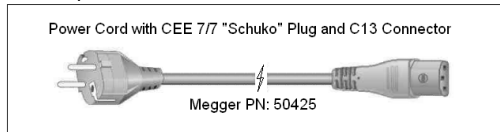

Model SMRT1 10NXXXIXXX comes with an International Color Code power cord. The cord, part number 15065, is ready for wiring to the appropriate plug (depending on country). The following colors apply, Brown = Line, Blue = Neutral and Green/Yellow = Ground.

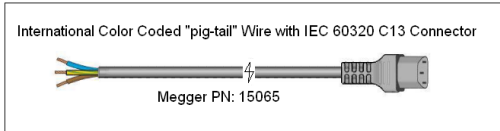

Model SMRT1 10NXXXUXXX comes with a UK power cord (part number 90002-989).

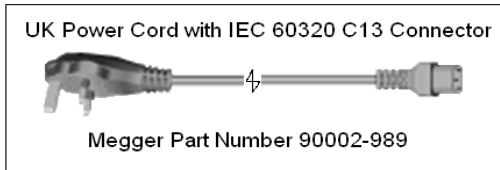

1.3 Voltage - Current Generators

Voltage and Current is noted by the red and yellow surrounding each output channel. The voltage channel is denoted by the red color. The current channel is denoted by the yellow color. All outputs are independent from sudden changes in mains voltage and frequency, and are regulated so changes in load impedance do not affect the output. All SMRT1 amplifier outputs are isolated or floating.

1.3.1. Convertible Voltage/Current Amplifier

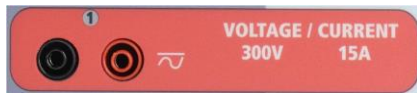

The SMRT PowerV™ voltage amplifier provides a flat power curve from 30 to 150 Volts in the 150V range to permit testing of high current applications such as panel testing.

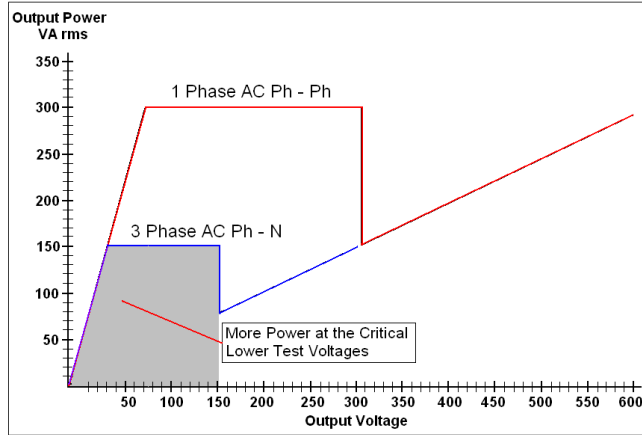

Figure 83 Voltage Amplifier Power Curve

Voltage Range

Power / Current (Max)

30.00V 150VA @ 5.0A
 150.00V 150VA Constant Output Power from 30 to 150 Volts
 300.00V 150VA @ 0.5A

Voltage Amplifier in Current Mode:

The voltage amplifier is convertible to a current source with the following output capability. Output power ratings are specified in rms values and peak power ratings.

Output Current	Power	Max V	Duty Cycle
5 Amperes	150 VA (212 peak)	30.0 Vrms	Continuous
15 Amperes	120 VA	8.0 Vrms	90 Cycles

The convertible channel in conjunction with the main current channel provides 2 currents for testing current differential relays one phase at a time.

! The voltage amplifier output is protected from short circuits and thermally protected against prolonged overloads. In case of a short circuit or a thermal overload, the amplifier will automatically turn off, and if the STVI is connected a message to the user will be displayed indicating which condition exists. If AVTS software is used, a similar message will appear.

1.3.2. Current Amplifier



The SMRT current amplifier delivers maximum compliance voltage to the load constantly during the test, and range changing is done automatically, on-the-fly, under load. This insures better test results, saves time by not having to turn the outputs off to change output taps or ranges, and unlike single range current amplifiers insures a higher compliance voltage at lower test currents. Constant power output in many cases eliminates the need to parallel or series current channels together to test high burden relays.

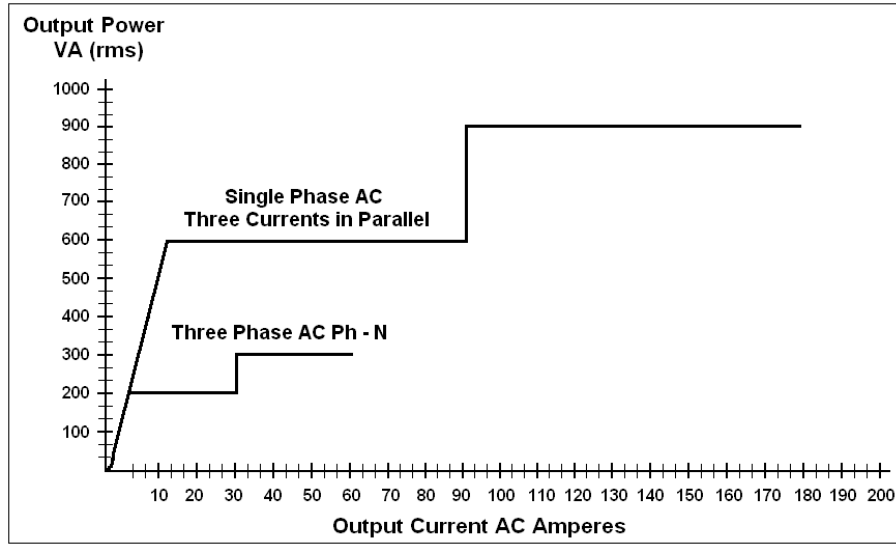

Figure 84 Current Amplifier Power Curves

The following are typical output current and associated available compliance voltage values. The output current and power ratings are specified in AC rms values and peak power ratings. Specified duty cycles are based upon typical room ambient.

Output Current	Power	Max V / Duty Cycle
1 Ampere	15 VA	15.0 Vrms Continuous
4 Amperes	200 VA (282 peak)	50.0 Vrms Continuous
15 Amperes	200 VA (282 peak)	13.4 Vrms Continuous
30 Amperes	200 VA (282 peak)	6.67 Vrms Continuous
60 Amperes	300 VA (424 peak)	5.00 Vrms 90 Cycles
DC 200 Watts		

! The current amplifier output is protected from open circuits and thermally protected against prolonged overloads. In case of an open circuit or a thermal overload, the amplifier will automatically turn off, and if the STVI is connected a message to the user will be displayed indicating which condition exists. If AVTS software is used, a similar message will appear.

1.4 Binary Input and Output



Figure 85 SMRT1 Binary Input and Output

The SMRT1 Binary Input and Output are clearly marked and logically grouped. The Binary Input is used to monitor relay trip contacts for performing pickup and dropout tests as well as for performing timing functions. The Binary Output is used to simulate normally open / normally closed contacts for testing breaker failure schemes, or similar power system operations. In addition they may also be used to switches AC/DC voltages and currents.

1.4.1 Binary Input

The binary input is specifically designed to measure high speed operation of electro-mechanical, solid-state and microprocessor-based protection relays. The binary Input defaults to Monitor Mode, Contact change of state, latched OFF. If using the STVI or STVI software to change a binary input from Contact change of state to Voltage Applied / Removed click on or touch the Input Type window and a sine wave will appear where the Contact icon was indicating. The input is now set for voltage sensing. To change the binary input from Monitor mode to Timer Mode, click on or touch the Use as Monitor button and the display window will change to show Use as Trip, Latched, meaning the binary input is now set to stop the timer upon sensing the first contact closure (if the Input Type is set for contact) or upon sensing voltage if the Input Type is set to Voltage Sensing.

1.4.1.1 Start, Stop, and Monitor Gate

In the SMRT1 the independent, programmable gate circuit permits simple selection of the desired mode for timing or contact monitoring operation.

To monitor operation of the contacts or trip SCR in the device under test, a light is provided for the gate. The gate circuit is isolated for voltage-sensing and can monitor solid-state logic signals. The light will illuminate once contacts close or voltage is applied to the gate.

1.4.1.1.1 Dry Contacts Open

Timer stops or a continuity indicator goes out at the opening of normally closed contacts, or when conduction through a semiconductor device, such as a triac or a transistor, is interrupted.

1.4.1.1.2 Dry Contacts Close

Timer stops or a continuity indicator glows at the closing of the normally open contacts, or upon conduction through a semiconductor device such as a triac or a transistor.

1.4.1.1.3 Application or Removal of AC or DC voltage

The continuity indicator will glow (application) or darkens (removal) upon the application or removal of either an AC or DC voltage. A higher threshold voltage helps to eliminate false triggers due to a noisy source. Lower thresholds allow stopping the timer from TTL voltage signals. The allowable voltage applied is 5 to 300 Volts AC or 5 to 300 Volts DC, current limiting resistors provide protection.

1.4.1.1.4 The Timer can be started when turning on any selected generators.

1.4.1.1.5 The Timer can be started simultaneously with a change in Frequency, Phase Angle, or Amplitude. Also, it can be started simultaneously with a Voltage or Current waveform step.

1.4.2 Binary Output

Binary Output is rated for 300 V at 8 Amps and a maximum of 2000 VA breaking capacity (80 watts DC), with a response time of less than 10ms. The Binary Output can be configured as normally open or normally closed contacts providing logic to the device under test. The programmable wait duration is from 1 millisecond to 10,000 milliseconds.

2.0 SETUP

2.1 Unpack System

Unpack the unit and check for evidence of any shipping damage. If there is any visual damage, immediately notify the freight carrier to make a damage claim, and notify Megger of the damage.



CAUTION:

Potentially lethal voltages may be present on the output terminals. It is highly recommended the operator read the user manual thoroughly and have an understanding of the test set operation prior to turning power on.

2.1.1 Initial Start Up

1. With the Ethernet cable supplied with the unit connect the **IN** Ethernet Port on the SMRT unit to the Ethernet port on the PC Ethernet port. If using the STVI-2, connect the SMRT1 **IN** port to the PoE power supply **Data In** port, and connect the **Data & Power Out** port to the STVI Ethernet port.
2. Before connecting power to the unit, make sure the POWER ON/OFF Switch is in the OFF position (0). Plug the unit line cord into an appropriate power source and turn the POWER ON/OFF Switch to ON (I). As the SMRT unit goes through its power up sequence, in about a minute the STVI power up screen will appear, then the manual start up screen will appear.

2.2 Communication Ports

There are two Ethernet communication ports and an optional Bluetooth wireless port available on the Standard enclosure SMRT1. The Standard enclosure SMRT1 ports are located on the right side on the enclosure. For the Rack Mount unit the ports are located on the back panel. The Rack Mount version does not have the optional Bluetooth wireless port.

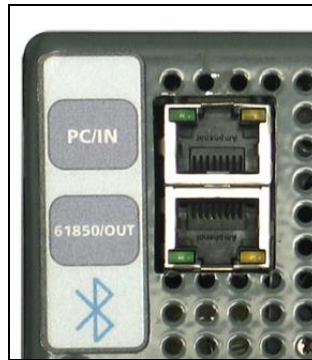

Figure 86 SMRT1 Communication Ports

2.2.1 PC/IN Ethernet Port

PC/IN Ethernet Port is a 10/100BaseTX port, and is the primary PC connection port. This port supports MDI/MDI-X auto cross over configuration, which means both standard and “crossover” Ethernet cables may be used. This port provides the optimal method for downloading EMTP files, DFR streaming, and updating the unit’s firmware as required. This port may also be used for multiple unit operation, the unit providing the **61850/ OUT** link is providing the master phase reference to all units “downstream”. In addition, the port may also used to talk to the SMRT1 unit via a Network.

2.2.1.1 Setting SMRT IP Address for Operation with a PC

With the Ethernet cable supplied with the unit, connect the **PC/IN** Ethernet Port on the SMRT1 unit to the PC Ethernet port. Turn the test set on. As the SMRT unit goes through its power up sequence, in less than a minute the Binary Output LED will flash a number of times (see more

information below). When the flashing has stopped the unit is ready. Using the PC version of the STVI software it will auto-detect the SMRT unit connected to the PC. Once it auto-detects the unit, and determines the configuration of the SMRT unit connected, the Manual screen will appear. The unit might not auto detect due to firewall settings. In this case the firewall can be turned off or you can enter the IP address directly using the PowerDB instrument configuration

screen by clicking on the Instrument Setup icon on the PowerDB tool bar . From the Instrument Configuration Screen, shown in the following figure, click off the check mark in the Auto Discover Unit box.

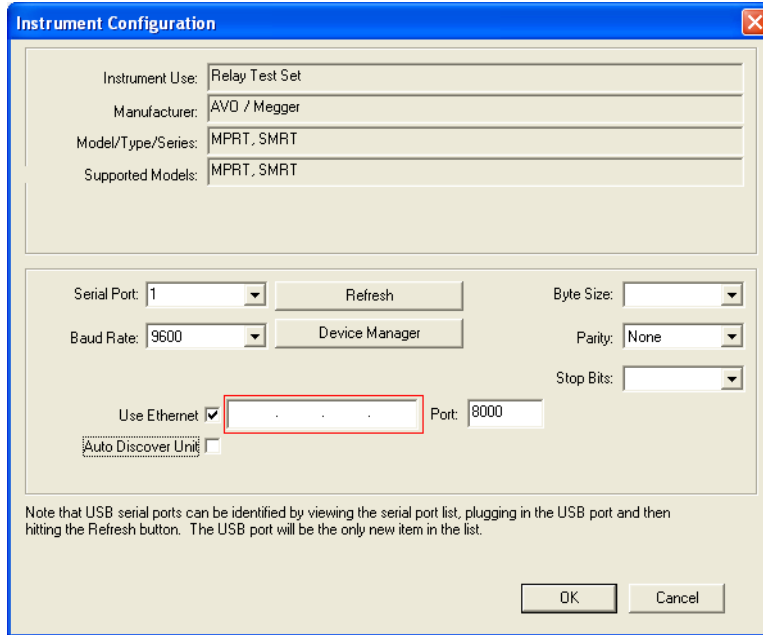



Figure 87 PowerDB Instrument Setup Screen

Here the user can enter the IP address directly into the box highlighted in red. The IP address of the unit can be determined by counting the number of times the Binary Output led flashes at the end of boot up cycle (the address is 169.254. <#flashes>.0). If the unit flashed four times, the address would be 169.254.4.0 . If the unit is on a network with a DHCP server, the user must use the Auto Discovery mode.

2.2.1.2 Setting SMRT IP Address for Networks

 The SMRT1 maybe controlled over a network. This provides remote control of the SMRT1 virtually over any distance allowing one PC to control at least two or three units simultaneously, such as in end to end testing.

 Connecting the SMRT1 to a Local Area Network or a Wide Area Network could permit unauthorized operation of the unit.

Through the IN Ethernet port, the SMRT1 integrates into a network just like a PC or server. To use this feature requires the user to setup the IP configuration of the SMRT1 for their LAN. Note that the SMRT1 when turned on will automatically search for and acquire a network address if connected to a network. If it fails to automatically acquire an address check to make sure you are properly connected using a **standard** Ethernet cable. **Do not** use the cross over Ethernet cable supplied with the test set (a cross over cable is designed for use from your PC to the test set, not to a network). If the unit still fails to acquire an address then there may be other issues. This will probably require assistance from your company's information management department.

2.2.2 61850/OUT Ethernet Port

The OUT Ethernet Port is a 10/100BaseTX port, and is used when interconnecting multiple SMRT units together. With the unit IN port connected to a PC, the OUT port would be connected to the “downstream” SMRT unit IN port, providing phase reference to all downstream SMRT units. Note that another SMRT1 IN port could be connected to the OUT port of the upstream SMRT unit, and so on thus creating a multi-phase test system. This port also provides access to the substation IEC 61850 network (when enabled) to receive and send GOOSE messages. The SMRT1 with the IEC 61850 option enabled provides selectable priority, VLAN-ID, and meets the IEC 61850-5 standard Type 1A, Class P 2/3, for high speed trip and reclose simulations.

2.2.2.1 IEC 61850 Operations

For IEC 61850 testing connect the IEC61850/OUT port to the substation bus or to the relay under test to receive and send GOOSE messages. When used with the Megger GOOSE Configurator in the AVTS software, the SMRT1 can provide high speed testing of IEC 61850 relays and substations by subscribing to GOOSE messages and mapping to the binary input. In addition, it can simulate system conditions such as circuit breaker operation by publishing GOOSE messages mapped to the SMRT1 binary output. With the PC connected to the SMRT1 IN port, and running AVTS Megger GOOSE Configurator software, the operator can “sniff” the substation network. If a secure port is desired, with the optional Bluetooth wireless port, use the SMRT1 to “sniff” the network through the IEC61850/OUT port.

3.0 Current Sources

3.1 Parallel Operation

Each SMRT current amplifier is capable of providing 30 Amperes continuous, and up to 60 amperes for 1.5 seconds for testing instantaneous trip elements. When more than 30 amps single phase is required for long durations, or 60 Amps for testing instantaneous elements, two or three current channels may be connected in parallel to provide 60 or 90 Amperes continuous, and up to 120 or 180 amperes for short durations.

To parallel the current channels of multiple SMRT1 units, perform the following:

If using the sleeved pair of current test leads (part number 2001-394), connect each current channel to the relay under test (both red and black terminals to the load). Each Megger test lead is rated for 32 Amperes continuous. If using test leads other than those supplied by Megger insure that the wire has sufficient size to carry the test current. See the following figure.

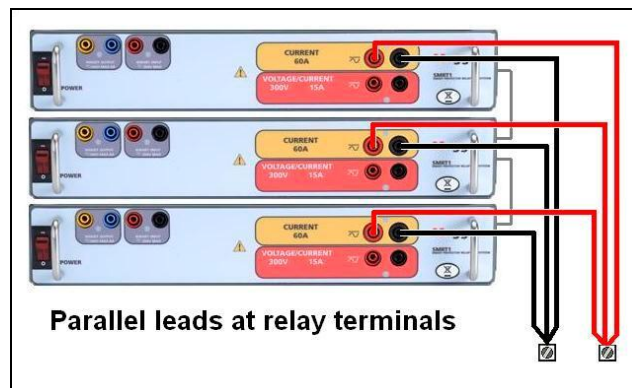

Figure 88 Parallel of Three SMRT1 Current Outputs

3.1.1 Manual Test Screen - Single Phase Up To 180 Ampere

With three SMRT1 interconnected, go to the Configuration screen and select the Operating Mode of **3 Voltages – 1 Current @ 180 amps**. When you return to the manual test screen there will be one current channel displayed, as shown in the following figure.

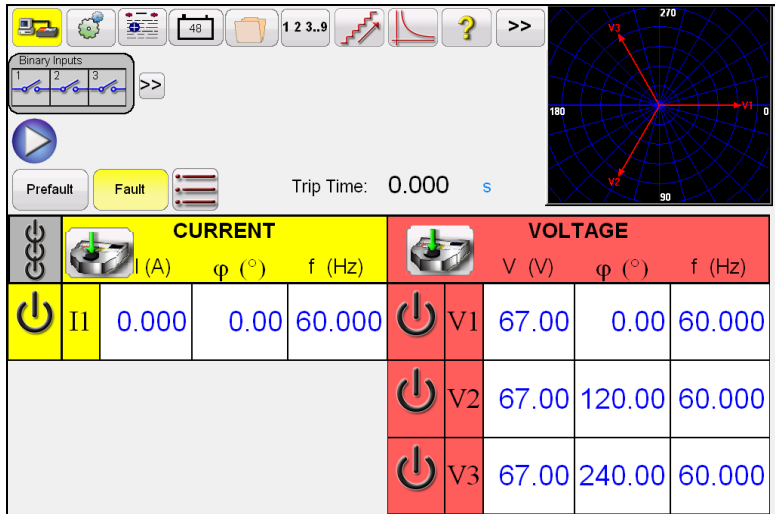

Figure 89 Manual Test Screen – Three SMRT1 Units in Single Phase Operation

The STVI will automatically set all three currents in phase with each other and divide the current equally between the three current amplifiers. When setting an output, simply enter the value of the desired output current. For example, for an output of 75 Amperes, enter 75, while each current amplifier will be providing 25 Amperes. The current can also be phase shifted. Simply enter the desired phase angle and all three currents will be phase shifted together.

If two current channels that are to be used in parallel, connect the two current outputs to the load as shown in the following figure.

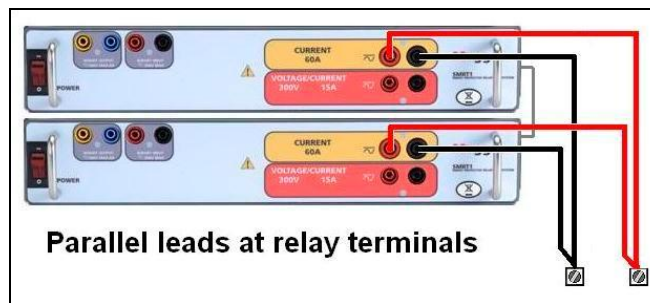



Figure 90 Two Currents in Parallel

Set each channel to one-half of the output requirement. Be sure and reset current channel #2 to 0 degrees so that it will be in-phase with current channel #1. With both current channels selected, turn output on by pressing or clicking on the ALL ON/OFF button. Always use the ALL ON/OFF button to turn both current channels on and off together. For manually ramping outputs, if using the PC version of the STVI software the \uparrow / \downarrow buttons will be displayed. If using an STVI controller the Control Knob icon  will be displayed. Pressing either of these two will present the user with a window to select the desired level of increment for manually ramping the outputs, the desired channel(s) to be ramped, and what is to be adjusted (amplitude, phase angle or frequency).

3.2 Currents in Series Operation

Two current channels may be connected in series in order to double the available compliance voltage. High impedance electromechanical ground (earth) overcurrent relays have always been difficult to test at high multiples of tap due to the winding impedance and saturation characteristics. The peak voltage required can exceed the maximum output voltage of one SMRT1 current output channel, depending on the required test current. By connecting two current outputs in series, the compliance voltage is doubled, providing higher test currents through the load. Connect the two current amplifiers in a “push-push” configuration as shown in the following figure.

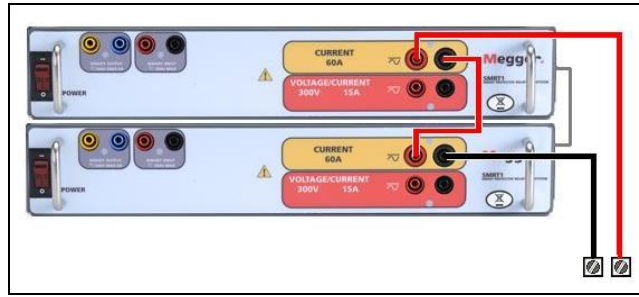



Figure 91 Series Two Currents

Using the STVI or the STVI software on a PC set each of two current channels to the same test current magnitude, and phase angle. Select both current channels and turn output on by pressing or clicking on the ALL ON/OFF button. Always use the ALL ON/OFF button to turn both current channels on and off together. For manually ramping outputs, if using the PC version of the STVI software the $\uparrow\downarrow$ buttons will be displayed. If using an STVI controller the Control Knob icon  will be displayed. Pressing either of these two will present the user with a window to select the desired level of increment for manually ramping the outputs, the desired channel(s) to be ramped, and what is to be adjusted (amplitude, phase angle or frequency).

4.0 Voltage Sources

4.1 Outputs Summed Together

Two voltage channels may be used to sum the voltage outputs to obtain higher than rated voltage provided the load is ungrounded. Connect the load between the voltage channel posts, set V_1 Phase to 0° and set V_2 Phase to 180° . The voltage outputs will add so the total voltage is the sum of the two voltage amplitudes, V_1 and V_2 as can be seen in the picture below.



Connect the associated voltage channels black common returns together, when series operation is required (see the following figure). DO NOT attempt to series more than two voltage channels together since the test leads are rated up to maximum of 600 Volts.

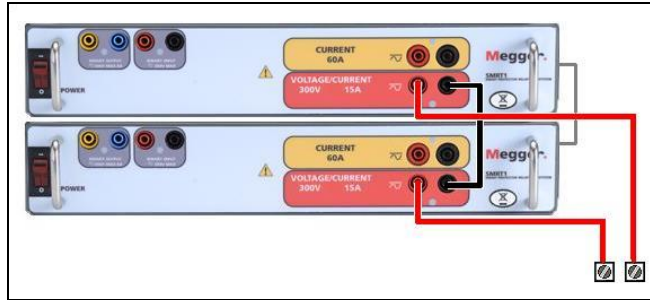

Figure 92 Series of Voltage Channels

4.2 3Ø, 3-Wire, Open-Delta and T-Connection

4.2.1 Balanced Open Delta

Two methods of obtaining a three-phase, three-wire voltage source are available. The Open-Delta configuration is the easier to use when a balanced three-phase source is required because the amplitude and phase relationship can be set directly. No calculations are necessary.

When using the Open-Delta configuration, it is suggested to use voltage channel #1, designated V_1 , and voltage channel #2, designated V_2 , while the COMMON binding post is designated V_g . With this arrangement, the magnitude and phase angle of the potentials can be easily calculated and set. For the balanced three-phase condition V_{1g} and V_{2g} are equal in magnitude and separated by an angle of 60° . This is done by setting the V_1 and V_2 potentials equal in magnitude, setting 0° on V_1 and 300° (60 degrees leading assuming that the default phase rotation is set to 360 Lag) on V_2 , see the following figures.

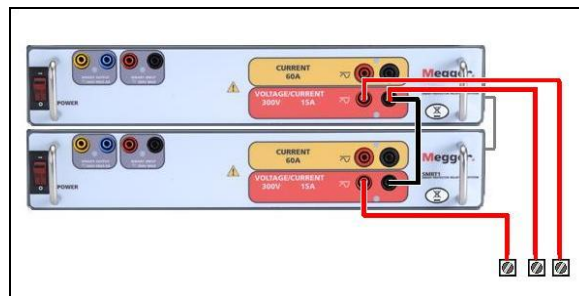
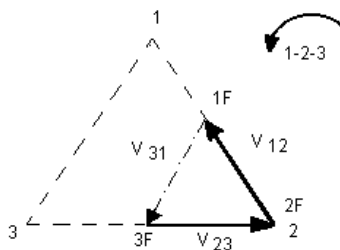

Figure 93 Three Phase Open Delta Connections

When using the Open-Delta Configuration to set up a phase-to-phase fault, calculations' using the Law of Cosines is required to calculate amplitude and phase relationships. (See discussion under T-Connection for simulating unbalanced, phase-to-phase faults without need for calculations.)



Balanced 3Ø - Open Delta Connection
 If V_f equals the desired test potential, then:
 Set $V_1 = V_f \angle 0^\circ$
 Set $V_2 = V_f \angle 300^\circ$ Lagging (60° Leading)

4.2.1.1 Unbalanced Open Delta

When setting up an Unbalanced Open-Delta configuration, the desired phase-to-phase fault voltage, V_{1f} is set using voltage channel #1 with its phase angle set to 0° . Phase-to-phase voltage V_{2f} and its phase angle relationship for voltage channel #2, must be calculated using the Law of Cosines; where For any triangle the following formula applies:

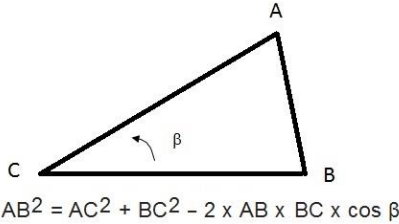

The next figure shows the phase relationships between voltages and an example of the necessary calculation. For convenience the amplitude and the phase angle settings for the typical V_f fault magnitudes are tabulated.

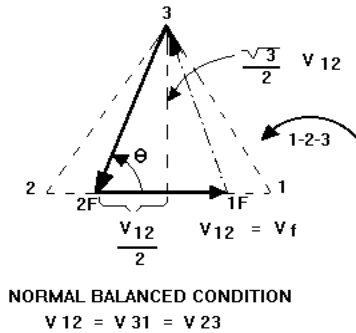

Figure 94 Open-Delta Unbalanced phase-to-phase Fault Voltages

$$\theta = \arccos\left(\frac{V_{12}}{2 * V_{23}}\right)$$

From the Law of Cosines

$$V_{23}^2 = \left(\frac{V_{12}}{2}\right)^2 + \left(\frac{\sqrt{3}}{2} * 120\right)^2$$

Settings for Typical Phase-to-Phase Fault Voltages

$$V_{12} = V_{\text{fault}}$$

V_{12}	1	5	10	15	20	25	30	35	40	45	50	55	60	65	70
V_{23}	104	104	104	104	104	105	105	105	106	106	106	108	108	109	110
At θ°	270	271	273	274	275	277	278	280	281	282	284	285	286	287	289
Lag															

4.2.2 T Connection

The second method of obtaining a three-phase, three-wire voltage source is the so-called T-Connection. The method, shown in the following figure, is easier to use when obtaining an unbalanced, phase - to -phase fault simulation since it eliminates calculations. To reduce confusion when using the T-Connection, the voltage output #1 is designated V_a and its phase angle set at 0° , voltage output #2 is designated V_b and its phase angle set for 180° , and voltage output #3 is designated V_c and its phase angle is set for 270° . Any combination of balanced three phase faults or unbalanced phase-to-phase fault conditions can be easily simulated. The following figure indicates these phase relationships.

!NOTE: This method should not be used for very low fault voltages, or used on solid state relays that may be sensitive to this type of connection (i.e. 5 volts or less, or for testing ABB or Westinghouse type SKD relays).

$$V_f = \text{Desired Fault Voltage}$$

$$V_a = \frac{1}{2}V_f \angle 0^\circ$$

$$V_b = \frac{1}{2}V_f \angle 180^\circ$$

$$V_c = \frac{\sqrt{3}}{2}V_f \text{ or } V_c = 104V \angle 270^\circ$$

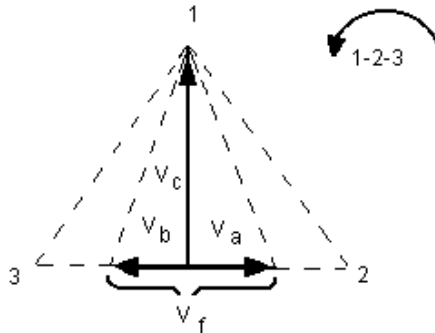

Balanced or Unbalanced Fault T-Connection

4.3 3Ø, 4-Wire, Y-Connection

A three-phase, four-wire potential system can be provided using three output modules. The vector relationships are referenced below. This Y-Connection has the advantage of being able to supply a higher line-to-line voltage (1.73 x phase-to-neutral voltage). It is ideally suited for simulating phase-to-ground faults. Voltage channel #1 is designated as V_a with its phase relationship set for 0° . Voltage channel #2 is then designated as V_b and phase angle set for 120° . Finally, voltage channel #3 is designated V_c and phase angle set for 240° (for a 1-2-3 counter

clockwise rotation). V_a , V_b and V_c are connected to the voltage potential binding posts on the respective test sets.

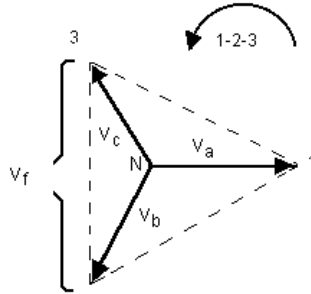

Balanced 3 ϕ , 4 Wire Y-Connection

$$V_f = \text{Desired Fault Voltage}$$

$$V_a = \frac{\sqrt{3}}{3} V_f \angle 0^\circ$$

$$V_b = \frac{\sqrt{3}}{3} V_f \angle 120^\circ$$

$$V_c = \frac{\sqrt{3}}{3} V_f \angle 240^\circ$$

If using the optional sleeved multi-lead voltage test leads (part number 2001-395), all of the black return leads are interconnected together inside the sleeve so they will all share the return together. Therefore, only one return lead is provided on the relay connection side of the sleeved leads (similar to the connections in the following figure).

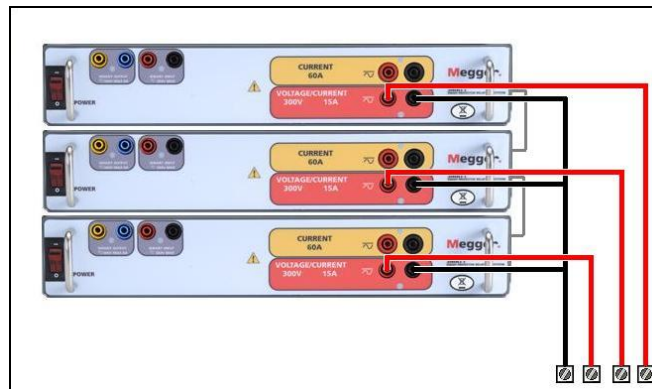

Figure 95 Three Phase Four Wire Voltage Test Connections

5.0 Warranty Statement

Megger warrants the product is free of defects in material and workmanship for a period of one (1) year from date of shipment. This warranty is non-transferable. This warranty is limited and shall not apply to equipment that has damage, or cause of defect, due to accident, negligence, and improper operation, faulty installation by the purchaser, or improper service or repair by any person, company or corporation not authorized by Megger. Megger will, at its' option, either repair or replace those parts and/or materials it deems to be defective.

The warranty is in lieu of all other warranties, either expressed or implied on the part of Megger and in no event shall Megger be liable for the consequential damages due to the breach thereof.

5.1 Preventive Maintenance

The unit utilizes surface mount technology (SMT) and other components which require little or no service except for routine cleaning, etc. The unit should be serviced in a clean atmosphere away from energized electrical circuits.

5.1.1 Examine the unit every six months for:

Dust and Dirt	To clean the unit, disconnect the power cord from the unit. Never use spray liquids or industrial cleaners. Some cleaning solvents can damage electrical components, and should never be used. Water and a mild soap may be used. Use a lightly damp cloth (not dripping wet) to wipe off the unit. A dirty heat sink can cause thermal overloads. Remove dust with dry, low pressure, compressed air. Either remove the enclosure or simply apply air forcing the dust away from the heat sink through the sides of the unit.
Moisture	Remove moisture as much as possible by putting the test set in a warm, dry environment.

5.1.2 Updating SMRT1 Firmware

Download Firmware Upgrade via Megger Website

To download the newest firmware from the Megger website,

1. Go to WWW.Megger.com
2. **Log In.**
3. Go to **Software Downloads**
4. Click on **SMRT**
5. You will see instructions to enter the serial number of the SMRT unit, and then click on **Continue**. The serial number is 12 digits long. Make sure you enter all 12 digits. Then click on **Firmware Version #.##**. The firmware will be downloaded onto your PC as a zip file. Unzip the file, **Select All** files, and **Copy** to a USB memory stick³ (use a 2 GB or smaller stick), or create a file on your PC for storage to unzip or extract to a file.

³ You can use the STVI USB port to update the SMRT firmware using a memory stick (2 GB or **smaller**) with the firmware on it. The STVI USB port does not support memory sticks larger than 2 GB.

USB Memory Stick: With the SMRT and STVI powered up, insert the USB memory stick into the USB port on top of the STVI. Press the **Configuration** Screen button, and then press the **Update Firmware** button in the Configuration Screen. At that point the user will be presented with the IP Address selection screen, with the serial number of the unit. Select the unit by touching the serial number and the upgrade process will automatically start. That's all there is to it. Observe the STVI display screen, and the unit. At the completion of the download, the user will note the fans spin-up, and the LED's will be flashing rapidly on the SMRT unit. There will be an instruction to reboot (turn off and back on) the test system.

PC and STVI Software: If using the PC version of the STVI software, it is very similar to the STVI. Upon clicking on the Update Firmware button, the familiar Windows *Open File* browser dialog box will appear. Using the *Look In* pull-down menu, navigate to where the new firmware was downloaded onto the PC, click on and open the file folder SMRT_LDR (SMRT Loader). There you will find the new firmware file. Click on the file, and click on Open. You will be requested to select a unit from the IP Address screen. Select the unit by clicking on the serial number and the upgrade process will automatically start. At the completion of the download, the user will note the fans spin-up, and the LED's will be flashing rapidly on the SMRT unit. There will be an instruction to reboot (turn off and back on) the test system. Note that after rebooting the SMRT unit, if using the PC version of the STVI software you will have to restart the STVI software on your PC in order to regain control of the SMRT unit

5.2 Service and Repair Instructions

Basic troubleshooting information has been provided to guide the technician to the possible source of a problem.

Since SMRT1 uses Surface Mount Technology, most repairs are beyond the scope of the basic troubleshooting guide, and should be referred to the Service Department at Megger or handled through the Megger Representative.

 If the unit is still within the original warranty period, or limited warranty period following factory servicing, **the factory must be contacted before attempting any repairs or the warranty will be void.**

5.2.1 Basic Troubleshooting

The troubleshooting information relies on the technician to have a good understanding of the operation of the unit. If the technician is unfamiliar with the unit, he or she should not attempt to repair. The technician should contact the factory before attempting repairs. Provide the Megger part number for the part or assembly in question and the serial number of the SMRT1 when making inquiries.



WARNING It is necessary to energize the SMRT1 to properly troubleshoot. The technician must take all applicable safety precautions for working near energized circuits.

NOTES

Before suspecting a failure in the SMRT1, review the General Description and Operation sections to ensure that the problem is not a result of operating error.

Preliminary testing of the SMRT1 within its specified limits can help determine if a malfunction actually exists, identify the type of malfunction and define the general area of the failure.

Common causes of malfunctions, other than improper operation, are incorrect power input (voltage above or below specified limits), incorrect test signal voltages applied to the Binary Input

gate (outside of the specified AC/DC Applied/Removed limits), and contact or circuit resistance too great for the Dry Contact gates to operate properly on the Monitor/Start/Stop gate. Typical malfunctions for the VI-Gen amplifiers are external short circuits on the voltage output and open circuits on the current output. VI-Gen voltage and current outputs can be easily checked using a voltmeter and ammeter.

! **NOTE:** Proper ESD procedures should be followed when handling any SMRT1 VIGEN outside of the protective enclosure. Failure to do so, may damage sensitive parts.

5.2.1.1 Power Input

Input voltage affects the whole unit and may or may not cause permanent damage if voltage is incorrect. These problems can often be corrected by simply using a better source of input power. The rated voltage limit is auto-selectable from 100 to 240 volts, $\pm 10\%$, 47 to 63 Hz.

Some symptoms are as follows:

1. Low voltage: Erratic operation, no output, input power circuit breaker operation.
2. High voltage: Circuit breaker operation, power supply failure in Input Power Module.

5.2.1.2 VIGEN Input Power and Control

Basic troubleshooting of the input power is as follows.

No power: Check the ON/OFF circuit breaker. Does the ON/OFF switch light up? If it does not light up, then power is not getting to the unit. Check power source and line cord. If it lights up then the power is getting to the unit. Check the VIGEN internal power cable connections.

! To check the internal connections requires the removal of the enclosure cover and the Warranty Sticker. If the unit is still in the warranty period, stop and contact your local Megger Sales office or representative. If in warranty, do not remove the sticker without written approval from Megger. Removing the warranty sticker without written approval may void the warranty.

Step 1 Disconnect the power cord from the unit, and remove top corner screws.



Step 2



Step 3

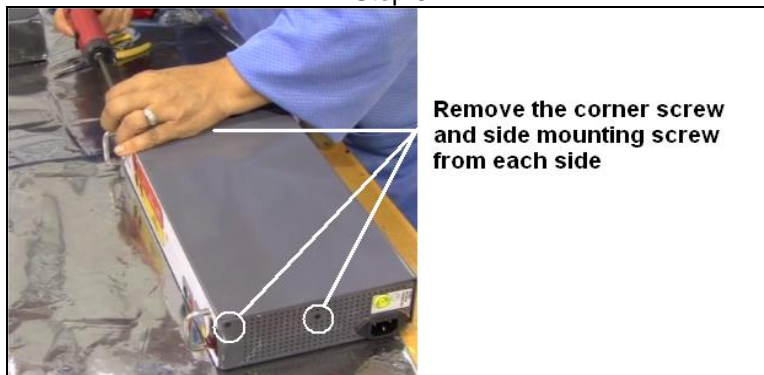

Step 4

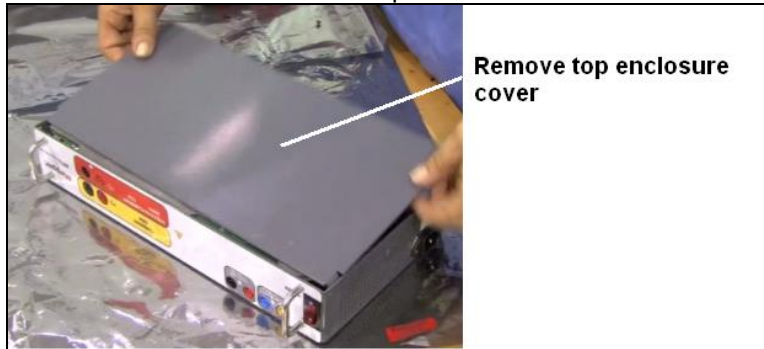

CAUTION: From this point on observe proper ESD procedures. Be careful when moving the VIGEN module as it is a tight fit, and it is possible to damage components upon extraction from or installation to the bottom half of the enclosure.

Step 5



Remove two screws that secure the power input receptacle

Step 6

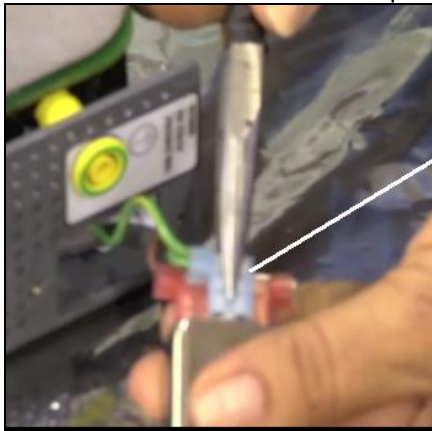

Disconnect the connectors to the power receptacle. Take note of the color coded wires and the appropriate connectors.

Step 7



Carefully remove the VIGEN from the enclosure shell enough to gain access to the power ON/OFF switch and Ground post connection points

Step 8



Disconnect the ground and power on off switch connectors

Step 9

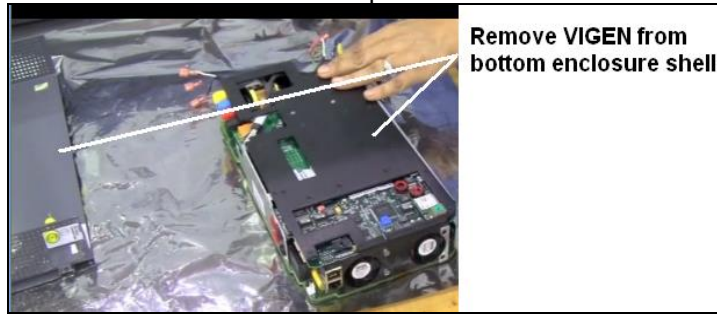

Step 10 Inspect the AC power connector

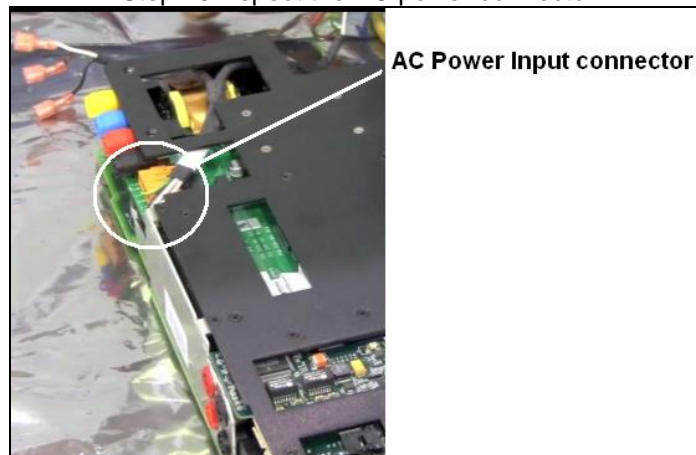

Look for possible discoloring of the wires and connector indicating overheating. Make a general observation of the VIGEN module looking for any obvious damage caused by a short circuit or other possible signs of trouble.

5.2.1.3 Binary Input and Binary Output

If all the items external of the unit are in proper order, then the problem exists within the Binary Input / Output assembly itself.

Some basic troubleshooting can pinpoint problems to the approximate cause.

Binary Input - Basic troubleshooting is as follows:

1. Timer does not stop:

Jumper the Binary Input terminals manually. If LED above the input lights, check the Binary Input setup screen to verify that the selected binary input is properly setup as a Timer stop post. Check Timer stop settings as N.O. (Normally Open) to close, and Latch On. If LED does not light up, the Binary Input will need to be repaired or replaced.

2. Counting errors:

AC applied or removed Stop signals can create, what appears to be poor repeatability, an inaccuracy or a malfunction in the Timer. The lower the voltage level, the more serious the "error" will be. What appears to be an error, however, is actually a variation in the point on the sine wave at which the voltage is great enough to cause the gate circuit to operate. If the circuit used for the timing test has a low AC voltage and the point at which the contact in the test circuit opens or closes, is at or close to zero on the sine wave, the period of time before the voltage level will be high enough to trigger the gate circuit can be as much as 4 milliseconds. The

total timing variation can be as much as 8 milliseconds. The shorter the duration of the timing test, the more significant the variation becomes. Therefore, if small timing variations would present a problem, it is recommended that an AC voltage of 115 volts or above or a DC voltage be used for voltage applied/removed test selections.

When the SMRT1 Timer calibration is being tested, the AC voltage variable is often overlooked. This is particularly true when the Timer is compared to a counter and the two are triggered simultaneously with an electronic switch. For best results, a DC voltage should be used to eliminate the variable. If testing the AC voltage Timer Stop characteristics is desired, then the Stop signal must be triggered at the same point on the sine wave to assure that the gate signal will be repeatable. Ideally, the signal should be at a point near peak in the positive direction. In addition, the specified rms AC voltage values for the various Stop control selections must be adhered to.

Another source of apparent "error" can be the programmable de-bounce feature. If using electro-mechanical contacts for stopping the Timer, and if those contacts have a tendency to bounce, there could be a difference between an external standard timer and the SMRT1 Timer, depending on the programmed de-bounce period set in the SMRT unit. To determine the programmed value, look at the Binary Input Setup Screen and see what the De-bounce setting value is.

If a timing error or variation persists after all the suspected causes of error have been eliminated, then it is possible that the Binary Input circuit is malfunctioning. Contact factory for return instructions.

Binary Output - Basic troubleshooting is as follows:

Binary Output LED is ON but output contacts **not closed**:

Using a continuity tester check to see if output circuit is open circuited. If circuit is open then it is possible that the internal surface mounted fuse element has been blown. Note: an optional in-line fused test lead Part Number: 568026 are available to provide protection from switching too high current, see SMRT Ordering Information under Optional Additional Accessories. The unit will need to be returned to the factory for further inspection and repair.

 Contact the factory for a Repair Authorization Number and return instructions if service is required. A Repair Authorization (RA) number will be assigned for proper handling of the unit when it arrives at the factory. Any non-warranty repair cost incurred for the repair or replacement of parts and/or materials shall be the responsibility of the purchaser.

Provide the factory with model number, Unit serial number, serial number of VI-Gen if appropriate, nature of the problem or service, return address, your name, and how to contact you should the factory need to discuss the service request.

You may need to provide a purchase order number, cost limit, billing, and return shipping instructions. If an estimate is requested, provide the name and contact information.

6.0 Preparation for Reshipment

 Save the original shipping container for future use. The shipping container is designed to withstand the rigors of shipping via a common commercial carrier. For example, you may wish to reship your unit to Megger for an annual calibration recertification.

Pack the equipment appropriately to prevent damage during shipment. If a reusable container is utilized, the unit will be returned in the same shipping container if it is in suitable condition.

Add the Return Authorization Number to the address label of the shipping container for proper identification and quicker handling.

 NOTE: Ship the equipment without nonessential items such as test leads, etc. These items are not needed by the factory to perform service.

Megger[®]

Addendum B













* SMRT36 shown with "P" Plus option (Extra Binary Inputs / Outputs and battery simulator)

Model SMRT33/36 **Megger Relay Tester**

SAFETY PRECAUTIONS

VOLTAGES GENERATED BY THIS INSTRUMENT CAN BE HAZARDOUS

This instrument has been designed for operator safety; however, no design can completely protect against incorrect use. Electrical circuits are dangerous and can be lethal when lack of caution and poor safety practices are used. There are several standard safety precautions that should be taken by the operator. Where applicable, IEC safety markings have been placed on the instrument to notify the operator to refer to the user manual for instructions on correct use or safety related topics. Refer to the following table of symbols and definitions.

Symbol	Description
	Direct Current
	Alternating Current
	Both direct and alternating current
	Earth (ground) Terminal. There is a common chassis ground terminal located on the front panel (see Front panel under Description of Controls).
	Protective Conductor Terminal
	Frame or Chassis Terminal
	On (Supply)
	Off (Supply)
	Caution, risk of electric shock
	Caution (refer to accompanying documents)

 **WARNING:** Under no circumstances should the operator or technician attempt to open or service this instrument while connected to a power source. Lethal voltages are present and may cause serious injury or death!

SAFETY PRECAUTIONS (Continued)

The following are some specific safety related items associated with the SMRT test system.

Read and understand all safety precautions and operation instructions before attempting to use this unit.

The purpose of this equipment is limited to use as described in this instruction manual. Should a situation arise that is not covered in the general or specific safety precaution please contact Megger regional representative or Megger, Dallas Texas.

Safety is the responsibility of the user. Misuse of this equipment can be extremely dangerous.

Always start with the power OFF, before connecting the power cord. Make sure outputs are off before attempting to make test connections.

Never connect the test set to energized equipment.

Always use properly insulated test leads. The optional test leads are rated for the continuous output ratings of the test system, and should be properly used and cared for. DO NOT use cracked or broken test leads.

Always turn the test system off before disconnecting the power cord.

DO NOT attempt to use the unit without a safety ground connected.

DO NOT attempt to use the unit if the power cord ground prong is broken or missing.

DO NOT use the test set in an explosive atmosphere.

The instrument must only be used by suitably trained and competent persons.

Observe all safety warnings marked on the equipment.

For safety related or other important topics, like the statement below, will be notated with the adjoined symbol. Read the topic carefully as it may relate either to the safe operation of the test system or the safety of the operator.



Under no circumstances should the operator put their hand or tools inside the test system chassis area with the test system connected to a power source. Lethal voltages are present and may cause serious injury or death!

1.0 Operation

The unit's design is a "modular" concept. All inputs and outputs are clearly marked and logically grouped so continual reference to the instruction manual should not be necessary once the operator is acquainted with the test system. The unit's Top Panel will appear different among units, since each unit may have up to three optional Voltage/Current Generator (VIGEN) Modules installed. The 'N' version consists of a system board with only the power and communication ports. The 'P' version adds 8 additional binary inputs, 4 additional binary outputs and a battery simulator.

1.1 General Description

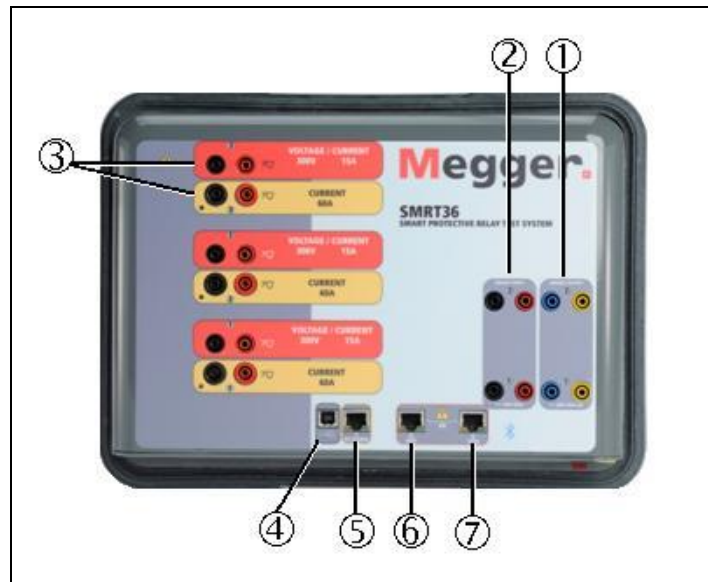

Figure 96 Top Panel SMRT33/36 (SMRT36 Pictured with Floating Returns Option)

1.1.1 Top Panel

9. **Binary Outputs** – the first two VIGEN modules include Binary Inputs and Binary Outputs. Therefore, with a minimum 2 channel unit there are 2 Binary Outputs located on the top panel (numbered 1 and 2). More Binary Outputs are available with the P option see Front Panel section for more information. Each Binary Output can be configured as Normally Open or Normally Closed contacts providing logic to the device under test. The Top Panel Binary Outputs can switch up to 300 VAC or 250 VDC with 8 Amp continuous. The programmable wait duration is from 1 millisecond to 10,000 milliseconds.
10. **Binary Inputs** – with a minimum 2 channel unit there are 2 Binary Inputs located on the top panel. More Binary Inputs are available with the P option see Front Panel section for more information. The Binary Inputs will accept a voltage range of 5 to 300 VAC, or 5 to 250 VDC, or dry Normally Open / Normally Closed contacts.
11. **Voltage/Current Generator Module (or VIGEN)** – There are three available slots for the VIGEN Modules. The slots are numbered 1 to 3 from bottom to top, with the topmost VIGEN numbered 3. The three phase voltages and currents are noted by the red and yellow surrounding each output channel. Phases A, B and C Voltage Channels (V1, V2 and V3) are denoted by the red color. Phases A, B and C Current Channels (I1, I2 and I3) are denoted by the yellow color. When the voltage generators are converted to current

generators, they will change on the STVI display as V1 = I4, V2 = I5 and V3 = I6. For more details on the VIGEN output capabilities see section 1.4.

Note: The SMRT33 voltage channels are not convertible to currents.

12. **USB Interface** – the USB 2.0 Interface requires a Type B “downstream” connector, and is primarily used as a communication and control port when used with a PC and Megger AVTS software for automated relay testing. A USB cable is not provided with the test set or in the optional accessories. For computer control, an Ethernet cable is provided. However, should the user desire to use the USB port any standard USB A/B cable will work with the unit. May be used when isolation is required for a secure substation access between the SMRT and the IEC 61850 substation network.
13. **PC/OUT Ethernet Port** is a 10/100BaseTX port, and is the primary PC connection port. This port supports MDI/MDI-X auto cross over configuration, which means both standard and “crossover” Ethernet cables may be used. This port provides the optimal method for downloading EMTP files, DFR streaming, and updating the unit’s firmware as required. The SMRT comes standard with a crossover cable. This port may also be used for connecting to the IEC 61850 substation bus for use in testing IEC 61850 devices. For multiple unit operation, the unit providing the OUT link is providing the master phase reference to all units “downstream”.
14. **IN - 61850 Ethernet Port** is a 10/100BaseTX port, and is primarily used to interconnect multiple SMRT units together for synchronous multi-unit operation. It may also be used to provide access to the substation IEC 61850 network. Note that the IN and STVI ports share a common physical port and cannot be used at the same time. With the PC connected to the PC Port, the SMRT and the PC share the same Ethernet network connection, and thus will not have a secure isolation from each other.
15. **STVI Ethernet Port** – this Ethernet port is a 10/100BaseTX PoE (Power over Ethernet) port, and is the STVI connection port. Used for manual operation, and display outputs when under computer control.



1.1.2 Front Panel:

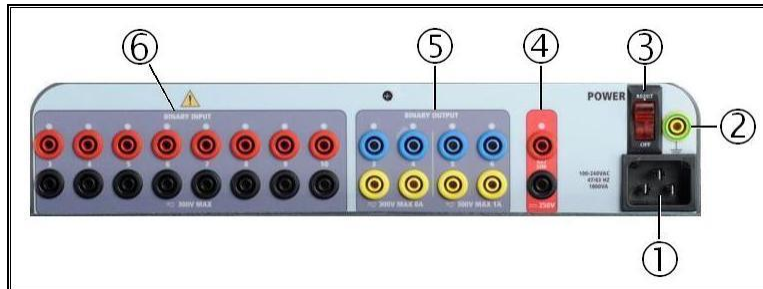

Figure 97 SMRT33/36 with P Option Front Panel

1. **Incoming Power / Line Cord** – the input line cord, ground terminal, are mounted on the front panel of the test set for both the N and P option units.

Input Line Cord

The test set is equipped with a line cord, which connects to the male connector on the front panel. Verify the input voltage rating on the front panel before connecting the line cord to the power source.



2. **Earth Ground Jack** – use this terminal to connect chassis ground to earth ground.

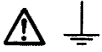

A chassis ground (earth) point on the front panel is provided as an additional safety ground.

3. **POWER ON/OFF Switch** – used to switch unit on and off. The switch illuminates when power is on.
4. **Battery Simulator** – the SMRT33/36 with the P option provides a variable dc output voltage from 5 to 250 Volts, at 100 Watts (4 Amps Max) providing logic voltage for solid-state relays. When powered ON, the LED above the output terminals illuminates. The SMRT33/36 with the N option does not include a battery simulator.
5. **Binary Outputs** – the P option provides 4 additional Binary Outputs, numbered 3, 4, 5 and 6. Each Binary Output can be configured as Normally Open or Normally Closed contacts providing logic to the device under test. Binary Outputs 3 and 4 have an AC Rating of 400 V max., I_{max}: 8 amps, 2000 VA max. breaking capacity, and a DC Rating of 300 V max., I_{max}: 8 amps, 80 Watts, with a Response Time: < 10ms. Binary Outputs 5 and 6 are high speed and have an AC / DC Voltage Rating of 400 V peak, I_{max}: 1 amp, with a Response Time: < 1ms typical. The programmable wait duration is from 1 millisecond to 10,000 milliseconds. An LED directly above the terminals indicates the status of the contact. ON indicates closed, and OFF indicates open. The SMRT33/36 with the N option does not include the additional Binary Outputs 3 through 6.
6. **Binary Inputs** – the P option provides 8 additional (numbered 3 through 10), independent, galvanically isolated, Start/Stop or Monitor circuits to monitor operation of relay contacts or trip SCR. A continuity light is provided for each input gate. Upon sensing continuity, or voltage applied, the lamp will glow. In addition to serving as wet/dry contacts the Binary Inputs may be programmed to trigger binary output sequence(s). Binary Inputs can also be programmed using Boolean logic for more complex power system simulations. The Binary Inputs will accept a voltage range of 5 to 300 VAC or 5 to 250 VDC, or dry Normally Open / Normally Closed contacts. The SMRT33/36 with the N option does not include the additional Binary Inputs 3 through 10.

1.2 Input Power

The input voltage rating varies depending upon the model number. If the model number has a letter **F** or **G** in the 5th digit, the input voltage may be from 100 to 240 VAC, $\pm 10\%$, 50/60 Hertz. If the letter is either **C** or **E**, the input voltage may be from 220 to 240 VAC, $\pm 10\%$, 50/60 Hertz. Total maximum output power will be limited for CE marked units⁴. Input current required varies with the number of output modules in use, load, and input voltage value. With three VIGENS, the maximum input power is 1800VA. The input is protected by a power ON/OFF switch / circuit breaker.

1.2.1. Input Power Cord

Depending on the country, the power cord can come with a NEMA 5-15 male connector, a CEE 7/7 Schuko two prong connector, with International Color Coded pig-tail wires (light blue, brown and green with yellow stripe) with the insulation jacket stripped ready for installation of the appropriate male connector, or with UK power cord.

⁴ For CE mark units only (C or E in the 5th digit), a derating of the simultaneously available total output power of the current / voltage amplifiers and battery simulator will occur. The maximum output power of a single amplifier is not affected.

Model SMRT33/36 **X0XXXXA** comes with a North American power cord (part number 620000).

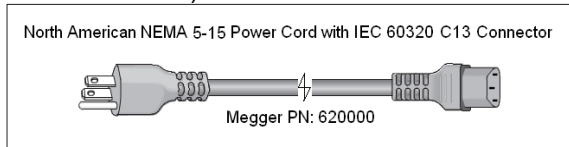

Model SMRT33/36 **X0XXXXE** comes with a Continental Europe power cord (part number 50425).

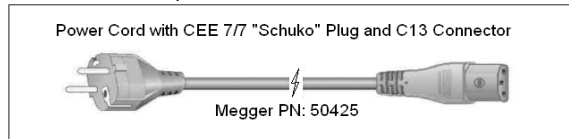

Model SMRT33/36 **X0XXXXI** comes with an International Color Code power cord. The cord, part number 15065, is ready for wiring to the appropriate plug (depending on country). The following colors apply, Brown = Line, Blue = Neutral and Green/Yellow = Ground.

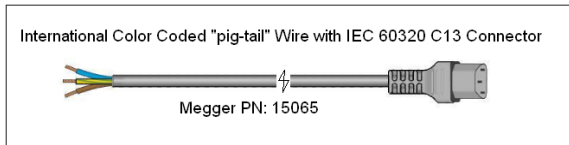

Model SMRT33/36 **X0XXXXU** comes with a UK power cord (part number 90002-989).

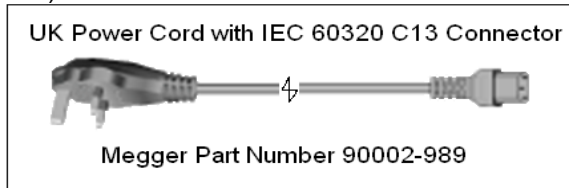

1.3 Voltage - Current Generator (VIGEN) Module

Voltages and Currents are noted by the red and yellow surrounding each output channel. Phases 1, 2 and 3 voltage channels are denoted by the red color. Phases 1, 2 and 3 current channels are denoted by the yellow color. All outputs are independent from sudden changes in mains voltage and frequency, and are regulated so changes in load impedance do not affect the output. Standard amplifier outputs are isolated or floating. The SMRT units can be ordered with the amplifier common returns tied to chassis ground as an option.

1.3.1. Convertible Voltage/Current Amplifier

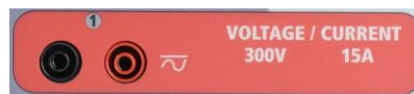

Figure 98 SMRT36 Voltage Channel

The SMRT PowerV™ voltage amplifier provides a flat power curve from 30 to 150 Volts in the 150V range to permit testing of high current applications such as panel testing.

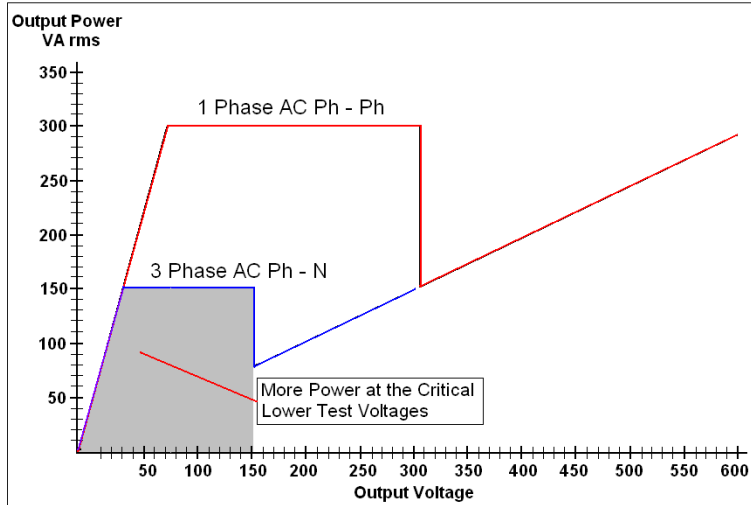

Figure 99 SMRT Voltage Amplifier Power Curve

Voltage Range

30.00V
 150.00V
 300.00V

Power / Current (Max)

150VA @ 5.0A
 150VA Constant Output Power from 30 to 150 Volts
 150VA @ 0.5A

Voltage Amplifier in Current Mode⁵:

The SMRT36 voltage amplifier is convertible to a current source with the following output capability. Output power ratings are specified in rms values and peak power ratings.

Output Current	Power	Max V	Duty Cycle
5 Amperes	150 VA (212 peak)	30.0 Vrms	Continuous
15 Amperes	120 VA	8.0 Vrms	90 Cycles

With a 3 channel SMRT unit, convertible channels in conjunction with the three main current channels, provides 6 currents for testing three phase current differential relays. When the voltage generators are converted to current generators, they will change on the STVI display as current phases 4, 5 and 6.

! The voltage amplifier output is protected from short circuits and thermally protected against prolonged overloads. In case of a short circuit or a thermal overload, the amplifier will automatically turn off, and if the STVI is connected a message to the user will be displayed indicating which condition exists. If AVTS software is used, a similar message will appear.

1.3.2. Current Amplifier



Figure 100 SMRT36 Current Channel

The SMRT current amplifier Constant Power Output feature delivers maximum compliance voltage to the load constantly during the test, and range changing is done automatically, on-the-fly, under load. This insures better test results, saves time by not having to turn the outputs off to change output taps or ranges, and unlike single range current amplifiers insures a higher compliance voltage at lower test currents. Constant Power Output in many cases eliminates the need to parallel or series current channels together to test high burden relays.

⁵ The SMRT33 Voltage Amplifier is not convertible to a current channel

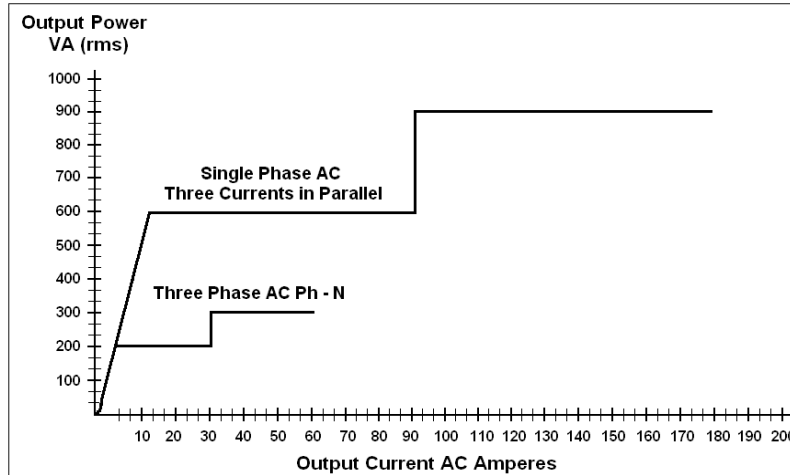



Figure 101 SMRT36 Current Amplifier Constant Power Output Power Curves

The following are typical output current and associated available compliance voltage values for the SMRT33/36 Current channel⁶. The per channel output current and power ratings are specified in AC rms values and peak power ratings. Specified duty cycles are based upon typical room ambient temperature.

Output Current	Power	Max V / Duty Cycle
1 Ampere	15 VA	15.0 Vrms Continuous
4 Amperes	200 VA (282 peak)	50.0 Vrms Continuous
15 Amperes	200 VA (282 peak)	13.4 Vrms Continuous
30 Amperes	200 VA (282 peak)	6.67 Vrms Continuous
45 Amperes ⁵	300 VA (424 peak)	6.67 Vrms 90 Cycles
60 Amperes	300 VA (424 peak)	5.00 Vrms 90 Cycles
DC 200 Watts		

 The current amplifier output is protected from open circuits and thermally protected against prolonged overloads. In case of an open circuit or a thermal overload, the amplifier will automatically turn off, and if the STVI is connected a message to the user will be displayed indicating which condition exists. If AVTS software is used, a similar message will appear.

1.4 Binary Inputs and Outputs

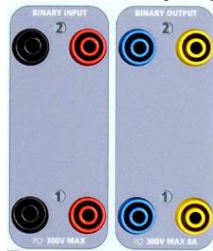

Figure 102 Binary Inputs and Outputs 1 and 2

Binary Inputs and Outputs are clearly marked and logically grouped. The unit's Top Panel will appear different among units, which means Binary Input / Output 1 will always be occupied while Binary Input / Output 2 may, nor may not, depending on the configuration. The 'N' version consists of a system board with only the power and communication ports. The 'P' version adds 8 additional binary inputs, 4 additional binary outputs and a battery simulator. The Binary Inputs are used to monitor relay trip contacts for performing pickup and dropout tests as well as for performing timing functions. The Binary Outputs are used to simulate normally open / normally closed contacts for testing breaker failure schemes, or similar power system operations. In addition they may also be used to switches AC/DC voltages and currents.

⁶ The SMRT33 current channel is the same as the SMRT36 in terms of VA rating and compliance voltage. The SMRT33 current channel is limited to a maximum of 45 Amperes vs. 60 Amperes for the SMRT36.



Figure 103 “P” Option Binary Inputs 3 to 10 and Binary Outputs 3 to 6

1.4.1 Binary Inputs

The binary inputs are specifically designed to measure high speed operation of electro-mechanical, solid-state and microprocessor-based protection relays. All binary Inputs default to Monitor Mode, Contact change of state, latched OFF.

If using the STVI or STVI software to change a binary input from Contact change of state to Voltage Applied / Removed click on or touch the Input Type window and a sine wave will appear where the Contact icon was indicating. The input is now set for voltage sensing.

To change the binary input from Monitor mode to Timer Mode, click on or touch the Use as Monitor button and the display window will change to show Use as Trip, Latched, meaning the binary input is now set to stop the timer upon sensing the first contact closure (if the Input Type is set for contact) or upon sensing voltage if the Input Type is set to Voltage Sensing.

1.4.1.1 Start, Stop, and Monitor Gates

In the SMRT33/36 there are up to ten identical, independent, programmable gate circuits that permit simple selection of the desired mode for timing or contact monitoring operation.

To monitor operation of the contacts or trip SCR in the device under test, a light is provided for each gate. The gate circuit is isolated for voltage-sensing and can monitor solid-state logic signals. Each light will illuminate once contacts close or voltage is applied to the gate.

1.4.1.1.1 Dry Contacts Open

Timer stops or a continuity indicator goes out at the opening of normally closed contacts, or when conduction through a semiconductor device, such as a triac or a transistor, is interrupted.

1.4.1.1.2 Dry Contacts Close

Timer stops or a continuity indicator glows at the closing of the normally open contacts, or upon conduction through a semiconductor device such as a triac or a transistor.

1.4.1.1.3 Application or Removal of AC or DC voltage

This will either start the Timer or stop the Timer. The continuity indicator will glow (application) or darkens (removal) upon the application or removal of either an AC or DC voltage. To serve a wide range of test applications the binary inputs have different voltage thresholds. For typical test applications binary inputs 1 and 2 have a fixed threshold of 5 volts. On the “P” model there are an additional 8 binary inputs. To monitor TTL signals binary inputs 3 through 6 have a fixed threshold of 3 volts. Binary inputs 7 and 8 have fixed thresholds of 5 volts, and binary inputs 9 and 10 have fixed threshold of 30 volts (for “noisy” test environments). A higher threshold voltage helps to eliminate false triggers due to a noisy source. Lower thresholds allow starting and stopping of timer from TTL voltage signals. The allowable voltage applied is 5 to 300 Volts AC or 5 to 300 Volts DC, current limiting resistors provide protection.

1.4.1.1.4 The Timer can be started when turning on any selected generators.

1.4.1.1.5 The Timer can be started simultaneously with a change in Frequency, Phase Angle, or Amplitude. Also, it can be started simultaneously with a Voltage or Current waveform step.

1.4.2 Binary Outputs

Binary Outputs 1 and 2 are located on the top panel, rated for 300 V at 8 Amps. The SMRT33/36 “P” system board option provides four additional Binary Outputs numbered 3, 4, 5 and 6. Each Binary Output can be configured as normally open or normally closed contacts providing logic to the device under test. Binary Outputs 3 and 4 have a rating of 300 V AC/DC, 8 amperes and a maximum of 2000 VA breaking capacity (80 watts DC), with a response time of less than 10ms. Binary Outputs 5 and 6 are high speed and have an AC/DC voltage rating of 400 volts peak, 1 ampere and a response time typically less than 1ms.

The contacts may be programmed to open or close, thus simulating circuit breaker operation. The programmable wait duration is from 1 millisecond to 10,000 milliseconds. A fused test lead (fused at 500 mA) is available as an optional accessory to help protect from blowing the internal fuse of binary outputs 5 & 6. The test lead is blue in color so that the user knows it applies to the blue binary outputs. The barrel holder of the test lead is CE marked with a 1000 V, CAT III rating, and marked FUSED 500 mA / 1000 V/ 50 KA.

1.5 Battery Simulator



The SMRT33 or 36 “P” model includes the battery simulator, and provides a variable DC output from 5 to 250 VDC rated at 100 Watts, 4 Amperes max. User may select from normal setting values of 24, 48, 125, or 250 VDC, or enter the desired output voltage in the window provided, see the STVI Configuration Screen. The output is variable using the STVI Control Knob, or the PC up/down cursor arrows (see 3.5.5 of the STVI section).

Figure 104 Battery Simulator (BAT SIM)



CAUTION:

NOTE: DC voltage is ON and available when the output is turned on using the LCD touch panel or via software command. Do not plug or insert any test lead into the BATTERY SIMULATOR binding posts without first connecting the test leads to the load!

2.0 SETUP

2.1 Unpack System

Unpack the unit and check for evidence of any shipping damage. If there is any visual damage, immediately notify the freight carrier to make a damage claim, and notify Megger of the damage.



CAUTION:

Potentially lethal voltages may be present on the output terminals. It is highly recommended the operator read the user manual thoroughly and have an understanding of the test set operation prior to turning power on.

2.1.1 Initial Start Up

1. With the Ethernet cable supplied with the unit connect the **STVI** Ethernet Port on the SMRT unit to the Ethernet port on the top of the Smart Touch View Interface (STVI). If

using the STVI PC version software, connect the **PC/OUT** Ethernet Port on the SMRT unit to the PC Ethernet port.

2. Before connecting power to the unit, make sure the POWER ON/OFF Switch is in the OFF position (O). Plug the unit line cord into an appropriate power source and turn the POWER ON/OFF Switch to ON (I). As the SMRT unit goes through its power up sequence, in about a minute the STVI power up screen will appear, then the manual start up screen will appear.

2.2 Communication Ports

There are several communication ports. These ports are: one USB, three Ethernet, and an optional Bluetooth wireless port.

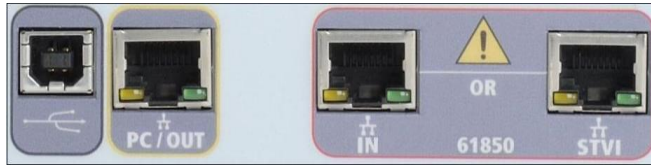

2.2.1 USB 2.0 Interface

USB 2.0 Interface requires a Type B “downstream” connector, and is primarily used as a communication and control port when used with a PC and Megger AVTS or STVI PC version software for automated relay testing. It is recommended that you use the Ethernet port for high speed communication and control of the SMRT unit. To use the USB port will require the user to configure the PC com port for USB operation. Clicking on the Instrument Setup icon on the

PowerDB tool bar , the Instrument Configuration Screen (shown in the following figure)

A screenshot of the 'Instrument Configuration' dialog box. It has a blue title bar with a close button. The main area is light yellow. It contains several text boxes for 'Instrument Use', 'Manufacturer', 'Model/Type/Series', and 'Supported Models'. Below these are dropdown menus for 'Serial Port', 'Baud Rate', 'Byte Size', 'Parity', and 'Stop Bits'. There are also buttons for 'Refresh' and 'Device Manager'. At the bottom, there is a 'Use Ethernet' checkbox, an IP address field (169.254.8.0), and a 'Port' field (8000). At the very bottom are 'OK' and 'Cancel' buttons. A note at the bottom reads: 'Note that USB serial ports can be identified by viewing the serial port list, plugging in the USB port and then hitting the Refresh button. The USB port will be the only new item in the list.'

provides the user with access to the PC Device Manager screen. Click on the Device Manager button and navigate to the USB Ports file directory. Since the SMRT33/36 **defaults to a baud rate of 115,200**, the user will need to configure their USB output com port to match. Returning to

the Instrument Configuration screen the user will need to check off the Use Ethernet check box, and set the Baud rate, Byte Size and Stop Bits as shown.

2.2.2 PC/OUT Ethernet Port

PC/OUT Ethernet Port is a 10/100BaseTX port, and is the primary PC connection port automated relay testing. This port supports MDI/MDI-X auto cross over configuration, which means both standard and “crossover” Ethernet cables may be used. The SMRT comes standard with a crossover cable.

In addition, this port maybe used to download large blocks of data into the unit. It is used to download digital samples for DFR playback, and download software / firmware updates. Since each output channel is capable of storing up to 256,000 samples of Digital Data, such as in Digital Fault Recordings for DFR playback, and with up to six channels that equals over 1.5 million samples. Typically the Ethernet port on the SMRT33/36 should download the data in 1 second or less. In addition to high speed downloads of DFR data, the port is also used to talk to the SMRT33/36 unit via a Network.

This port may also be used to interconnect multiple SMRT units together for synchronous multi-phase operation.

2.2.2.1 Setting SMRT IP Address for Operation with a PC

With the Ethernet cable supplied with the unit, connect the **PC/OUT** Ethernet Port on the SMRT unit to the PC Ethernet port. Turn the test set on. As the SMRT unit goes through its power up sequence, in less than a minute the STVI power up screen will appear. If using the PC version of the STVI software it will auto-detect the SMRT unit connected to the PC. Once it auto-detects the unit, and determines the configuration of the SMRT unit connected, the Manual screen will appear. The unit might not auto detect due to firewall settings. In this case the firewall can be turned off or you can enter the IP address directly using the PowerDB instrument configuration

screen by clicking on the Instrument Setup icon on the PowerDB tool bar . From the Instrument Configuration Screen, shown in the following figure, click off the check mark in the Auto Discover Unit box.

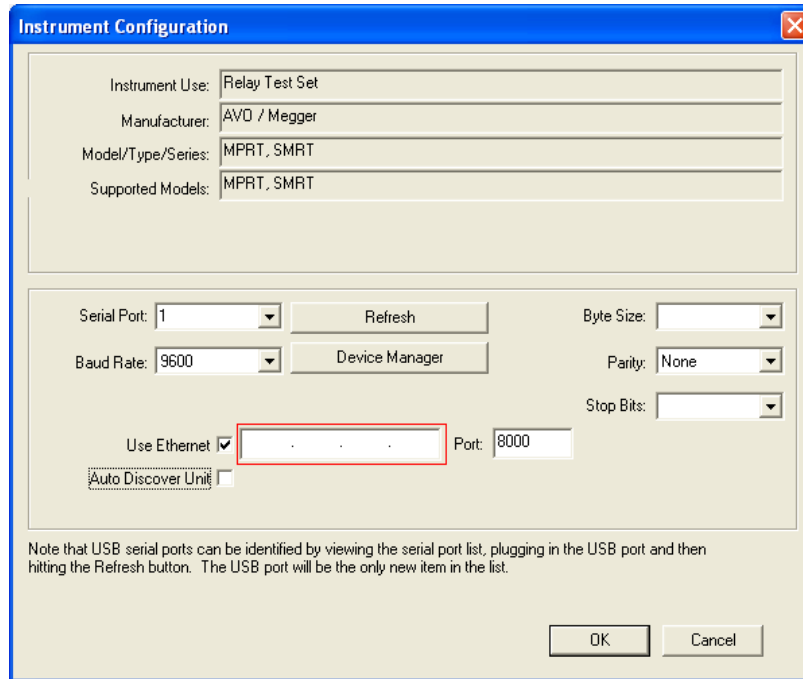

Figure 105 PowerDB Instrument Setup Screen

Here the user can enter the IP address directly into the box highlighted in red. The IP address of the unit can be determined by counting the number of times the Binary Output led flashes at the end of boot up cycle (the address is 169.254. <#flashes>.0). If the unit flashed four times, the address would be 169.254.4.0 . If the unit is on a network with a DHCP server, the user must use the Auto Discovery mode.

2.2.3 STVI Ethernet Port

STVI Ethernet Port is a 10/100BaseTX PoE (Power over Ethernet) port, which is the STVI connection port. This port provides power to the STVI using POE (Power Over Ethernet), and manual control of the SMRT unit with the STVI.

2.2.3.1 Setting SMRT IP Address for Operation with STVI

With the Ethernet cable supplied with the unit, connect the **STVI** Ethernet Port on the SMRT top panel to the Ethernet port on the top of the Smart Touch View Interface (STVI). As the SMRT unit goes through its power up sequence, in less than a minute the STVI power up screen will appear. The STVI will auto-detect the SMRT33/36 (does not require the user to input an IP address). Once it auto-detects the unit, and determines the configuration of the SMRT unit connected, the Manual screen will appear.

2.2.4 IN - IEC61850 Ethernet Port

IN Ethernet Port is a 10/100BaseTX port, and is used when interconnecting multiple SMRT units together. It is also provides access to the substation IEC 61850 network (when enabled). The SMRT33/36 with the IEC 61850 option enabled provides selectable priority, VLAN-ID, and meets the IEC 61850-5 standard Type 1A, Class P 2/3, for high speed trip and reclose simulations.

2.2.4.1 Setting SMRT IP Address for Networks or IEC 61850 Operations



The SMRT33 or 36 maybe controlled over a network. This provides remote control of the SMRT33/36 virtually over any distance allowing one PC to control at least two units simultaneously, such as in end to end testing. *Connecting the SMRT33 or 36 to a Local Area Network or a Wide Area Network could permit unauthorized operation of the unit.*

Through the IN Ethernet port, the SMRT33/36 integrates into a network just like a PC or server. To use this feature requires the user to setup the IP configuration of the SMRT33/36 for their LAN. Note that the SMRT33/36 when turned on will automatically search for and acquire a network address if connected to a network. If it fails to automatically acquire an address check to make sure you are properly connected using a standard Ethernet cable. **Do not** use a “cross-over” Ethernet cable (a cross over cable is designed for use from your PC to the test set, not to a network). If the unit still fails to acquire an address then there may be other issues. This will probably require assistance from your company’s information management department.

For IEC 61850 testing connect the IEC61850 IN port to the substation bus or to the relay under test to receive and send GOOSE messages. When used with the Megger GOOSE Configurator in the AVTS software, the SMRT (when equipped with the IEC 61850 Option) can provide high speed testing of IEC 61850 relays and substations by subscribing to GOOSE messages and mapping to the binary inputs. In addition, it can simulate system conditions such as circuit breaker operation by publishing GOOSE messages mapped to the SMRT33/36 binary outputs. With the PC connected to the OUT port, and running AVTS Megger GOOSE Configurator software, the operator can “sniff” the substation network. However, if a secure port is desired, where the operator cannot accidentally trip off the substation or inflect a PC virus into the substation LAN, connect the PC to the SMRT USB port and sniff the network through the IEC61850 IN port.

3.0 Current Sources

3.1 Parallel Operation

Each SMRT33/36 current amplifier is capable of providing 30 Amperes continuous. The SMRT33 can provide up to 45 Amperes, while the SMRT36 can provide up to 60 amperes for 1.5 seconds for testing instantaneous trip elements. When more than 30 amps single phase is required for long durations, or 60 Amps for testing instantaneous elements, two or three current channels may be connected in parallel to provide 60 or 90 Amperes continuous. For higher output currents three SMRT33 channels can provide up to 135 Amperes, while the SMRT36 can provide 180 Amperes for short durations.

 Note: If an **F** or a **C** appears in the 5th digit of the style identification number (i.e. 30P1**F**0A0S1) the current returns are floating (isolated from each other and ground). Those units with a style number **G** or **E**, the current returns are common together internally and connected to earth ground.

To parallel the current channels of the unit, perform the following:

If using the sleeved multi-lead current test leads (part number 2001-396), all of the black return leads are interconnected together inside the sleeve so they will all share the return current together. Connect each current channel to the relay under test (both red and black terminals to the load). Each Megger test lead is rated for 32 Amperes continuous. If using test leads other than those supplied by Megger insure that the wire has sufficient size to carry the test current.

! For the earth grounded common return (G or C) units, there is an internal common ground between the current channel return terminals. If using separate individual test leads, all of the return leads will need to be common together at the load as shown in the following figure. By not connecting a return lead to all of the current channels in use, part or all of the return current will be forced through the internal ground. That means with a SMRT36 3 channel unit up to 180 Amperes could be forced through the internal common ground, and may cause damage to the internal common returns. Therefore, it is important that the parallel connections must be made at the relay. See the following figure.

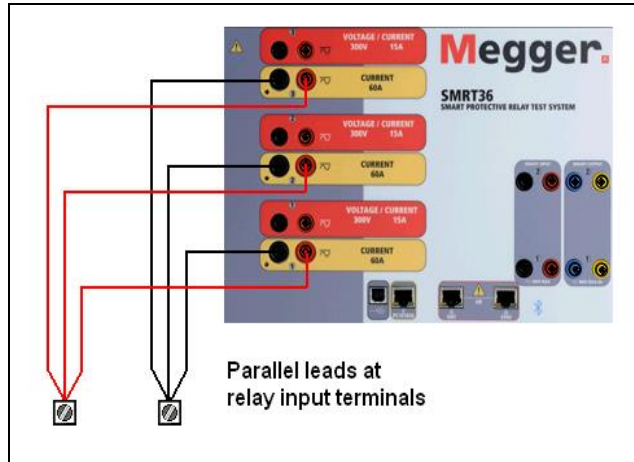

Figure 106 Parallel of All Three Current Outputs

3.1.1 Manual Test Screen - Single Phase Up To 180 Ampere⁷

For ease of use and operator convenience, go to the Configuration screen and select the Operating Mode of **3 Voltages – 1 Current @ 180 amps**. When you return to the manual test screen there will be one current channel displayed, as shown in the following figure.

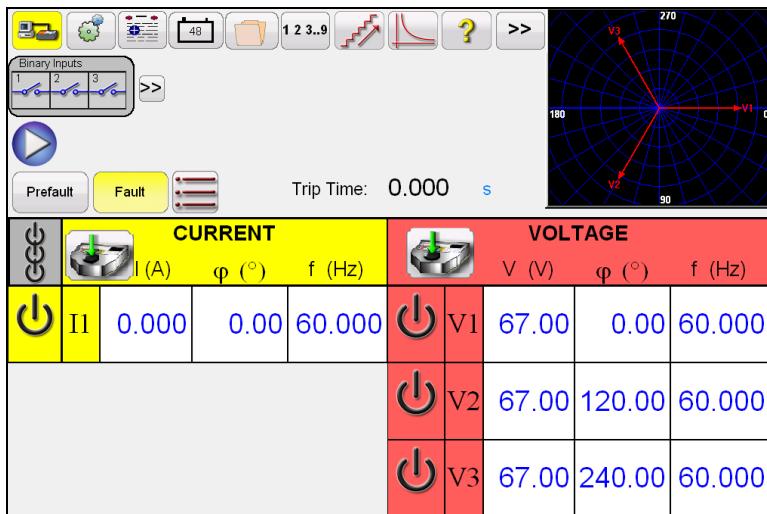

Figure 107 Manual Test Screen – SMRT3X Single Phase Operation

⁷ The SMRT33 screen will look identical with the exception of a limited maximum output current of 135 Amperes vs. 180 Amperes in the SMRT36.

The STVI will automatically set all three currents in phase with each other and divide the current equally between the three current amplifiers. When setting an output, simply enter the value of the desired output current. For example, for an output of 75 Amperes, enter 75, while each current amplifier will be providing 25 Amperes. The current can also be phase shifted. Simply enter the desired phase angle and all three currents will be phase shifted together.

If two current channels that are to be used in parallel, leave the unit in the default three phase configuration. Connect the two current outputs to the load as shown in the following figure.

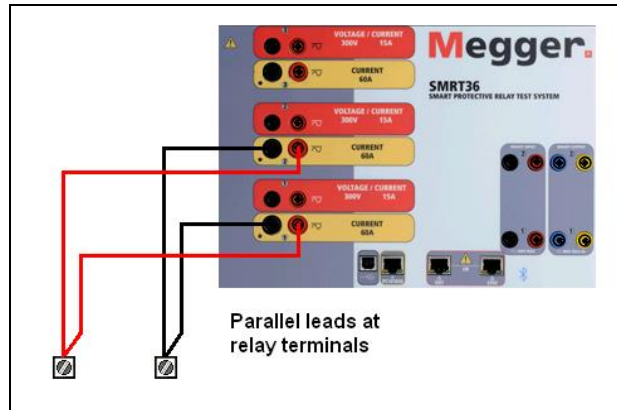



Figure 108 Two Currents in Parallel

Set each channel to one-half of the output requirement. Be sure and reset current channel #2 to 0 degrees so that it will be in-phase with current channel #1. With both current channels selected, turn output on by pressing or clicking on the ALL ON/OFF button. Always use the ALL ON/OFF button to turn both current channels on and off together. For manually ramping outputs, if using the PC version of the STVI software the $\uparrow\downarrow$ buttons will be displayed. If using an STVI controller the Control Knob icon  will be displayed. Pressing either of these two will present the user with a window to select the desired level of increment for manually ramping the outputs, the desired channel(s) to be ramped, and what is to be adjusted (amplitude, phase angle or frequency).

3.2 Currents in Series Operation

Two current channels may be connected in series in order to double the available compliance voltage. High impedance electromechanical ground (earth) overcurrent relays have always been difficult to test at high multiples of tap due to the winding impedance and saturation characteristics. The peak voltage required can exceed the maximum output voltage of one SMRT33/36 current output channel, depending on the required test current. By connecting two current outputs in series, the compliance voltage is doubled, providing higher test currents through the load. There are two methods to series currents together. For the floating output (F or C) models connect the two current amplifiers in a “push-push” configuration as shown in the following figure.

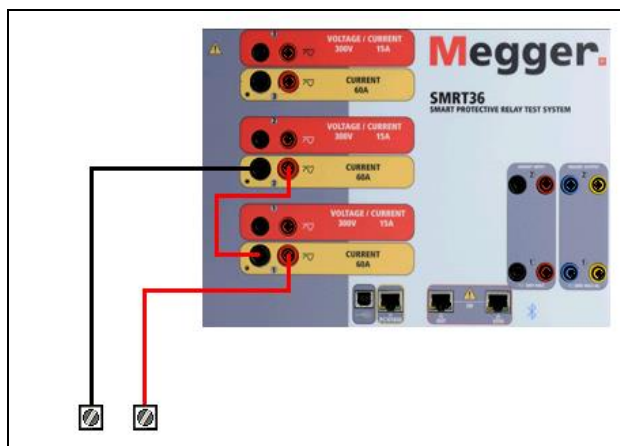



Figure 109 Series Two Currents with Floating Output Unit

The two current channels that are to be used in series set each to the same test current magnitude, and phase angle. Select both current channels and turn output on by pressing or clicking on the ALL ON/OFF button. Always use the ALL ON/OFF button to turn both current channels on and off together. For manually ramping outputs, if using the PC version of the STVI software the \updownarrow buttons will be displayed. If using an STVI controller the Control Knob icon  will be displayed. Pressing either of these two will present the user with a window to select the desired level of increment for manually ramping the outputs, the desired channel(s) to be ramped, and what is to be adjusted (amplitude, phase angle or frequency).

To series the current channels of the common grounded returns (G or E) unit, perform the following:

Using the current channel test leads, connect the Red output terminals of the two current channels to the relay under test. Even though the two returns associated with the current channels are connected internally with the common returns, place a jumper as shown. This will insure that the internal common leads will not be damaged.

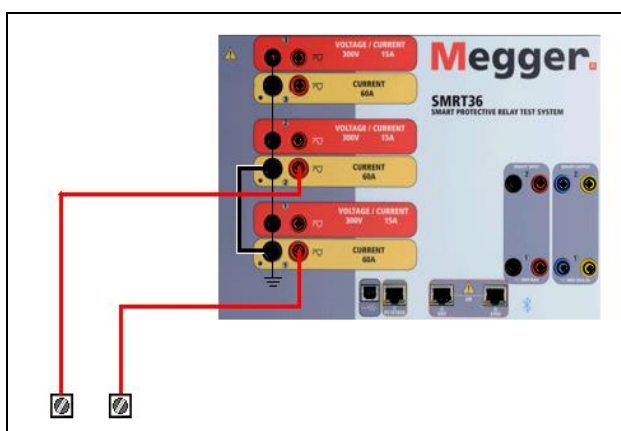



Figure 110 Series of Two Current Channels with Grounded Common Returns

! NOTE: One current channel should be set to 0 degrees and the other current channel should be set to a phase angle of 180 degrees so that the two compliance voltages add across the load. DO NOT attempt to series more than two currents together on a grounded common returns unit.

The two current channels that are to be used in series set each to the same test current magnitude. Initiate the two current channels simultaneously by pressing the ALL ON/OFF button.

Always use the ALL ON/OFF button to turn both current channels on and off together. For manually ramping outputs, if using the PC version of the STVI software the \updownarrow buttons will be displayed. If using an STVI controller the Control Knob icon  will be displayed. Pressing either of these two will present the user with a window to select the desired level of increment for manually ramping the outputs, the desired channel(s) to be ramped, and what is to be adjusted (amplitude, phase angle or frequency).

4.0 Voltage Sources

4.1 Outputs Summed Together

Two voltage channels may be used to sum the voltage outputs to obtain higher than rated voltage provided the load is ungrounded. Connect the load between the voltage channel posts, set V_1 Phase to 0° and set V_2 Phase to 180° . The voltage outputs will add so the total voltage is the sum of the two voltage amplitudes, V_1 and V_2 as can be seen in the following figures.

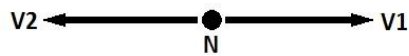

 Note: If an **F** or **C** appears in the 5th digit of the style identification number (i.e. 30P1**F**0A0S1) the voltage returns are floating (isolated from each other and ground). Those units with a style number **G** or **E** the voltage returns are common together internally and connected to earth ground.

For the floating common units the user must connect the associated voltage channels black common returns together, when series operation is required (see the following figures). Remove external commons when testing is completed. DO NOT attempt to series more than two voltage channels together.

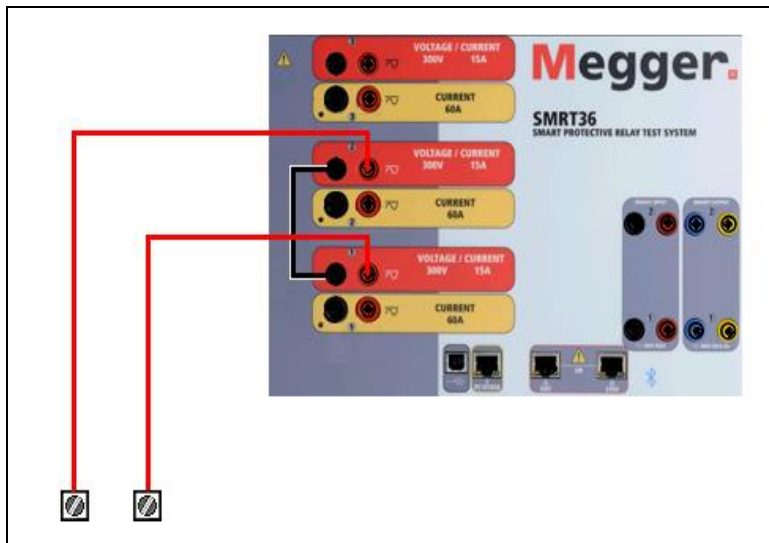

Figure 111 Series of Voltage Channels for **Floating Ungrounded Common Returns**

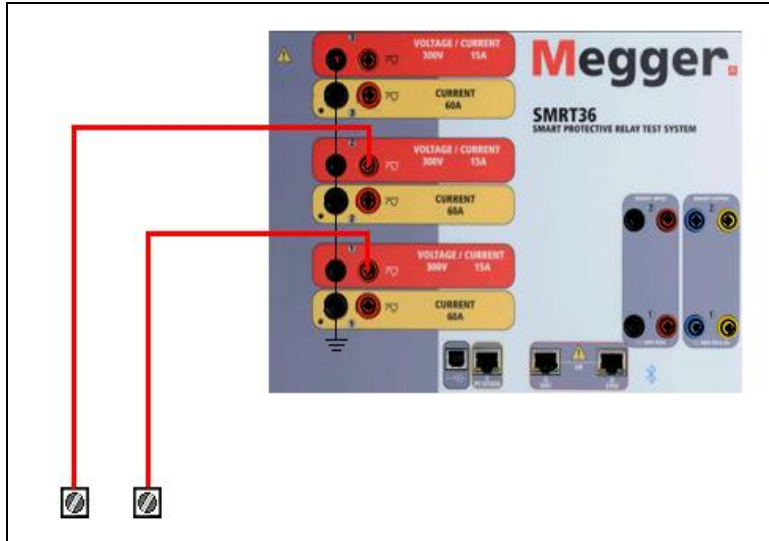

Figure 112 Series of Voltage Channels **with Grounded Common Returns**

4.2 3Ø, 3-Wire, Open-Delta and T-Connection

4.2.1 Balanced Open Delta

Two methods of obtaining a three-phase, three-wire voltage source are available. The Open-Delta configuration is the easier to use when a balanced three-phase source is required because the amplitude and phase relationship can be set directly. No calculations are necessary.

When using the Open-Delta configuration, it is suggested to use voltage channel #1, designated V_1 , and voltage channel #2, designated V_2 , while the COMMON binding post is designated V_g . With this arrangement, the magnitude and phase angle of the potentials can be easily calculated and set. For the balanced three-phase condition V_{1g} and V_{2g} are equal in magnitude and separated by an angle of 60° . This is done by setting the V_1 and V_2 potentials equal in magnitude, setting 0° on V_1 and 300° (60 degrees leading assuming that the default phase rotation is set to 360 Lag) on V_2 , see the following figures.

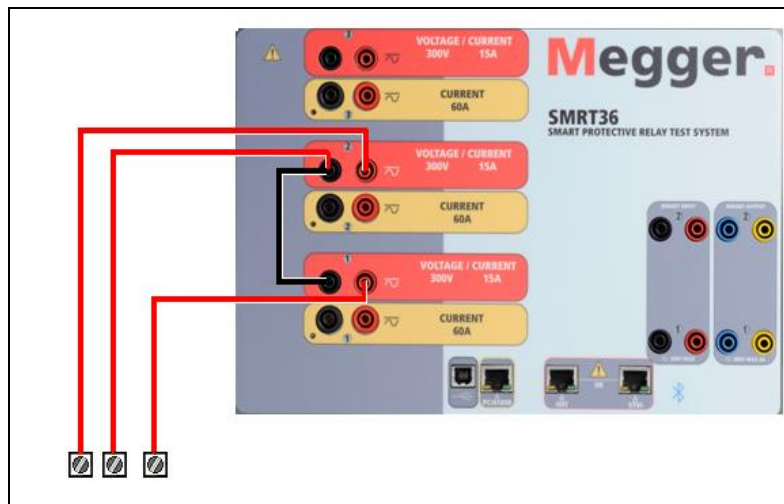
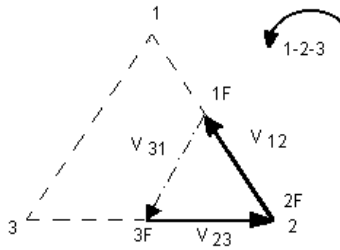

Figure 113 Three Phase Open Delta Connections

When using the Open-Delta Configuration to set up a phase-to-phase fault, calculations' using the Law of Cosines is required to calculate amplitude and phase relationships. (See discussion under T-Connection for simulating unbalanced, phase-to-phase faults without need for calculations.)



Balanced 30 - Open Delta Connection

If V_f equals the desired test potential, then:

Set $V_1 = V_f \angle 0^\circ$

Set $V_2 = V_f \angle 300^\circ$ Lagging (60° Leading)

Rest of page intentionally left blank.

4.2.1.1 Unbalanced Open Delta

When setting up an Unbalanced Open-Delta configuration, the desired phase-to-phase fault voltage, V_{1f} is set using voltage channel #1 with its phase angle set to 0° . Phase-to-phase voltage V_{2f} and its phase angle relationship for voltage channel #2, must be calculated using the Law of Cosines; where For any triangle the following formula applies:

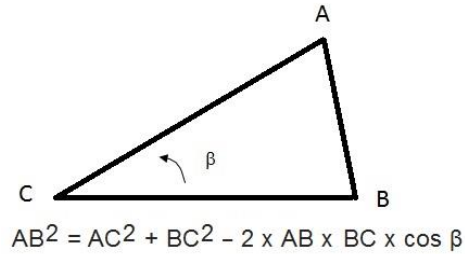

The next figure shows the phase relationships between voltages and an example of the necessary calculation. For convenience the amplitude and the phase angle settings for the typical V_f fault magnitudes are tabulated.

From the Law of Cosines

$$\theta = \arccos\left(\frac{V_{12}}{2 * V_{23}}\right)$$

$$V_{23}^2 = \left(\frac{V_{12}}{2}\right)^2 + \left(\frac{\sqrt{3}}{2} * 120\right)^2$$

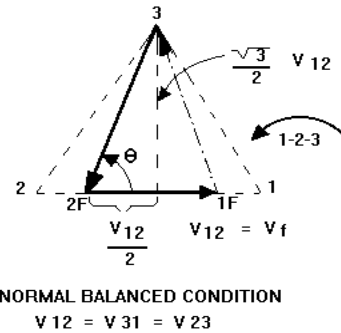

Figure 114 Open-Delta Unbalanced phase-to-phase Fault Voltages

Settings for Typical Phase-to-Phase Fault Voltages

$$V_{12} = V_{\text{fault}}$$

V_{12}	1	5	10	15	20	25	30	35	40	45	50	55	60	65	70
V_{23}	104	104	104	104	104	105	105	105	106	106	106	108	108	109	110
At 0° Lag	270	271	273	274	275	277	278	280	281	282	284	285	286	287	289

4.2.2 T Connection

The second method of obtaining a three-phase, three-wire voltage source is the so-called T-Connection. The method, shown in the following figure, is easier to use when obtaining an unbalanced, phase - to -phase fault simulation since it eliminates calculations. To reduce confusion when using the T-Connection, the voltage output #1 is designated V_a and its phase angle set at 0° , voltage output #2 is designated V_b and its phase angle set for 180° , and voltage output #3 is designated V_c and its phase angle is set for 270° . Any combination of balanced three phase faults or unbalanced phase-to-phase fault conditions can be easily simulated. The following figure indicates these phase relationships.

! NOTE: This method should not be used for very low fault voltages, or used on solid state relays that may be sensitive to this type of connection (i.e. 5 volts or less, or for testing ABB or Westinghouse type SKD relays).

$$V_f = \text{Desired Fault Voltage}$$

$$V_a = \frac{1}{2}V_f \angle 0^\circ$$

$$V_b = \frac{1}{2}V_f \angle 180^\circ$$

$$V_c = \frac{\sqrt{3}}{2} 120 \text{ or } V_c = 104V \angle 270^\circ$$

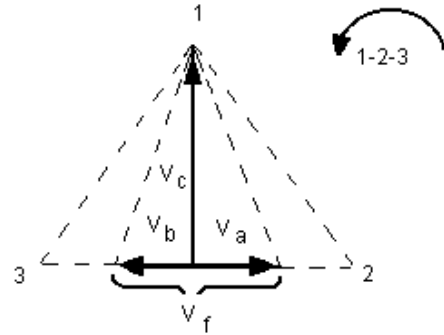

Balanced or Unbalanced Fault T-Connection

4.3 3Ø, 4-Wire, Y-Connection

A three-phase, four-wire potential system can be provided using three output modules. The vector relationships are referenced below. This Y-Connection has the advantage of being able to supply a higher line-to-line voltage ($1.73 \times$ phase-to-neutral voltage). It is ideally suited for simulating phase-to-ground faults. Voltage channel #1 is designated as V_a with its phase relationship set for 0° . Voltage channel #2 is then designated as V_b and phase angle set for 120° . Finally, voltage channel #3 is designated V_c and phase angle set for 240° (for a 1-2-3 counter clockwise rotation). V_a , V_b and V_c are connected to the voltage potential binding posts on the respective test sets.

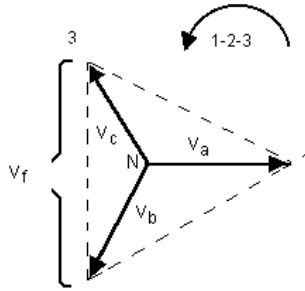

Balanced 3 ϕ , 4 Wire Y-Connection

$$V_f = \text{Desired Fault Voltage}$$

$$V_a = \frac{\sqrt{3}}{3} V_f \angle 0^\circ$$

$$V_b = \frac{\sqrt{3}}{3} V_f \angle 120^\circ$$

$$V_c = \frac{\sqrt{3}}{3} V_f \angle 240^\circ$$

!Note: If an **F** or **C** appears in the 5th digit of the style identification number (i.e. 30P1**F**0A0S1) the voltage returns are floating (isolated from each other and ground). Those units with a style number **G** or **E** the voltage returns are common together internally and connected to earth ground.

If using the sleeved multi-lead voltage test leads (part number 2001-395), all of the black return leads are interconnected together inside the sleeve so they will all share the return together. Therefore, only one return lead is provided on the relay connection side of the sleeved leads (similar to the connections in the following figure).

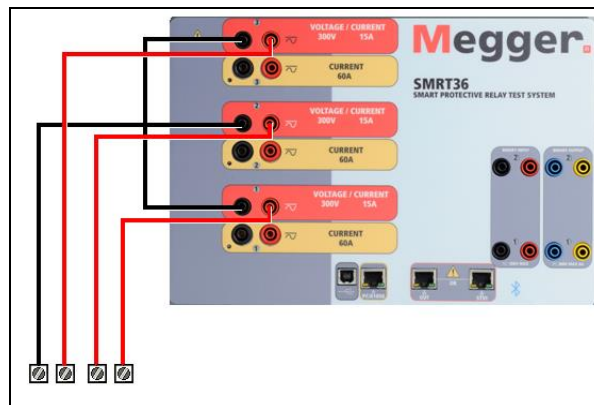

Figure 115 Three Phase Four Wire Test Connections

!For the earth grounded common return (**G** or **E**) units, there is an internal common ground between the voltage and current channel return terminals. Therefore, only one return lead is

required for the voltage channels. If using separate individual test leads, for the floating common units the user must connect the associated voltage channels black common returns together as shown above.

5.0 Warranty Statement

Megger warrants the product is free of defects in material and workmanship for a period of one (1) year from date of shipment. This warranty is non-transferable. This warranty is limited and shall not apply to equipment that has damage, or cause of defect, due to accident, negligence, and improper operation, faulty installation by the purchaser, or improper service or repair by any person, company or corporation not authorized by Megger. Megger will, at its' option, either repair or replace those parts and/or materials it deems to be defective.

The warranty is in lieu of all other warranties, either expressed or implied on the part of Megger and in no event shall Megger be liable for the consequential damages due to the breach thereof.

5.1 Preventive Maintenance

The unit utilizes surface mount technology (SMT) and other components which require little or no service except for routine cleaning, etc. The unit should be serviced in a clean atmosphere away from energized electrical circuits.

5.1.1 Examine the unit every six months for:

Dust and Dirt	To clean the unit, disconnect the power cord from the unit. Never use spray liquids or industrial cleaners. Some cleaning solvents can damage electrical components, and should never be used. Water and a mild soap may be used. Use a lightly damp cloth (not dripping wet) to wipe off the unit. A dirty heat sink can cause thermal overloads. Remove dust with dry, low pressure, compressed air. Either remove the module from the chassis or simply apply air forcing the dust away from the heat sink through the sides of the unit.
Moisture	Remove moisture as much as possible by putting the test set in a warm, dry environment.

5.1.2 Updating SMRT33/36 Firmware

Download Firmware Upgrade via Megger Website

To download the newest firmware from the Megger website,

1. Go to WWW.Megger.com
2. **Log In.**
3. Go to **Software Downloads**
4. Click on **SMRT**
5. You will see instructions to enter the serial number of the SMRT unit, and then click on **Continue**. The serial number is 12 digits long. Make sure you enter all 12 digits. Then click on **Firmware Version #.##**. The firmware will be downloaded onto your PC as a zip file. Unzip the file, **Select All** files, and **Copy** to a USB memory stick, or create a file on your PC for storage to unzip or extract to a file.

USB Memory Stick: With the SMRT and STVI powered up, insert the USB memory stick into the USB port on top of the STVI. Press the **Configuration** Screen button, and then press the **Update Firmware** button in the Configuration Screen. At that point the user will be presented with the IP Address selection screen, with the serial number of the unit. Select the unit by touching the serial number and the upgrade process will automatically start. That's all there is to it. Observe the STVI display screen, and the unit. At the completion of the download, the user will note the fans spin-up, and the LED's will be flashing rapidly on the SMRT unit. There will be an instruction to reboot (turn off and back on) the test system.

PC and STVI Software: If using the PC version of the STVI software, it is very similar to the STVI. Upon clicking on the Update Firmware button, the familiar Windows *Open File* browser dialog box will appear. Using the *Look In* pull-down menu, navigate to where the new firmware was downloaded onto the PC, click on and open the file folder SMRT_LDR (SMRT Loader). There you will find the new firmware file. Click on the file, and click on Open. You will be requested to select a unit from the IP Address screen. Select the unit by clicking on the serial number and the upgrade process will automatically start. At the completion of the download, the user will note the fans spin-up, and the LED's will be flashing rapidly on the SMRT unit. There will be an instruction to reboot (turn off and back on) the test system. Note that after rebooting the SMRT unit, if using the PC version of the STVI software you will have to restart the STVI software on your PC in order to regain control of the SMRT unit.

5.2 Service and Repair Instructions

To save turn-around time and reduce costs, SMRT33/36 was designed as a modular unit. In most cases, if any one module should experience a problem it should not cause the test system to be down. Basic troubleshooting information has been provided to guide the technician to the possible source of a problem.

Since SMRT33/36 uses Surface Mount Technology, most repairs of the individual modules are beyond the scope of the basic troubleshooting guide, and should be referred to the Service Department at Megger or handled through the Megger Representative.

 If the unit is still within the original warranty period, or limited warranty period following factory servicing, **the factory must be contacted before attempting any repairs or the warranty will be void.**

5.2.1 Basic Troubleshooting

The troubleshooting information relies on the technician to have a good understanding of the operation of the unit. If the technician is unfamiliar with the unit, he or she should not attempt to repair. The technician should contact the factory before attempting repairs. Provide the Megger part number for the part or assembly in question and the serial number of the SMRT33/36 when making inquiries.



WARNING It is necessary to energize the SMRT33/36 to properly troubleshoot some of the modules. The technician must take all applicable safety precautions for working near energized circuits.

NOTES

Before suspecting a failure in the SMRT33/36, review the General Description and Operation sections to ensure that the problem is not a result of operating error.

Preliminary testing of the SMRT33/36 within its specified limits can help determine if a malfunction actually exists, identify the type of malfunction and define the general area of the failure.

Common causes of malfunctions, other than improper operation, are incorrect power input (voltage above or below specified limits), incorrect test signal voltages applied to the Binary Input gates (outside of the specified AC/DC Applied/Removed limits), and contact or circuit resistance too great for the Dry Contact gates to operate properly on the Monitor/Start/Stop gates. Typical malfunctions for the VI-Gen amplifiers are external short circuits on the voltage output and open circuits on the current output. The battery simulator and VI-Gen voltage and current outputs can be easily checked using a voltmeter and ammeter.

 **NOTE:** There are three different modules that make up a SMRT33/36; the System Board (front panel), VIGEN'S (VIGEN#1, and #2) and VIGEN LITE (VIGEN #3). Most problems can be easily resolved by replacement of one of these modules, see section **5.2.1.2.1 Replacing a VIGEN** for instructions on how to replace a VIGEN module. Proper ESD procedures should be followed when handling any SMRT33/36 module. Failure to do so, may damage sensitive parts.

5.2.1.1 Power Input

Input voltage affects the whole unit and may or may not cause permanent damage if voltage is incorrect. These problems can often be corrected by simply using a better source of input power. For units with an **F** or **G** appearing in the 5th digit of the style identification number (i.e. 30P1**F**0A0S1) the rated voltage limit is auto-selectable from 100 to 240 volts, $\pm 10\%$, 47 to 63 Hz. For units with a **C** or **E** appearing in the 5th digit of the style identification number (i.e. 30P1**C**0A0S1) the rated voltage limit is auto-selectable from 220 to 240 volts, $\pm 10\%$, 47 to 63 Hz.

Some symptoms are as follows:

1. Low voltage: Erratic operation, no output, input power circuit breaker operation.
2. High voltage: Circuit breaker operation, power supply failure in Input Power Module.

5.2.1.2 VIGEN Input Power, Communication and Control

Basic troubleshooting of the input power is as follows.

1. No power: Check the ON/OFF circuit breaker. Does the ON/OFF switch light up? If it does not light up, then power is not getting to the unit. Check power source and line cord. If it lights up then the power is getting to the unit. Check the VIGEN power cable connection.



CAUTION: Turn off main power and unplug line cord before attempting to work on any module. Observe proper Electro Static Discharge procedures.

- A. Disconnect the power cord from the unit.
- B. Remove the two Phillip head screws on each side hold on the top cover; the first top screw and the fourth screw, see the following figure.

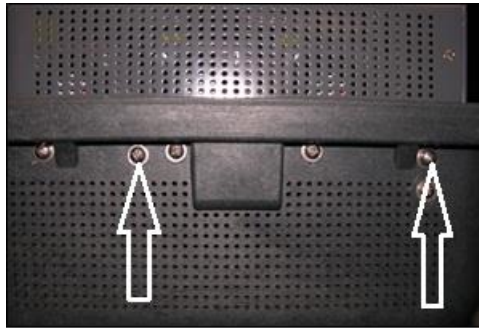

Figure 116 SMRT33/36 Top Cover Securing Screws⁸

- C. Remove the front center screw on the front panel, and the two screws (one on each side) of the top cover that connects the top cover to the front panel, see the following figure.

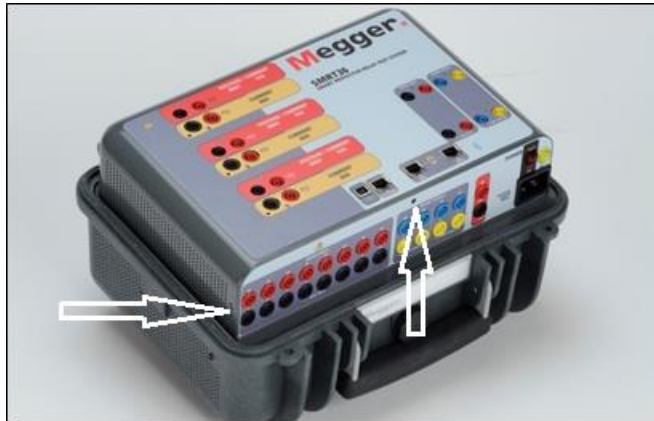

Figure 117 Top Panel Removal Front Panel Screws

- D. To remove the top cover from the enclosure will require an awl, or a small nail punch, and hard flat plastic wedge (like a plastic ruler). Cover the enclosure lip and ridge with the plastic ruler to prevent damage to the enclosure ridge. Place the awl into a vent hole and leverage the cover up slightly on each side, see the following figure.

⁸ The number of screws that appear of the sides may vary depending on the configuration and design of the top cover (units beginning in 2012 have a different top cover design).

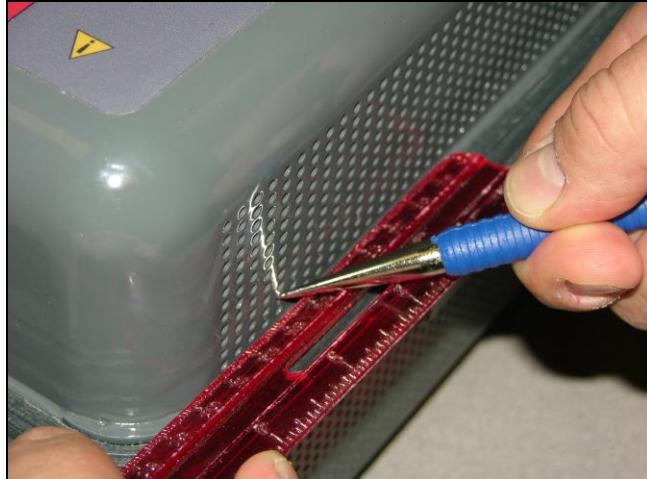

Figure 118 Leveraging the cover from the enclosure

Continue to alternately leverage the cover up until you can work the cover out with your hands by grasping the back of the cover with one hand and gently, yet firmly, pull the cover up from the unit slightly. Then, alternately move the front side up slightly working the cover out of the enclosure. It is tight fit so work slowly and carefully.

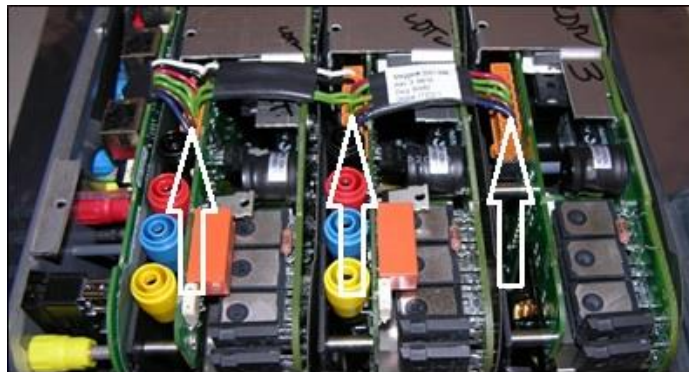

Figure 119 VIGEN Power Connectors

Check the cables as shown. If the cables are properly connected, then remove and replace the VIGEN per 1.5.2.1.2.1.

2. Erratic Manual Control

Individual Output Module communication cable is not properly connected thus cannot receive proper commands. Look through the air intake holes on the left side of the unit to observe the VI-Gen LED's. Each module has some green LED's that blink. These are associated with the Ethernet communications. If there are no blinking LED's on one or more modules, then the module is not communicating. Remove the top cover using the procedure described above.



CAUTION: Turn off main power and unplug line cord before attempting to reseat any cables. Observe proper ESD procedure.

Locate the communication Ethernet cables on the left side, see the following figure.



Figure 120 Communication Cable Connections

Carefully disconnect each cable and reconnect to insure the cable locks into position. Note: In order to reseal each communication cable the small wire-ties will need to be removed (replacement wire-ties will be required after reseating the cables).



CAUTION: Failure to replace wire-ties may pinch the communication cables upon replacement of the top cover.

After reseating the cables, reinstalling the top cover assembly, reconnect the power cord and power up the unit. Look through the air intake holes on the left side of the unit to observe the VI-Gen LED's. If there is still no blinking LED's on one or more modules, and then replace the VI-Gen Module(s) that are not communicating. If they are not lit, then remove the power cord and the top cover and check the power connection cables to each VIGEN as described in Step 1 above.

5.2.1.2.1 Replacing a VIGEN

1. To remove the VIGEN, on early units there are three Phillip head screws that hold in the VIGEN, one on each side and one on the bottom of the unit. Newer generation units only have one screw on the bottom.
2. Remove the power connection cable as shown in Figure 73 above.
3. Disconnect the communication cables as described for Figure 74 above.

- ⓘ Note the small cable that connects the front panel board to VIGEN 1 needs to be carefully removed prior to removing VIGEN1, see the following figure.



Figure 121 VIGEN1 to Front Panel Cable

4. Carefully remove the VIGEN module from the chassis.
5. Install replacement VIGEN.



Be careful when replacing the module as it is a tight fit, and it is possible to damage components upon extraction or installation.

6. Replace the Phillip head screw(s) that hold in the VIGEN.
7. Reconnect the power connection cable as shown in Figure 89 above.
8. Reconnect the communication cables as shown in Figure 90 above. Replacement wire-ties will be required after reseating the cables.



CAUTION: Failure to replace wire-ties may pinch the communication cables upon replacement of the top cover.

9. If VIGEN #1 was replaced, reconnect the front panel cable as shown in Figure 91 above.
10. Reinstall the top cover. Reconnect the power cord and power up the unit.

5.3.1.3 Binary Inputs, Binary Outputs and Battery Simulator (P Option Unit)

If all the items external of the Timer assembly are in proper order, then the problem exists within the Binary Input / Output assembly itself.

Some basic troubleshooting can pinpoint problems to the approximate cause.

Binary Inputs - Basic troubleshooting is as follows:

1. Timer does not stop:
Jumper the appropriate Binary Input terminals manually. If LED above the selected input lights, check the Binary Input setup screen to verify that the selected binary input is properly setup as a Timer stop post. Check Timer stop settings as N.O. (Normally Open) to close, and Latch On. If LED does not light up, the Binary Input will need to be repaired or replaced.
2. Counting errors:
AC applied or removed Stop signals can create, what appears to be poor repeatability, an inaccuracy or a malfunction in the Timer. The lower the voltage level, the more serious the "error" will be. What appears to be an error, however, is actually a variation in the point on the sine wave at which the voltage is great enough to cause the gate circuit to operate. If the circuit used for the timing test has a low AC voltage and the point at which the contact in the test circuit opens or closes, is at or close to zero on the sine wave, the period of time before the voltage level will be high enough to trigger the gate circuit can be as much as 4 milliseconds. The total timing variation can be as much as 8 milliseconds. The shorter the duration of the timing test, the more significant the variation becomes. Therefore, if small timing variations would present a problem, it is recommended that an AC voltage of 115 volts or above or a DC voltage be used for voltage applied/removed test selections.

When the SMRT33/36 Timer calibration is being tested, the AC voltage variable is often overlooked. This is particularly true when the Timer is compared to a counter and the two are triggered simultaneously with an electronic switch. For best results, a DC voltage should be used to eliminate the variable. If testing the AC voltage Timer Stop characteristics is desired, then the Stop signal must be triggered at the same point on the sine wave to assure that the gate signal will be repeatable. Ideally, the signal should be

at a point near peak in the positive direction. In addition, the specified rms AC voltage values for the various Stop control selections must be adhered to.

Another source of apparent "error" can be the programmable de-bounce feature. If using electro-mechanical contacts for stopping the Timer, and if those contacts have a tendency to bounce, there could be a difference between an external standard timer and the SMRT33/36 Timer, depending on the programmed de-bounce period set in the SMRT unit. To determine the programmed value, look at the Binary Input Setup Screen and see what the De-bounce setting value is.

If a timing error or variation persists after all the suspected causes of error have been eliminated, then it is possible that the Binary Input circuit is malfunctioning. Contact factory for return instructions.

Binary Outputs - Basic troubleshooting is as follows:

Binary Output LED is ON but output contacts **not closed**:

Using a continuity tester check to see if output circuit is open circuited. If circuit is open then it is possible that the internal surface mounted fuse element has been blown. Note: an optional in-line fused test lead Part Number: 568026 are available to provide protection from switching too high current, see SMRT Ordering Information under Optional Additional Accessories. The unit will need to be returned to the factory for further inspection and repair.

 Contact the factory for a Repair Authorization Number and return instructions if service is required. A Repair Authorization (RA) number will be assigned for proper handling of the unit when it arrives at the factory. Any non-warranty repair cost incurred for the repair or replacement of parts and/or materials shall be the responsibility of the purchaser.

Provide the factory with model number, Unit serial number, serial number of VI-Gen if appropriate, nature of the problem or service, return address, your name, and how to contact you should the factory need to discuss the service request.

You may need to provide a purchase order number, cost limit, billing, and return shipping instructions. If an estimate is requested, provide the name and contact information.

6.0 Preparation for Reshipment

 Save the original shipping container for future use. The shipping container is designed to withstand the rigors of shipping via a common commercial carrier. For example, you may wish to reship your unit to Megger for an annual calibration recertification.

Pack the equipment appropriately to prevent damage during shipment. If a reusable container is utilized, the unit will be returned in the same shipping container if it is in suitable condition.

Add the Return Authorization Number to the address label of the shipping container for proper identification and quicker handling.

 **NOTE:** Ship the equipment without nonessential items such as test leads, etc. These items are not needed by the factory to perform service.

Megger[®]

Addendum C













* SMRT410 shown with DIGEN and "P" Plus options

Model SMRT410 **Megger Relay Tester**

SAFETY PRECAUTIONS

WARNING: VOLTAGES GENERATED BY THIS INSTRUMENT CAN BE HAZARDOUS

This instrument has been designed for operator safety; however, no design can completely protect against incorrect use. Electrical circuits are dangerous and can be lethal when lack of caution and poor safety practices are used. There are several standard safety precautions that should be taken by the operator. Where applicable, IEC safety markings have been placed on the instrument to notify the operator to refer to the user manual for instructions on correct use or safety related topics. Refer to the following table of symbols and definitions.

Symbol	Description
	Direct Current
	Alternating Current
	Both direct and alternating current
	Earth (ground) Terminal. There is a common chassis ground terminal located on the front panel (see Front panel under Description of Controls).
	Protective Conductor Terminal
	Frame or Chassis Terminal
	On (Supply)
	Off (Supply)
	Caution, risk of electric shock
	Caution (refer to accompanying documents)

WARNING: Under no circumstances should the operator or technician attempt to open or service this instrument while connected to a power source. Lethal voltages are present and may cause serious injury or death!

SAFETY PRECAUTIONS (Continued)

The following are some specific safety related items associated with the SMRT test system.

Read and understand all safety precautions and operation instructions before attempting to use this unit.

The purpose of this equipment is limited to use as described in this instruction manual. Should a situation arise that is not covered in the general or specific safety precaution please contact Megger regional representative or Megger, Dallas Texas.

Safety is the responsibility of the user. Misuse of this equipment can be extremely dangerous.

Always start with the power OFF, before connecting the power cord. Make sure outputs are off before attempting to make test connections.

Never connect the test set to energized equipment.

Always use properly insulated test leads. The optional test leads are rated for the continuous output ratings of the test system, and should be properly used and cared for. DO NOT use cracked or broken test leads.

Always turn the test system off before disconnecting the power cord.

DO NOT attempt to use the unit without a safety ground connected.

DO NOT attempt to use the unit if the power cord ground prong is broken or missing.

DO NOT use the test set in an explosive atmosphere.

The instrument must only be used by suitably trained and competent persons.

Observe all safety warnings marked on the equipment.

For safety related or other important topics, like the statement below, will be notated with the adjoined symbol. Read the topic carefully as it may relate either to the safe operation of the test system or the safety of the operator.



Under no circumstances should the operator put their hand or tools inside the test system chassis area with the test system connected to a power source. Lethal voltages are present and may cause serious injury or death!

1.0 Operation

The unit's design is a "modular" concept. All inputs and outputs are clearly marked and logically grouped so continual reference to the instruction manual should not be necessary once the operator is acquainted with the test system. The unit's Top Panel will appear different among units, since each unit may have up to three optional Voltage/Current Generator (VIGEN) Modules installed. The 'N' version consists of a system board with only the power and communication ports. The 'P' version adds 8 additional binary inputs, 4 additional binary outputs and a battery simulator.

1.1 General Description

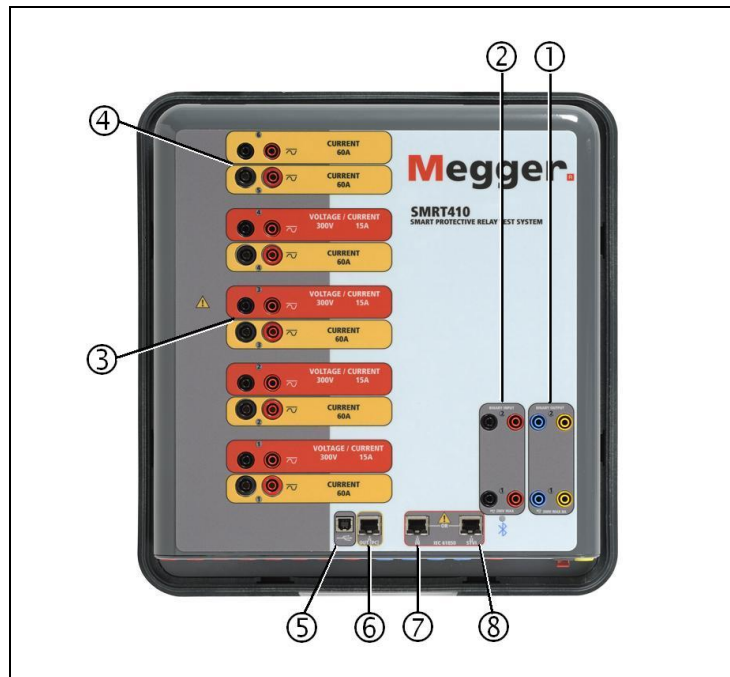

Figure 122 Top Panel SMRT410 (Pictured with Floating Returns and DIGEN Options)

1.1.1 Top Panel

1. **Binary Outputs** – the first two VIGEN modules include Binary Inputs and Binary Outputs. Therefore, with a minimum 2 channel unit there are 2 Binary Outputs located on the top panel (numbered 1 and 2). More Binary Outputs are available with the P option see Front Panel section for more information. Each Binary Output can be configured as Normally Open or Normally Closed contacts providing logic to the device under test. The Top Panel Binary Outputs can switch up to 300 VAC or 250 VDC with 8 Amp continuous. The programmable wait duration is from 1 millisecond to 10,000 milliseconds.
2. **Binary Inputs** – with a minimum 2 channel unit there are 2 Binary Inputs located on the top panel. More Binary Inputs are available with the P option see Front Panel section for more information. The Binary Inputs will accept a voltage range of 5 to 300 VAC, or 5 to 250 VDC, or dry Normally Open / Normally Closed contacts.
3. **Voltage/Current Generator Module (or VIGEN)** – There are four available slots for the VIGEN Modules. The slots are numbered 1 to 4 from bottom to top, with the topmost VIGEN numbered 4. The four voltages and currents are noted by the red and yellow surrounding each output channel. Phases A, B, C and D Voltage Channels (V1, V2, V3

and V4) are denoted by the red color. Phases A, B, C and D Current Channels (I1, I2, I3 and I4) are denoted by the yellow color. When the voltage generators are converted to current generators, they will change on the STVI display as V1 = I5, V2 = I6, V3 = I7, and V4 = I8. For more details on the VIGEN output capabilities see section 1.4.

4. **Current/Current Generator Module (or DIGEN)** –There is one available slot for the DIGEN Module. Note that a 4 channel unit will not have the DIGEN slot. SMRT410 with the DIGEN option, the VIGEN Modules are numbered 1 to 4 from bottom to top, with the topmost VIGEN numbered 4. The DIGEN current channels are numbered 5 and 6. When the voltage generators are converted to current generators, they will change on the STVI display as V1 = I7, V2 = I8, V3 = I9, and V4 = I10. For more details on the VIGEN output capabilities see section 1.4.
5. **USB Interface** – the USB 2.0 Interface requires a Type B “downstream” connector, and is primarily used as a communication and control port when used with a PC and Megger AVTS software for automated relay testing. A USB cable is not provided with the test set or in the optional accessories. For computer control, an Ethernet cable is provided. However, should the user desire to use the USB port any standard USB A/B cable will work with the unit. May be used when isolation is required for a secure substation access between the SMRT and the IEC 61850 substation network.
6. **PC/OUT Ethernet Port** is a 10/100BaseTX port, and is the primary PC connection port. This port supports MDI/MDI-X auto cross over configuration, which means both standard and “crossover” Ethernet cables may be used. This port provides the optimal method for downloading EMTP files, DFR streaming, and updating the unit’s firmware as required. The SMRT comes standard with a crossover cable. This port may also be used for connecting to the IEC 61850 substation bus for use in testing IEC 61850 devices. For multiple unit operation, the unit providing the OUT link is providing the master phase reference to all units “downstream”.
7. **IN - 61850 Ethernet Port** is a 10/100BaseTX port, and is primarily used to interconnect multiple SMRT units together for synchronous multi-unit operation. It may also be used to provide access to the substation IEC 61850 network. Note that the IN and STVI ports share a common physical port and cannot be used at the same time. With the PC connected to the PC Port, the SMRT and the PC share the same Ethernet network connection, and thus will not have a secure isolation from each other.
8. **STVI Ethernet Port** – this Ethernet port is a 10/100BaseTX PoE (Power over Ethernet) port, and is the STVI connection port. Used for manual operation, and display outputs when under computer control.



1.1.2 Front Panel:

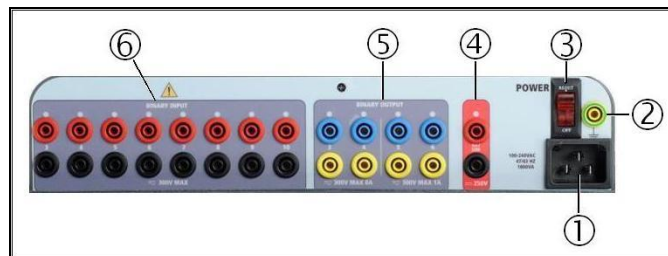

Figure 123 SMRT410 with P Option Front Panel

1. **Incoming Power / Line Cord** – the input line cord, ground terminal, are mounted on the front panel of the test set for both the N and P option units.

Input Line Cord



The test set is equipped with a line cord, which connects to the male connector on the front panel. Verify the input voltage before connecting the line cord to the power source.

2. **Earth Ground Jack** – use this terminal to connect chassis ground to earth ground.



A chassis ground (earth) point on the front panel is provided as an additional safety ground.

3. **POWER ON/OFF Switch** – used to switch unit on and off. The switch illuminates when power is on.
4. **Battery Simulator** – the SMRT410 with the P option provides a variable dc output voltage from 5 to 250 Volts, at 100 Watts (4 Amps Max) providing logic voltage for solid-state relays. When powered ON, the LED above the output terminals illuminates. The SMRT410 with the N option does not include a battery simulator.
5. **Binary Outputs** – the P option provides 4 additional Binary Outputs, numbered 3, 4, 5 and 6. Each Binary Output can be configured as Normally Open or Normally Closed contacts providing logic to the device under test. Binary Outputs 3 and 4 have an AC Rating of 400 V max., I_{max}: 8 amps, 2000 VA max. breaking capacity, and a DC Rating of 300 V max., I_{max}: 8 amps, 80 Watts, with a Response Time: < 10ms. Binary Outputs 5 and 6 are high speed and have an AC / DC Voltage Rating of 400 V peak, I_{max}: 1 amp, with a Response Time: < 1ms typical. The programmable wait duration is from 1 millisecond to 10,000 milliseconds. An LED directly above the terminals indicates the status of the contact. ON indicates closed, and OFF indicates open. The SMRT410 with the N option does not include the additional Binary Outputs 3 through 6.
6. **Binary Inputs** – the P option provides 8 additional (numbered 3 through 10), independent, galvanically isolated, Start/Stop or Monitor circuits to monitor operation of relay contacts or trip SCR. A continuity light is provided for each input gate. Upon sensing continuity, or voltage applied, the lamp will glow. In addition to serving as wet/dry contacts the Binary Inputs may be programmed to trigger binary output sequence(s). Binary Inputs can also be programmed using Boolean logic for more complex power system simulations. The Binary Inputs will accept a voltage range of 5 to 300 VAC or 5 to 250 VDC, or dry Normally Open / Normally Closed contacts. The SMRT410 with the N option does not include the additional Binary Inputs 3 through 10.

1.2 Input Power

The input voltage rating varies depending upon the model number. If the model number has a letter **F** or **G** in the 5th digit, the input voltage may be from 100 to 240 VAC, $\pm 10\%$, 50/60 Hertz. If the letter is either **C** or **E**, the input voltage may be from 220 to 240 VAC, $\pm 10\%$, 50/60 Hertz. Total maximum output power will be limited for CE marked units⁹. Input current required varies with the number of output modules in use, load, and input voltage value. The maximum input current is 15 Amps. The input is protected by an ON/OFF switch / circuit breaker.

⁹ For CE mark units only (C or E in the 5th digit), a derating of the simultaneously available total output power of the current / voltage amplifiers and battery simulator will occur. The maximum output power of a single amplifier is not affected.

1.2.1. Input Power Cord

Depending on the country, the power cord can come with a NEMA 5-15 male connector, a CEE 7/7 Schuko two prong connector, with International Color Coded pig-tail wires (light blue, brown and green with yellow stripe) with the insulation jacket stripped ready for installation of the appropriate male connector, or with UK power cord.

Model SMRT410 **XXXXXXA** comes with a North American power cord (part number 620000).

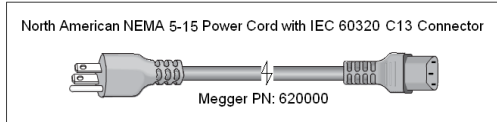

Model SMRT410 **XXXXXXE** comes with a Continental Europe power cord (part number 50425).

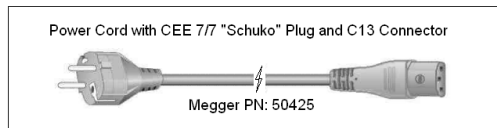

Model SMRT410 **XXXXXXI** comes with an International Color Code power cord. The cord, part number 15065, is ready for wiring to the appropriate plug (depending on country). The following colors apply, Brown = Line, Blue = Neutral and Green/Yellow = Ground.

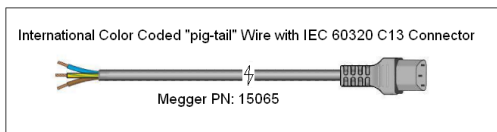

Model SMRT410 **XXXXXXU** comes with a UK power cord (part number 90002-989).

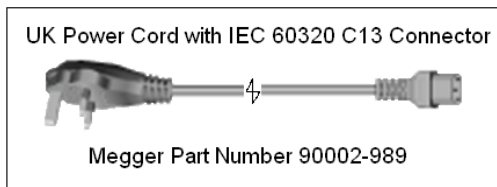

1.3 Voltage - Current Generator (VIGEN) and Double-Current (DIGEN) Modules

Voltages and Currents are noted by the red and yellow surrounding each output channel. Phases 1, 2, 3 and 4 voltage channels are denoted by the red color. Phases 1, 2, 3 and 4 current channels are denoted by the yellow color. The optional Double Current module includes two current channels phases 5 and 6, and are also surrounded by yellow. All outputs are independent from sudden changes in mains voltage and frequency, and are regulated so changes in load impedance do not affect the output. All amplifier outputs are isolated or floating. The SMRT units can be ordered with the amplifier common returns tied to chassis ground as an option.

1.3.1. Convertible Voltage/Current Amplifier



The SMRT PowerV™ voltage amplifier provides a flat power curve from 30 to 150 Volts in the 150V range to permit testing of high current applications such as panel testing. The following outputs are provided.

Voltage Range	Power / Current (Max)
30.00V	150VA @ 5.0A
150.00V	150VA Constant Output Power from 30 to 150 Volts
300.00V	150VA @ 0.5A

Voltage Amplifier in Current Mode:

The voltage amplifier is convertible to a current source with the following output capability. Output power ratings are specified in rms values and peak power ratings.

Output Current	Power	Max V	Duty Cycle
5 Amperes	150 VA (212 peak)	30.0 Vrms	Continuous
15 Amperes	120 VA	8.0 Vrms	90 Cycles

With a 4 channel SMRT unit, convertible channels in conjunction with the four main current channels, provides 8 currents. When the voltage generators are converted to current generators, they will change on the STVI display as current phases 5, 6, 7, and 8. If the optional Double-Current (DIGEN) module is installed, the convertible channels will be labeled current phases 7, 8, 9, and 10.

 The voltage amplifier output is protected from short circuits and thermally protected against prolonged overloads. In case of a short circuit or a thermal overload, the amplifier will automatically turn off, and if the STVI is connected a message to the user will be displayed indicating which condition exists. If AVTS software is used, a similar message will appear.

1.3.2. Current Amplifier



The SMRT current amplifier delivers maximum compliance voltage to the load constantly during the test, and range changing is done automatically, on-the-fly, under load. This insures better test results, saves time by not having to turn the outputs off to change output taps or ranges, and unlike single range current amplifiers insures a higher compliance voltage at lower test currents. Constant power output in many cases eliminates the need to parallel or series current channels together to test high burden relays. The following are typical output current and associated available compliance voltage values. The per channel output current and power ratings are specified in AC rms values and peak power ratings. Specified duty cycles are based upon typical room ambient.

Output Current	Power	Max V / Duty Cycle
1 Ampere	15 VA	15.0 Vrms Continuous
4 Amperes	200 VA (282 peak)	50.0 Vrms Continuous
15 Amperes	200 VA (282 peak)	13.4 Vrms Continuous
30 Amperes	200 VA (282 peak)	6.67 Vrms Continuous
60 Amperes	300 VA (424 peak)	5.00 Vrms 90 Cycles

DC 200 Watts

 The current amplifier output is protected from open circuits and thermally protected against prolonged overloads. In case of an open circuit or a thermal overload, the amplifier will automatically turn off, and if the STVI is connected a message to the user will be displayed indicating which condition exists. If AVTS software is used, a similar message will appear.

1.4 Binary Inputs and Outputs

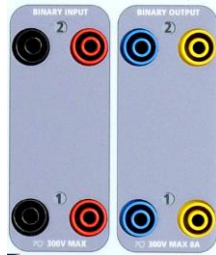

Figure 124 Binary Inputs and Outputs 1 and 2

Binary Inputs and Outputs are clearly marked and logically grouped. The unit's Top Panel will appear different among units, which means Binary Input / Output 1 will always be occupied while Binary Input / Output 2 may, nor may not, depending on the configuration. The 'N' version consists of a system board with only the power and communication ports. The 'P' version adds 8 additional binary inputs, 4 additional binary outputs and a battery simulator. The Binary Inputs are used to monitor relay trip contacts for performing pickup and dropout tests as well as for performing timing functions. The Binary Outputs are used to simulate normally open / normally closed contacts for testing breaker failure schemes, or similar power system operations. In addition they may also be used to switches AC/DC voltages and currents.



Figure 125 "P" Option
Binary Inputs 3 to 10 and
Binary Outputs 3 to 6

1.4.1 Binary Inputs

The binary inputs are specifically designed to measure high speed operation of electro-mechanical, solid-state and microprocessor-based protection relays. All binary Inputs default to Monitor Mode, Contact change of state, latched OFF.

If using the STVI or STVI software to change a binary input from Contact change of state to Voltage Applied / Removed click on or touch the Input Type window and a sine wave will appear where the Contact icon was indicating. The input is now set for voltage sensing.

To change the binary input from Monitor mode to Timer Mode, click on or touch the Use as Monitor button and the display window will change to show Use as Trip, Latched, meaning the binary input is now set to stop the timer upon sensing the first contact closure (if the Input Type is set for contact) or upon sensing voltage if the Input Type is set to Voltage Sensing.

1.4.1.1 Start, Stop, and Monitor Gates

In the SMRT410 there are up to ten identical, independent, programmable gate circuits that permit simple selection of the desired mode for timing or contact monitoring operation.

To monitor operation of the contacts or trip SCR in the device under test, a light is provided for each gate. The gate circuit is isolated for voltage-sensing and can monitor solid-state logic signals. Each light will illuminate once contacts close or voltage is applied to the gate.

1.4.1.1.1 Dry Contacts Open

Timer stops or a continuity indicator goes out at the opening of normally closed contacts, or when conduction through a semiconductor device, such as a triac or a transistor, is interrupted.

1.4.1.1.2 Dry Contacts Close

Timer stops or a continuity indicator glows at the closing of the normally open contacts, or upon conduction through a semiconductor device such as a triac or a transistor.

1.4.1.1.3 Application or Removal of AC or DC voltage

This will either start the Timer or stop the Timer. The continuity indicator will glow (application) or darkens (removal) upon the application or removal of either an AC or DC voltage. To serve a wide range of test applications the binary inputs have different voltage thresholds. For typical test applications binary inputs 1 and 2 have a fixed threshold of 5 volts. On the “P” model there are an additional 8 binary inputs. To monitor TTL signals binary inputs 3 through 6 have a fixed threshold of 3 volts. Binary inputs 7 and 8 have fixed thresholds of 5 volts, and binary inputs 9 and 10 have fixed threshold of 30 volts (for “noisy” test environments). A higher threshold voltage helps to eliminate false triggers due to a noisy source. Lower thresholds allow starting and stopping of timer from TTL voltage signals. The allowable voltage applied is 5 to 300 Volts AC or 5 to 300 Volts DC, current limiting resistors provide protection.

1.4.1.1.4 The Timer can be started when turning on any selected generators.

1.4.1.1.5 The Timer can be started simultaneously with a change in Frequency, Phase Angle, or Amplitude. Also, it can be started simultaneously with a Voltage or Current waveform step.

1.4.2 Binary Outputs

Binary Outputs 1 and 2 are located on the top panel, rated for 300 V at 8 Amps. The SMRT410 “P” system board option provides four additional Binary Outputs numbered 3, 4, 5 and 6. Each Binary Output can be configured as normally open or normally closed contacts providing logic to the device under test. Binary Outputs 3 and 4 have a rating of 300 V AC/DC, 8 amperes and a maximum of 2000 VA breaking capacity (80 watts DC), with a response time of less than 10ms. Binary Outputs 5 and 6 are high speed and have an AC/DC voltage rating of 400 volts peak, 1 ampere and a response time typically less than 1ms.

The contacts may be programmed to open or close, thus simulating circuit breaker operation. The programmable wait duration is from 1 millisecond to 10,000 milliseconds. A fused test lead (fused at 500 mA) is available as an optional accessory to help protect from blowing the internal fuse of binary outputs 5 & 6. The test lead is blue in color so that the user knows it applies to the blue binary outputs. The barrel holder of the test lead is CE marked with a 1000 V, CAT III rating, and marked FUSED 500 mA / 1000 V/ 50 KA.

1.5 Battery Simulator



The SMRT410 “P” model includes the battery simulator, and provides a variable DC output from 5 to 250 VDC rated at 100 Watts, 4 Amperes max. User may select from normal setting values of 24, 48, 125, or 250 VDC, or enter the desired output voltage in the window provided, see the STVI Configuration Screen. The primary application is to provide DC logic voltage to solid-state and microprocessor relays.

Figure 126 Battery Simulator (BAT SIM)



CAUTION:

NOTE: DC voltage is ON and available when the output is turned on using the LCD touch panel or via software command. Do not plug or insert any test lead into the BATTERY SIMULATOR binding posts without first connecting the test leads to the load!

2.0 SETUP

2.1 Unpack System

Unpack the unit and check for evidence of any shipping damage. If there is any visual damage, immediately notify the freight carrier to make a damage claim, and notify Megger of the damage.



CAUTION:

Potentially lethal voltages may be present on the output terminals. It is highly recommended the operator read the user manual thoroughly and have an understanding of the test set operation prior to turning power on.

2.1.1 Initial Start Up

3. With the Ethernet cable supplied with the unit connect the **STVI** Ethernet Port on the SMRT unit to the Ethernet port on the top of the Smart Touch View Interface (STVI). If using the STVI PC version software, connect the **PC/OUT** Ethernet Port on the SMRT unit to the PC Ethernet port.
4. Before connecting power to the unit, make sure the POWER ON/OFF Switch is in the OFF position (0). Plug the unit line cord into an appropriate power source and turn the POWER ON/OFF Switch to ON (I). As the SMRT unit goes through its power up sequence, in about a minute the STVI power up screen will appear, then the manual start up screen will appear.

2.2 Communication Ports

There are several communication ports. These ports are: one USB, three Ethernet, and an optional Bluetooth wireless port.

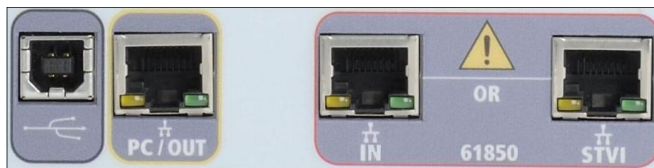

2.2.1 USB 2.0 Interface

USB 2.0 Interface requires a Type B “downstream” connector, and is primarily used as a communication and control port when used with a PC and Megger AVTS or STVI PC version software for automated relay testing.

2.2.2 PC/OUT Ethernet Port

PC/OUT Ethernet Port is a 10/100BaseTX port, and is the primary PC connection port automated relay testing. This port supports MDI/MDI-X auto cross over configuration, which means both standard and “crossover” Ethernet cables may be used. The SMRT comes standard with a crossover cable.

In addition, this port maybe used to download large blocks of data into the unit. It is used to download digital samples for DFR playback, and download software / firmware updates. Since each output channel is capable of storing up to 256,000 samples of Digital Data, such as in Digital Fault Recordings for DFR playback, and with up to six channels that equals over 1.5 million samples. The Ethernet port on the SMRT410 should download the data in 1 second or less. In addition to high speed downloads of DFR data, the port is also used to talk to the SMRT410 unit via a Network.

This port may also be used to interconnect multiple SMRT units together for synchronous multi-phase operation.

2.2.2.1 Setting SMRT IP Address for Operation with a PC

With the Ethernet cable supplied with the unit, connect the **PC/OUT** Ethernet Port on the SMRT unit to the PC Ethernet port. Turn the test set on. As the SMRT unit goes through its power up sequence, in less than a minute the STVI power up screen will appear. If using the PC version of the STVI software it will auto-detect the SMRT unit connected to the PC. Once it auto-detects the unit, and determines the configuration of the SMRT unit connected, the Manual screen will appear. The unit might not auto detect due to firewall settings. In this case the firewall can be turned off or you can enter the IP address directly using the PowerDB instrument configuration

screen by clicking on the Instrument Setup icon on the PowerDB tool bar . From the Instrument Configuration Screen, shown in the following figure, click off the check mark in the Auto Discover Unit box.

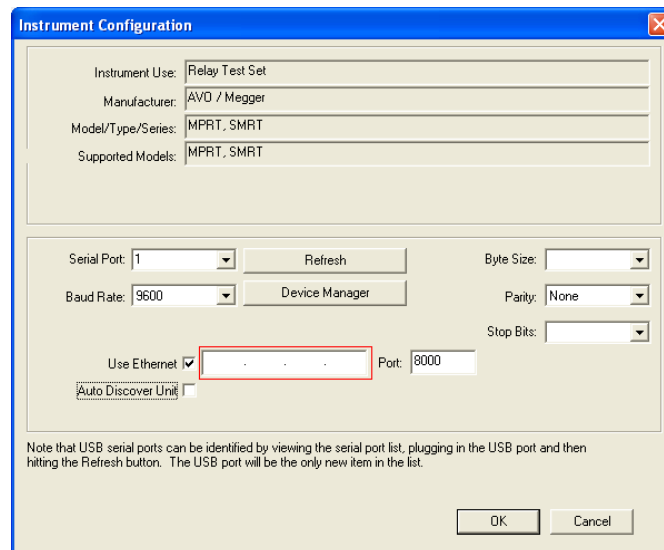

Figure 127 PowerDB Instrument Setup Screen

Here the user can enter the IP address directly into the box highlighted in red. The IP address of the unit can be determined by counting the number of times the Binary Output led flashes at the end of boot up cycle (the address is 169.254. <#flashes>.0). If the unit flashed four times, the

address would be 169.254.4.0 . If the unit is on a network with a DHCP server, the user must use the Auto Discovery mode.

2.2.3 STVI Ethernet Port

STVI Ethernet Port is a 10/100BaseTX PoE (Power over Ethernet) port, which is the STVI connection port. This port provides power to the STVI using POE (Power Over Ethernet), and manual control of the SMRT unit with the STVI.

2.2.3.1 Setting SMRT IP Address for Operation with STVI

With the Ethernet cable supplied with the unit, connect the **STVI** Ethernet Port on the SMRT top panel to the Ethernet port on the top of the Smart Touch View Interface (STVI). As the SMRT unit goes through its power up sequence, in less than a minute the STVI power up screen will appear. The STVI will auto-detect the SMRT410 (does not require the user to input an IP address). Once it auto-detects the unit, and determines the configuration of the SMRT unit connected, the Manual screen will appear.

2.2.4 IN - IEC61850 Ethernet Port

IN Ethernet Port is a 10/100BaseTX port, and is used when interconnecting multiple SMRT units together. It is also provides access to the substation IEC 61850 network (when enabled). The SMRT410 with the IEC 61850 option enabled provides selectable priority, VLAN-ID, and meets the IEC 61850-5 standard Type 1A, Class P 2/3, for high speed trip and reclose simulations.

2.2.4.1 Setting SMRT IP Address for Networks or IEC 61850 Operations



The SMRT410 maybe controlled over a network. This provides remote control of the SMRT410 virtually over any distance allowing one PC to control at least two units simultaneously, such as in end to end testing.



Connecting the SMRT410 to a Local Area Network or a Wide Area Network could permit unauthorized operation of the unit.

Through the IN Ethernet port, the SMRT410 integrates into a network just like a PC or server. To use this feature requires the user to setup the IP configuration of the SMRT410 for their LAN. Note that the SMRT410 when turned on will automatically search for and acquire a network address if connected to a network. If it fails to automatically acquire an address check to make sure you are properly connected using a standard Ethernet cable. **Do not** use the cross over Ethernet cable supplied with the test set (a cross over cable is designed for use from your PC to the test set, not to a network). If the unit still fails to acquire an address then there may be other issues. This will probably require assistance from your company's information management department.

For IEC 61850 testing connect the IEC61850 IN port to the substation bus or to the relay under test to receive and send GOOSE messages. When used with the Megger GOOSE Configurator in the AVTS software, the SMRT410 can provide high speed testing of IEC 61850 relays and substations by subscribing to GOOSE messages and mapping to the binary inputs. In addition, it can simulate system conditions such as circuit breaker operation by publishing GOOSE messages mapped to the SMRT410 binary outputs. With the PC connected to the OUT port, and running AVTS Megger GOOSE Configurator software, the operator can "sniff" the substation network. However, if a secure port is desired, where the operator cannot accidentally trip off the substation or inflect a PC virus into the substation LAN, connect the PC to the SMRT USB port and sniff the network through the IEC61850 IN port.

3.0 Current Sources

3.1 Parallel Operation

Each SMRT current amplifier is capable of providing 30 Amperes continuous, and up to 60 amperes for 1.5 seconds for testing instantaneous trip elements. When more than 30 amps single phase is required for long durations, or 60 Amps for testing instantaneous elements, three or more current channels may be connected in parallel to provide 90 up to 180 Amperes continuous, and from 180 up to 360 amperes for short durations.

! Note: If an **F** appears in the 5th digit of the style identification number (i.e. 40P1**F**0A0S1) the current returns are floating (isolated from each other and ground). Those units with a style number **G**, the current returns are common together internally and connected to earth ground.

To parallel the current channels of the unit, perform the following:

If using the sleeved multi-lead current test leads (part number 2001-396), all of the black return leads are interconnected together inside the sleeve so they will all share the return current together. Connect each current channel to the relay under test (both red and black terminals to the load). Each Megger test lead is rated for 32 Amperes continuous. If using test leads other than those supplied by Megger insure that the wire has sufficient size to carry the test current.

! For the earth grounded common return (G) units, there is an internal common ground between the current channel return terminals. If using separate individual test leads, all of the return leads will need to be common together at the load as shown in the following figure. By not connecting a return lead to all of the current channels in use, part or all of the return current will be forced through the internal ground. That means with 4 channels in parallel up to 240 Amperes could be forced through the internal common ground, and will cause damage to the internal common returns. Therefore, it is important that the parallel connections must be made at the relay. See the following figure.

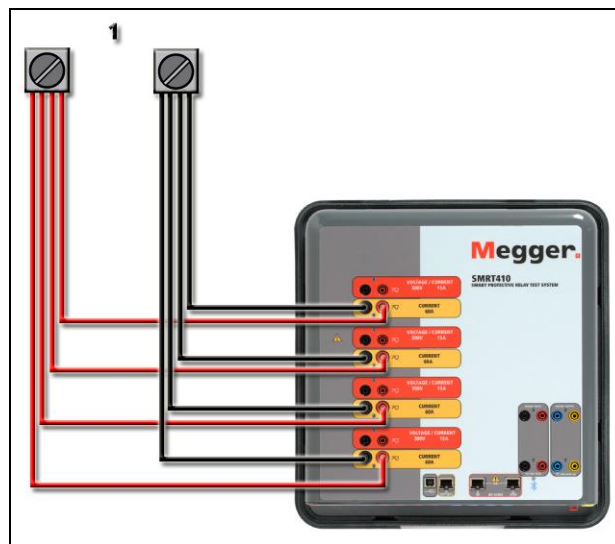

Figure 128 Parallel of Four Current Outputs

3.1.1 Manual Test Screen - Single Phase Up To 240 Ampere

For ease of use and operator convenience, go to the Configuration screen and select the Operating Mode of **4 Voltages – 1 Current @ 240 amps**. When you return to the manual test screen there will be one current channel displayed, as shown in the following figure.

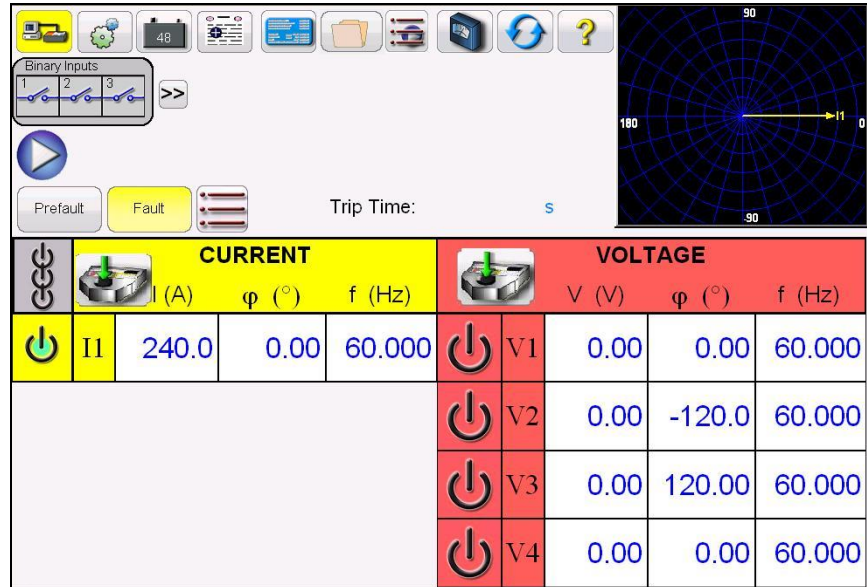

Figure 129 Manual Test Screen – 4 Channel SMRT410 Single Phase Operation

The STVI will automatically set all four currents in phase with each other and divide the current equally between the four current amplifiers. When setting an output, simply enter the value of the desired output current. For example, for an output of 100 Amperes, enter 100, while each current amplifier will be providing 25 Amperes. The current can also be phase shifted. Simply enter the desired phase angle and all four currents will be phase shifted together.

If two current channels that are to be used in parallel, leave the unit in the default four phase configuration. Connect the two current outputs to the load as shown in the following figure.

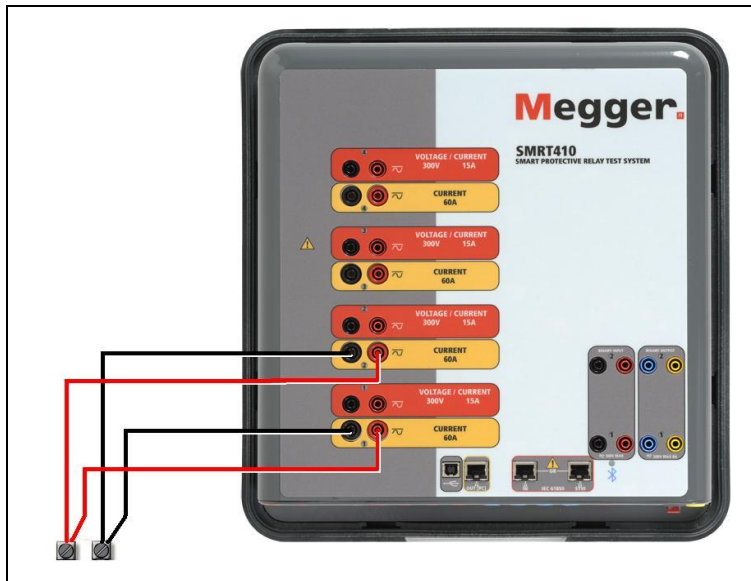



Figure 130 Two Currents in Parallel

Set each channel to one-half of the output requirement. Be sure and reset current channel #2 to 0 degrees so that it will be in-phase with current channel #1. With both current channels selected, turn output on by pressing or clicking on the ALL ON/OFF button. Always use the ALL ON/OFF button to turn both current channels on and off together. For manually ramping outputs, if using the PC version of the STVI software the $\uparrow\downarrow$ buttons will be displayed. If using an STVI controller the Control Knob icon  will be displayed. Pressing either of these two will present the user with a window to select the desired level of increment for manually ramping the outputs, the desired channel(s) to be ramped, and what is to be adjusted (amplitude, phase angle or frequency).

3.2 Currents in Series Operation

Two current channels may be connected in series in order to double the available compliance voltage. High impedance electromechanical ground (earth) overcurrent relays have always been difficult to test at high multiples of tap due to the winding impedance and saturation characteristics. The peak voltage required can exceed the maximum output voltage of one SMRT410 current output channel, depending on the required test current. By connecting two current outputs in series, the compliance voltage is doubled, providing higher test currents through the load. There are two methods to series currents together. For the floating output (F) models connect the two current amplifiers in a “push-push” configuration as shown in the following figure.

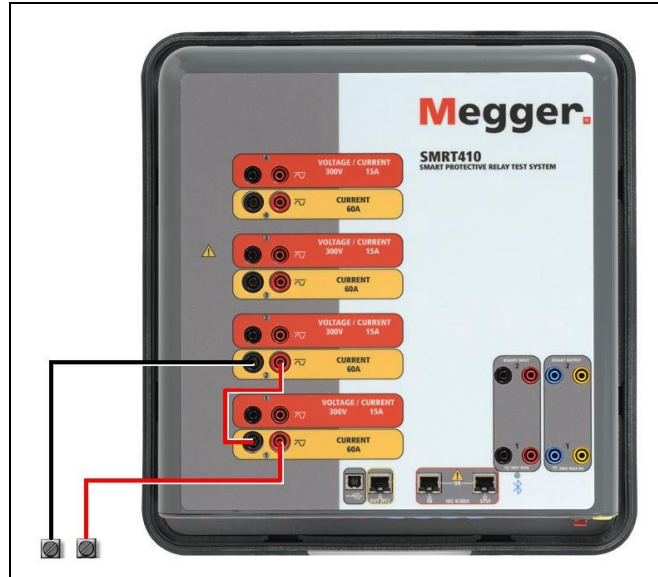



Figure 131 Series Two Currents with Floating Output Unit

The two current channels that are to be used in series set each to the same test current magnitude, and phase angle. Select both current channels and turn output on by pressing or clicking on the ALL ON/OFF button. Always use the ALL ON/OFF button to turn both current channels on and off together. For manually ramping outputs, if using the PC version of the STVI software the $\uparrow\downarrow$ buttons will be displayed. If using a STVI controller the Control Knob icon  will be displayed. Pressing either of these two will present the user with a window to select the desired level of increment for manually ramping the outputs, the desired channel(s) to be ramped, and what is to be adjusted (amplitude, phase angle or frequency).

To series the current channels of the common grounded returns (G) unit, perform the following:

Using the current channel test leads, connect the Red output terminals of the two current channels to the relay under test. Even though the two returns associated with the current channels are connected internally with the common returns, place a jumper as shown. This will insure that the internal common leads will not be damaged.

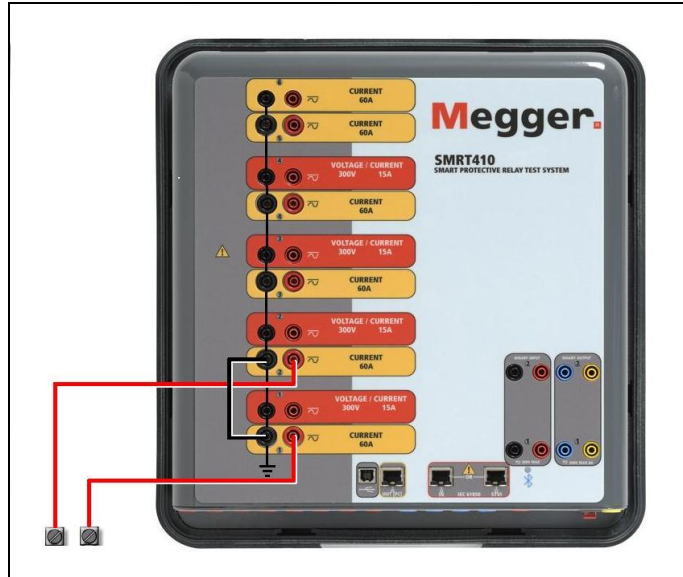



Figure 132 Series of Two Current Channels with Grounded Common Returns

! NOTE: One current channel should be set to 0 degrees and the other current channel should be set to a phase angle of 180 degrees so that the two compliance voltages add across the load. DO NOT attempt to series more than two currents together on a grounded common returns unit.

The two current channels that are to be used in series set each to the same test current magnitude. Initiate the two current channels simultaneously by pressing the ALL ON/OFF button. Always use the ALL ON/OFF button to turn both current channels on and off together. For manually ramping outputs, if using the PC version of the STVI software the $\uparrow\downarrow$ buttons will be displayed. If using an STVI controller the Control Knob icon  will be displayed. Pressing either of these two will present the user with a window to select the desired level of increment for manually ramping the outputs, the desired channel(s) to be ramped, and what is to be adjusted (amplitude, phase angle or frequency).

4.0 Voltage Sources

4.1 Outputs Summed Together

Two voltage channels may be used to sum the voltage outputs to obtain higher than rated voltage provided the load is ungrounded. Connect the load between the voltage channel posts, set V_1 Phase to 0° and set V_2 Phase to 180° . The voltage outputs will add so the total voltage is the sum of the two voltage amplitudes, V_1 and V_2 as can be seen in the picture below.

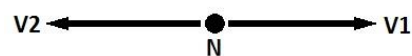

! Note: If an **F** appears in the 5th digit of the style identification number (i.e. 30P1F0A0S1) the voltage returns are floating (isolated from each other and ground). Those units with a style number **G** the voltage returns are common together internally and connected to earth ground.

For the floating common units the user must connect the associated voltage channels black common returns together, when series operation is required (see the following figures). Remove external commons when testing is completed.



DO NOT attempt to series more than two voltage channels together. The test leads are rated for 600 Volts maximum.

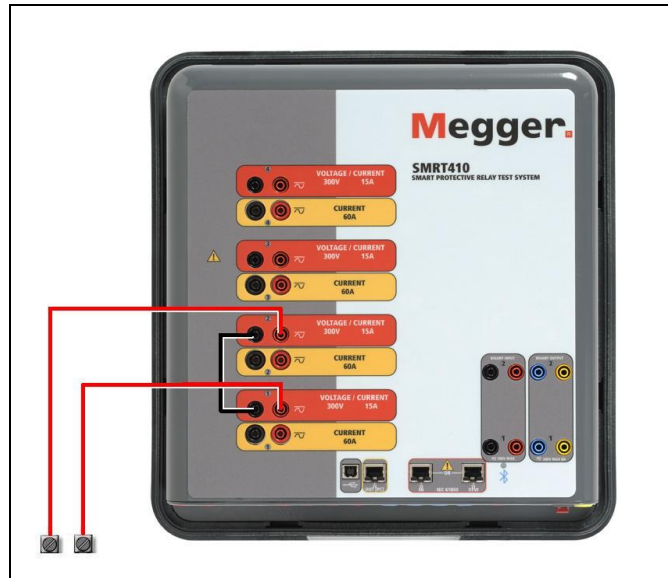

Figure 133 Series of Voltage Channels for Floating Ungrounded Common Returns

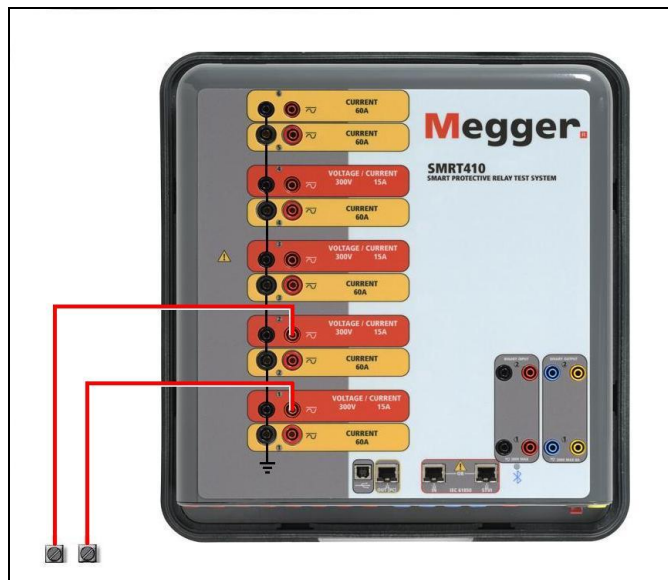

Figure 134 Series of Voltage Channels with Grounded Common Returns

4.2 3Ø, 3-Wire, Open-Delta and T-Connection

4.2.1 Balanced Open Delta

Two methods of obtaining a three-phase, three-wire voltage source are available. The Open-Delta configuration is the easier to use when a balanced three-phase source is required because the amplitude and phase relationship can be set directly. No calculations are necessary.

When using the Open-Delta configuration, it is suggested to use voltage channel #1, designated V_1 , and voltage channel #2, designated V_2 , while the COMMON binding post is designated V_g . With this arrangement, the magnitude and phase angle of the potentials can be easily calculated and set. For the balanced three-phase condition V_{1g} and V_{2g} are equal in magnitude and separated by an angle of 60° . This is done by setting the V_1 and V_2 potentials equal in magnitude, setting 0° on V_1 and 300° (60 degrees leading assuming that the default phase rotation is set to 360 Lag) on V_2 , see the following figures.

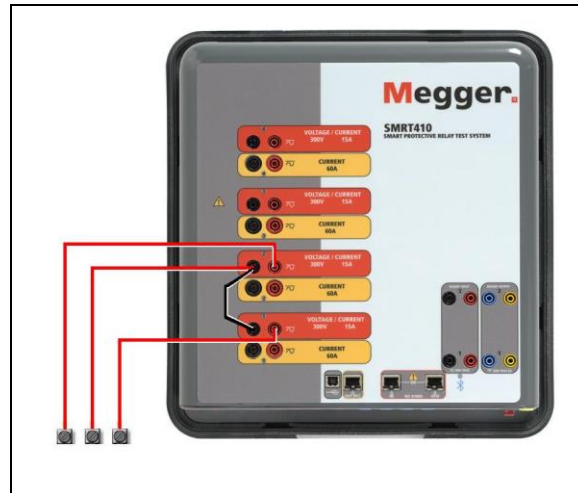
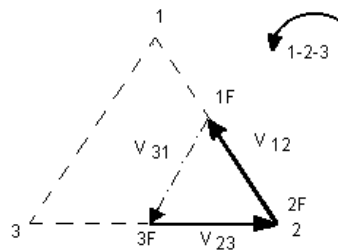

Figure 135 Three Phase Open Delta Connections

When using the Open-Delta Configuration to set up a phase-to-phase fault, calculations' using the Law of Cosines is required to calculate amplitude and phase relationships. (See discussion under T-Connection for simulating unbalanced, phase-to-phase faults without need for calculations.)



Balanced 30° - Open Delta Connection
 If V_f equals the desired test potential, then:
 Set $V_1 = V_f \angle 0^\circ$
 Set $V_2 = V_f \angle 300^\circ$ Lagging (60° Leading)

4.2.1.1 Unbalanced Open Delta

When setting up an Unbalanced Open-Delta configuration, the desired phase-to-phase fault voltage, V_{1f} is set using voltage channel #1 with its phase angle set to 0° . Phase-to-phase voltage V_{2f} and its phase angle relationship for voltage channel #2, must be calculated using the Law of Cosines; where For any triangle the following formula applies:

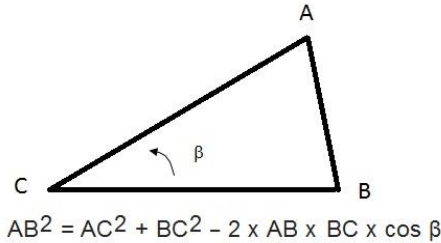

The next figure shows the phase relationships between voltages and an example of the necessary calculation. For convenience the amplitude and the phase angle settings for the typical V_f fault magnitudes are tabulated.

From the Law of Cosines

$$\theta = \arccos\left(\frac{V_{12}}{2 * V_{23}}\right)$$

$$V_{23}^2 = \left(\frac{V_{12}}{2}\right)^2 + \left(\frac{\sqrt{3}}{2} * 120\right)^2$$

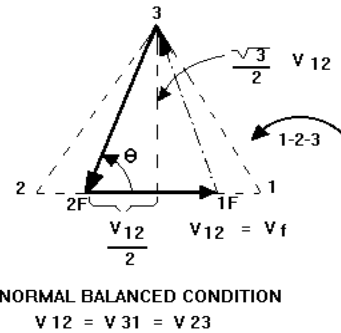

Figure 136 Open-Delta Unbalanced phase-to-phase Fault Voltages

Settings for Typical Phase-to-Phase Fault Voltages

$$V_{12} = V_{\text{fault}}$$

V_{12}	1	5	10	15	20	25	30	35	40	45	50	55	60	65	70
V_{23}	104	104	104	104	104	105	105	105	106	106	106	108	108	109	110
At θ° Lag	270	271	273	274	275	277	278	280	281	282	284	285	286	287	289

4.2.2 T Connection

The second method of obtaining a three-phase, three-wire voltage source is the so-called T-Connection. The method, shown in the following figure, is easier to use when obtaining an unbalanced, phase - to -phase fault simulation since it eliminates calculations. To reduce confusion when using the T-Connection, the voltage output #1 is designated V_a and its phase angle set at 0° , voltage output #2 is designated V_b and its phase angle set for 180° , and voltage output #3 is designated V_c and its phase angle is set for 270° . Any combination of balanced three phase faults or unbalanced phase-to-phase fault conditions can be easily simulated. The following figure indicates these phase relationships.

! NOTE: This method should not be used for very low fault voltages, or used on solid state relays that may be sensitive to this type of connection (i.e. 5 volts or less, or for testing ABB or Westinghouse type SKD relays).

$$V_f = \text{Desired Fault Voltage}$$

$$V_a = \frac{1}{2}V_f \angle 0^\circ$$

$$V_b = \frac{1}{2}V_f \angle 180^\circ$$

$$V_c = \frac{\sqrt{3}}{2} 120 \text{ or } V_c = 104V \angle 270^\circ$$

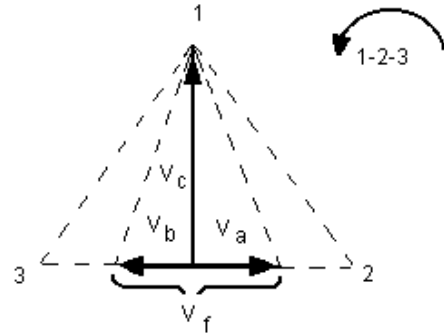

Balanced or Unbalanced Fault T-Connection

4.3 3Ø, 4-Wire, Y-Connection

A three-phase, four-wire potential system can be provided using three output modules. The vector relationships are referenced below. This Y-Connection has the advantage of being able to supply a higher line-to-line voltage ($1.73 \times$ phase-to-neutral voltage). It is ideally suited for simulating phase-to-ground faults. Voltage channel #1 is designated as V_a with its phase relationship set for 0° . Voltage channel #2 is then designated as V_b and phase angle set for 120° . Finally, voltage channel #3 is designated V_c and phase angle set for 240° (for a 1-2-3 counter clockwise rotation). V_a , V_b and V_c are connected to the voltage potential binding posts on the respective test sets.

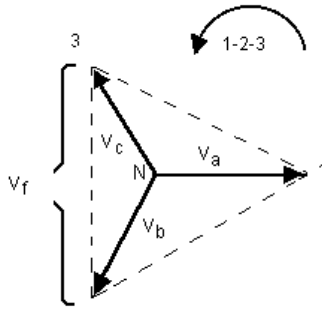

Balanced 3 ϕ , 4 Wire Y-Connection

$$V_f = \text{Desired Fault Voltage}$$

$$V_a = \frac{\sqrt{3}}{3} V_f \angle 0^\circ$$

$$V_b = \frac{\sqrt{3}}{3} V_f \angle 120^\circ$$

$$V_c = \frac{\sqrt{3}}{3} V_f \angle 240^\circ$$

! Note: If an **F** appears in the 5th digit of the style identification number (i.e. 30P1**F**0A0S1) the voltage returns are floating (isolated from each other and ground). Those units with a style number **G** the voltage returns are common together internally and connected to earth ground.

If using the sleeved multi-lead voltage test leads (part number 2001-395), all of the black return leads are interconnected together inside the sleeve so they will all share the return together. Therefore, only one return lead is provided on the relay connection side of the sleeved leads (similar to the connections in the following figure).

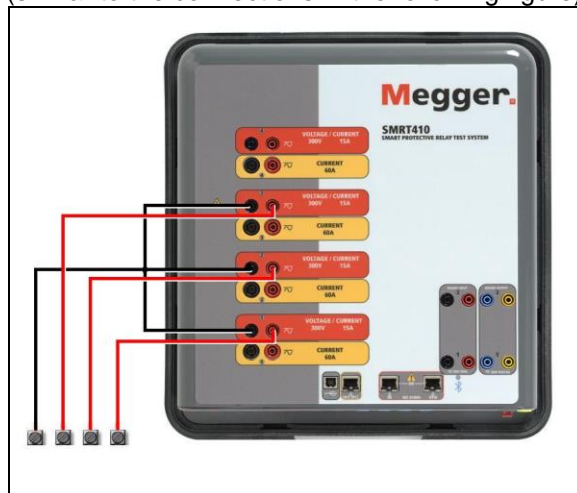

Figure 137 Three Phase Four Wire Test Connections

! For the earth grounded common return (G) units, there is an internal common ground between the voltage and current channel return terminals. Therefore, only one return lead is required for the voltage channels. If using separate individual test leads, for the floating common units the user must connect the associated voltage channels black common returns together as shown above.

5.0 Warranty Statement

Megger warrants the product is free of defects in material and workmanship for a period of one (1) year from date of shipment. This warranty is non-transferable. This warranty is limited and shall not apply to equipment that has damage, or cause of defect, due to accident, negligence, and improper operation, faulty installation by the purchaser, or improper service or repair by any person, company or corporation not authorized by Megger. Megger will, at its' option, either repair or replace those parts and/or materials it deems to be defective.

The warranty is in lieu of all other warranties, either expressed or implied on the part of Megger and in no event shall Megger be liable for the consequential damages due to the breach thereof.

5.1 Preventive Maintenance

The unit utilizes surface mount technology (SMT) and other components which require little or no service except for routine cleaning, etc. The unit should be serviced in a clean atmosphere away from energized electrical circuits.

5.1.1 Examine the unit every six months for:

Dust and Dirt	To clean the unit, disconnect the power cord from the unit. Never use spray liquids or industrial cleaners. Some cleaning solvents can damage electrical components, and should never be used. Water and a mild soap may be used. Use a lightly damp cloth (not dripping wet) to wipe off the unit. A dirty heat sink can cause thermal overloads. Remove dust with dry, low pressure, compressed air. Either remove the module from the chassis or simply apply air forcing the dust away from the heat sink through the sides of the unit.
Moisture	Remove moisture as much as possible by putting the test set in a warm, dry environment.

5.2 Updating SMRT410 Firmware

Download Firmware Upgrade via Megger Website

To download the newest firmware from the Megger website,

1. Go to WWW.Megger.com
2. **Log In.**
3. Go to **Software Downloads**
4. Click on **SMRT**
5. Click in the window provided and enter the SMRT Serial Number. Note: Make sure you enter the serial number correctly, or it may be rejected.
6. Click on the version of firmware displayed, i.e. **Firmware 1.XX**

The firmware will be downloaded onto the user's PC as a zip file. Create a folder and Extract (unzip) the file to the folder.

Firmware Upgrade via STVI USB Port

Download the firmware to your PC from the Megger website as outlined above, see Firmware Upgrade via Megger Website. Unzip the file, **Select All** files, and **Copy** to a USB memory stick. Interconnect the STVI to the SMRT unit via the Ethernet cable, and power up the test system. Then insert the USB stick into the USB port on the top of the STVI. To perform the upgrade, from the STVI **Configuration Screen** press the **Update Firmware** button. The SMRT410 will automatically look to see if the firmware is a newer version of Software /Firmware, and if it is, it will automatically download the firmware into the unit.

5.3 Service and Repair Instructions

To save turn-around time and reduce costs, SMRT410 was designed as a modular unit. In most cases, if any one module should experience a problem it should not cause the test system to be down. Basic troubleshooting information has been provided to guide the technician to the possible source of a problem.

Since SMRT410 uses Surface Mount Technology, most repairs of the individual modules are beyond the scope of the basic troubleshooting guide, and should be referred to the Service Department at Megger or handled through the Megger Representative.

 If the unit is still within the original warranty period, or limited warranty period following factory servicing, **the factory must be contacted before attempting any repairs or the warranty will be void.**

5.3.1 Basic Troubleshooting

The troubleshooting information relies on the technician to have a good understanding of the operation of the unit. If the technician is unfamiliar with the unit, he or she should not attempt to repair. The technician should contact the factory before attempting repairs. Provide the Megger part number for the part or assembly in question and the serial number of the SMRT410 when making inquiries.

 **WARNING** It is necessary to energize the SMRT410 to properly troubleshoot some of the modules. The technician must take all applicable safety precautions for working near energized circuits.

NOTES

Before suspecting a failure in the SMRT410, review the General Description and Operation sections to ensure that the problem is not a result of operating error.

Preliminary testing of the SMRT410 within its specified limits can help determine if a malfunction actually exists, identify the type of malfunction and define the general area of the failure.

Common causes of malfunctions, other than improper operation, are incorrect power input (voltage above or below specified limits), incorrect test signal voltages applied to the Binary Input gates (outside of the specified AC/DC Applied/Removed limits), and contact or circuit resistance too great for the Dry Contact gates to operate properly on the Monitor/Start/Stop gates. Typical malfunctions for the VI-Gen amplifiers are external short

circuits on the voltage output and open circuits on the current output. The battery simulator and VI-Gen voltage and current outputs can be easily checked using a voltmeter and ammeter.

 **NOTE:** There are four different modules that can make up a SMRT410; the System Board (front panel), VIGEN's (VIGEN#1, and #2) and VIGEN's LITE (VIGEN #3, and #4), and the optional DIGEN. Most problems can be easily resolved by replacement of one of these modules, see section **5.3.1.2.1 Replacing a VIGEN** for instructions on how to replace a VIGEN module. Proper ESD procedures should be followed when handling any SMRT410 module. Failure to do so, may damage sensitive parts.

5.3.1.1 Power Input

Input voltage affects the whole unit and may or may not cause permanent damage if voltage is incorrect. These problems can often be corrected by simply using a better source of input power. For units with an **F** or **G** appearing in the 5th digit of the style identification number (i.e. 40P1**F**0A0S1) the rated voltage limit is auto-selectable from 100 to 240 volts, $\pm 10\%$, 47 to 63 Hz. For units with a **C** or **E** appearing in the 5th digit of the style identification number (i.e. 40P1**C**0A0S1) the rated voltage limit is auto-selectable from 220 to 240 volts, $\pm 10\%$, 47 to 63 Hz.

Some symptoms are as follows:

1. Low voltage: Erratic operation, no output, input power circuit breaker operation.
2. High voltage: Circuit breaker operation, power supply failure in Input Power Module.

5.3.1.2 VIGEN Input Power, Communication and Control

Basic troubleshooting of the input power is as follows.

3. No power: Check the ON/OFF circuit breaker. Does the ON/OFF switch light up? If it does not light up, then power is not getting to the unit. Check power source and line cord. If it lights up then the power is getting to the unit. Check the VIGEN power cable connection.



CAUTION: Turn off main power and unplug line cord before attempting to work on any module. Observe proper Electro Static Discharge procedures.

- A. Disconnect the power cord from the unit.
- B. Remove the two Phillip head screws on each side hold on the top cover; the first top screw and the fourth screw, see the following figure.



Figure 138 SMRT410 Top Cover Securing Screws¹⁰

- C. Remove the front center screw on the front panel, and the two screws (one on each side) of the top cover that connects the top cover to the front panel, see the following figure.

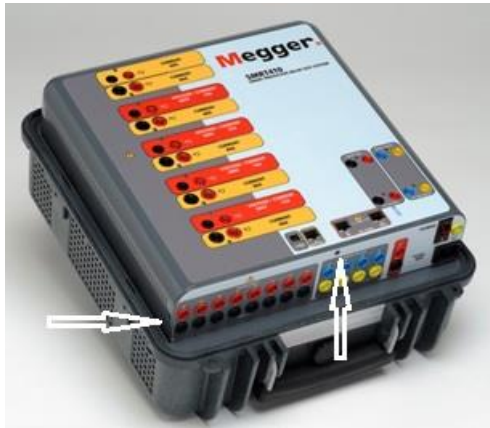

Figure 139 Top Panel Removal Front Panel Screws

- D. To remove the top cover from the enclosure will require an awl, or a small nail punch, and hard flat plastic wedge (like a plastic ruler). Cover the enclosure lip and ridge with the plastic ruler to prevent damage to the enclosure ridge. Place the awl into a vent hole and leverage the cover up slightly on each side, see the following figure.

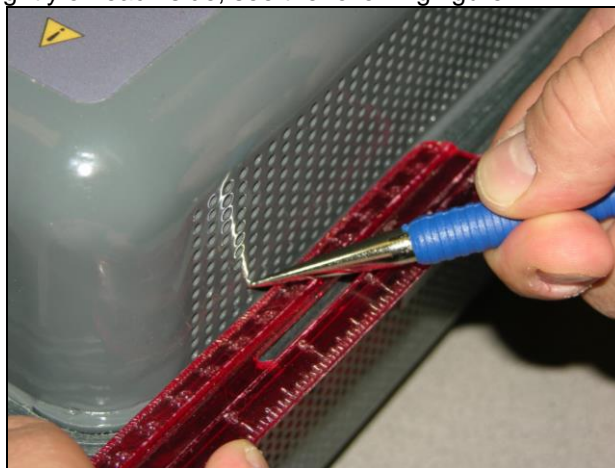

Figure 140 Leveraging the cover from the enclosure

¹⁰ The number of screws that appear of the sides may vary depending on the configuration.

Continue to alternately leverage the cover up until you can work the cover out with your hands by grasping the back of the cover with one hand and gently, yet firmly, pull the cover up from the unit slightly. Then, alternately move the front side up slightly working the cover out of the enclosure. It is tight fit so work slowly and carefully.

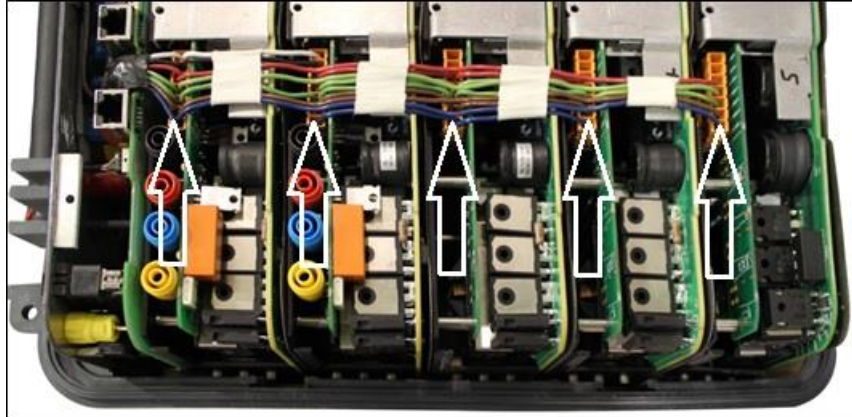

Figure 141 VIGEN Power Connectors for 5 Channel Unit

Check the cables as shown. If the cables are properly connected, then remove and replace the VIGEN per 1.5.3.1.2.1.

4. Erratic Manual Control

Individual Output Module communication cable is not properly connected thus cannot receive proper commands. Look through the air intake holes on the left side of the unit to observe the VI-Gen LED's. Each module has some green LED's that blink. These are associated with the Ethernet communications. If there are no blinking LED's on one or more modules, then the module is not communicating. Remove the top cover using the procedure described above.



CAUTION: Turn off main power and unplug line cord before attempting to reseat any cables. Observe proper ESD procedure.

Locate the communication Ethernet cables on the left side, see the following figure.

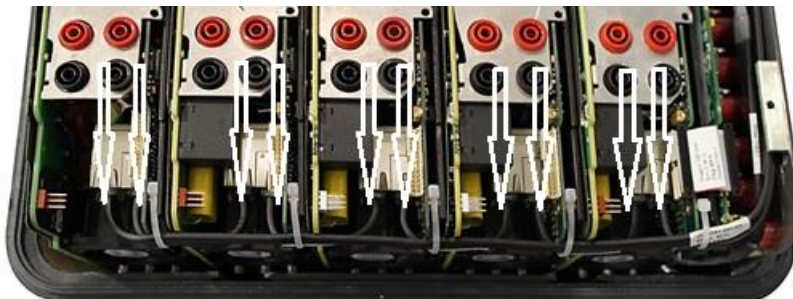

Figure 142 Communication Cable Connections 5 Channel Unit

Carefully disconnect each cable and reconnect to insure the cable locks into position. Note: In order to reseat each communication cable the

small wire-ties will need to be removed (replacement wire-ties will be required after reseating the cables).



CAUTION: Failure to replace wire-ties may pinch the communication cables upon replacement of the top cover.

After reseating the cables, reinstalling the top cover assembly, reconnect the power cord and power up the unit. Look through the air intake holes on the left side of the unit to observe the VI-Gen LED's. If there is still no blinking LED's on one or more modules, and then replace the VI-Gen Module(s) that are not communicating. If they are not lit, then remove the power cord and the top cover and check the power connection cables to each VIGEN as described in Step 1 above.

5.3.1.2.1 Replacing a VIGEN

1. To remove the VIGEN, on early units there are three Phillip head screws that hold in the VIGEN, one on each side and one on the bottom of the unit. Newer generation units only have one screw on the bottom.
2. Remove the power connection cable as shown in Figure 129 above.
3. Disconnect the communication cables as described for Figure 130 above.

-  Note the small cables that connect the front panel board to VIGEN 1 need to be carefully removed prior to removing VIGEN1, see the following figure.



Figure 143 VIGEN1 to Front Panel Cable

4. Carefully remove the VIGEN module from the chassis.
5. Install replacement VIGEN.



Be careful when replacing the module as it is a tight fit, and it is possible to damage components upon extraction or installation.

6. Replace the Phillip head screw(s) that hold in the VIGEN.
7. Reconnect the power connection cable as shown in Figure 129 above.
8. Reconnect the communication cables as shown in Figure 130 above. Replacement wire-ties will be required after reseating the cables.



CAUTION: Failure to replace wire-ties may pinch the communication cables upon replacement of the top cover.

9. If VIGEN #1 was replaced, reconnect the front panel cables as shown in Figure 131 above.
10. Reinstall the top cover. Reconnect the power cord and power up the unit.

5.3.1.3 Binary Inputs, Binary Outputs and Battery Simulator (P Option Unit)

If all the items external of the Timer assembly are in proper order, then the problem exists within the Binary Input / Output assembly itself.

Some basic troubleshooting can pinpoint problems to the approximate cause.

Binary Inputs - Basic troubleshooting is as follows:

1. Timer does not stop:
Jumper the appropriate Binary Input terminals manually. If LED above the selected input lights, check the Binary Input setup screen to verify that the selected binary input is properly setup as a Timer stop post. Check Timer stop settings as N.O. (Normally Open) to close, and Latch On. If LED does not light up, the Binary Input will need to be repaired or replaced.
2. Counting errors:
AC applied or removed Stop signals can create, what appears to be poor repeatability, an inaccuracy or a malfunction in the Timer. The lower the voltage level, the more serious the "error" will be. What appears to be an error, however, is actually a variation in the point on the sine wave at which the voltage is great enough to cause the gate circuit to operate. If the circuit used for the timing test has a low AC voltage and the point at which the contact in the test circuit opens or closes, is at or close to zero on the sine wave, the period of time before the voltage level will be high enough to trigger the gate circuit can be as much as 4 milliseconds. The total timing variation can be as much as 8 milliseconds. The shorter the duration of the timing test, the more significant the variation becomes. Therefore, if small timing variations would present a problem, it is recommended that an AC voltage of 115 volts or above or a DC voltage be used for voltage applied/removed test selections.

When the SMRT410 Timer calibration is being tested, the AC voltage variable is often overlooked. This is particularly true when the Timer is compared to a counter and the two are triggered simultaneously with an electronic switch. For best results, a DC voltage should be used to eliminate the variable. If testing the AC voltage Timer Stop characteristics is desired, then the Stop signal must be triggered at the same point on the sine wave to assure that the gate signal will be repeatable. Ideally, the signal should be at a point near peak in the positive direction. In addition, the specified rms AC voltage values for the various Stop control selections must be adhered to.

Another source of apparent "error" can be the programmable de-bounce feature. If using electro-mechanical contacts for stopping the Timer, and if those contacts have a tendency to bounce, there could be a difference between an external standard timer and the SMRT410 Timer, depending on the programmed de-bounce period set in the SMRT unit. To determine the programmed value, look at the Binary Input Setup Screen and see what the De-bounce setting value is.

If a timing error or variation persists after all the suspected causes of error have been eliminated, then it is possible that the Binary Input circuit is malfunctioning. Contact factory for return instructions.

Binary Outputs - Basic troubleshooting is as follows:

Binary Output LED is ON but output contacts **not closed**:

Using a continuity tester check to see if output circuit is open circuited. If circuit is open then it is possible that the internal surface mounted fuse element has been blown. Note: an optional in-line fused test lead Part Number: 568026 are available to provide protection from switching too high current, see SMRT Ordering Information under Optional Additional Accessories. The unit will need to be returned to the factory for further inspection and repair.

 Contact the factory for a Repair Authorization Number and return instructions if service is required. A Repair Authorization (RA) number will be assigned for proper handling of the unit when it arrives at the factory. Any non-warranty repair cost incurred for the repair or replacement of parts and/or materials shall be the responsibility of the purchaser.

Provide the factory with model number, Unit serial number, serial number of VI-Gen if appropriate, nature of the problem or service, return address, your name, and how to contact you should the factory need to discuss the service request.

You may need to provide a purchase order number, cost limit, billing, and return shipping instructions. If an estimate is requested, provide the name and contact information.

6.0 Preparation for Reshipment

 Save the original shipping container for future use. The shipping container is designed to withstand the rigors of shipping via a common commercial carrier. For example, you may wish to reship your unit to Megger for an annual calibration recertification.

Pack the equipment appropriately to prevent damage during shipment. If a reusable container is utilized, the unit will be returned in the same shipping container if it is in suitable condition.

Add the Return Authorization Number to the address label of the shipping container for proper identification and quicker handling.

 **NOTE:** Ship the equipment without nonessential items such as test leads, etc. These items are not needed by the factory to perform service.

Megger[®]

Addendum D













Model MPRT 8445
Megger Protective Relay Tester

SAFETY PRECAUTIONS

WARNING: VOLTAGES GENERATED BY THIS INSTRUMENT CAN BE HAZARDOUS

This instrument has been designed for operator safety; however, no design can completely protect against incorrect use. Electrical circuits are dangerous and can be lethal when lack of caution and poor safety practices are used. There are several standard safety precautions that should be taken by the operator. Where applicable, IEC safety markings have been placed on the instrument to notify the operator to refer to the user manual for instructions on correct use or safety related topics. Refer to the following table of symbols and definitions.

Symbol	Description
	Direct Current
	Alternating Current
	Both direct and alternating current
	Earth (ground) Terminal. There is a common chassis ground terminal located on the front panel (see Front panel under Description of Controls).
	Protective Conductor Terminal
	Frame or Chassis Terminal
	On (Supply)
	Off (Supply)
	Caution, risk of electric shock
	Caution (refer to accompanying documents)

WARNING: Under no circumstances should the operator or technician attempt to open or service this instrument while connected to a power source. Lethal voltages are present and may cause serious injury or death!

SAFETY PRECAUTIONS (Continued)

The following are some specific safety related items associated with the MPRT test system.

Read and understand all safety precautions and operation instructions before attempting to use this unit.

The purpose of this equipment is limited to use as described in this instruction manual. Should a situation arise that is not covered in the general or specific safety precaution please contact Megger regional representative or Megger, Dallas Texas.

Safety is the responsibility of the user. Misuse of this equipment can be extremely dangerous.

Always start with the power OFF, before connecting the power cord. Make sure outputs are off before attempting to make test connections.

Never connect the test set to energized equipment.

Always use properly insulated test leads. The optional test leads are rated for the continuous output ratings of the test system, and should be properly used and cared for. DO NOT use cracked or broken test leads.

Always turn the test system off before disconnecting the power cord.

DO NOT attempt to use the unit without a safety ground connected.

DO NOT attempt to use the unit if the power cord ground prong is broken or missing.

DO NOT use the test set in an explosive atmosphere.

The instrument must only be used by suitably trained and competent persons.

Observe all safety warnings marked on the equipment.

For safety related or other important topics, like the statement below, will be notated with the adjoined symbol. Read the topic carefully as it may relate either to the safe operation of the test system or the safety of the operator.



Under no circumstances should the operator put their hand or tools inside the test system chassis area with the test system connected to a power source. Lethal voltages are present and may cause serious injury or death!

1.0 Operation

The unit's design is a "modular" concept. All controls and outputs are clearly marked and logically grouped so continual reference to the instruction manual should not be necessary once the test operator is acquainted with the operation of the test system.

1.1 General Description

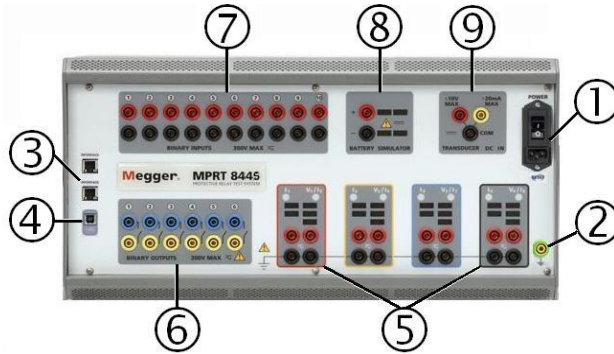

1.1.1 Front Panel

1. Incoming Power / Line Cord –

Input Line Cord

The test set is equipped with a line cord; see the accessory kit, which connects to the male plug on the front panel. Verify the input voltage before connecting the line cord to the power source.



NOTE: The unit can be powered from an input source with a rating of 120 VAC to 240 VAC, 1800 VA max. The unit automatically adjusts to the available power if it is within the specified range.

2. Earth Ground Jack Use this terminal to connect chassis ground to earth ground.



The chassis ground (earth) point on the front panel is provided as an additional safety ground.

- 3. PC IN and STVI Ethernet Ports** are 10/100BaseTX ports. These ports supports MDI/MDI-X auto cross over configuration, which means both standard and "crossover" Ethernet cables may be used. The MPRT8445 comes with a rugged Ethernet cable. The **PC IN** port is the primary PC connection port for automated control of the MPRT8445. It may also be used to provide access to the substation IEC 61850 network for testing IEC 61850 relay schemes. **STVI** Ethernet Port is a 10/100BaseTX PoE (Power over Ethernet) port and is used to connect to the STVI.
- 4. USB 2.0 Interface** requires a Type B "downstream" connector and is primarily used as a communication and control port when used with a PC and Megger AVTS software, or the PowerDB STVI screens. Since the MPRT8445 defaults to a **baud rate of 115,200** the user will need to configure their PC USB output com port to match.

5. **Output Terminals** – The first three phases are noted by the red, yellow, and blue color boxes surrounding each output. Phase A (V1 & I1) is denoted by the red color; Phase B (V2 & I2) is denoted by the yellow color; and Phase C (V3 & I3) is denoted by the blue color. The optional fourth output module is denoted by the black color box. With a fourth output module installed, there may be up to four phases of voltage and current, or two three phase open delta voltages, with four currents, or up to eight phases of current using the convertible voltage channels. The first four phases are indicated by V1/I1, V2/I2, V3/I3 and V4/I4. Once the voltage generators are converted to current generators, they will change as indicated below:

V1 ⇒ I5

V2 ⇒ I6

V3 ⇒ I7

V4 ⇒ I8

6. **Binary Outputs** – There are 6 Binary Outputs. Each Binary Output can be configured as normally open or normally closed contacts providing logic to the device under test. Binary Outputs 1 to 4 have a rating of 300 V AC/DC, 8 amperes and a maximum of 2000 VA breaking capacity (80 watts DC), with a response time of less than 10ms. Binary Outputs 5 and 6 are high speed and have an AC/DC voltage rating of 400 volts peak, 1 ampere and a response time typically less than 1ms.
7. **Binary Inputs** – There are 10 Binary Inputs. Each is independent, galvanically isolated, and serve as Start/Stop or Monitor circuits to monitor the operation of relay contacts or trip SCR. A continuity light is provided for each input gate. All Binary Inputs sense dry Normally Open / Normally Closed contacts or voltage applied or removed with a range of 5 to 300 Volts AC or 5 to 250 Volts DC.
8. **Battery Simulator** – It provides a variable DC output voltage from 5 to 250 Volts at 100 Watts (4 amperes maximum) to provide logic voltage for solid-state relays. When powered ON the LED above the output terminals illuminates.
9. **Measurement (DC IN)** – the DC IN will allow measurements up to ± 10 Volts DC or ± 20 milliamps of current.

1.1.2 Smart Touch View Interface

The Touch View Interface is used in manual operation of the unit. The color LCD touch-panel display and control knob are the operator interface for the unit.



Figure 144 Touch-View Interface

1. **LCD Color Display** – this is an 8.5 inch touch panel display.
2. **Control Knob** – this knob will adjust values once the cursor is in the box location of the value to be changed.

1.2 Input Power

The input voltage may be from 120 to 240 VAC ($\pm 10\%$), 50/60 hertz. Input current required varies with the number of output modules in use, load, and input voltage value. The maximum input current is 15 Amps. The input is protected by an ON/OFF switch / circuit breaker.

1.2.1. Input Power Cord

Depending on the style number, the power cord can come with a NEMA 5-15 male connector, or with the International Color Coded pig-tail wires (light blue, brown and green with yellow stripe) with the insulation jacket stripped ready for installation of the appropriate male connector.

Model MPRT 8445 - **XXXXA** comes with a North American power cord (part number 620000).

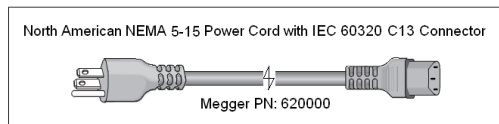

Model MPRT8445- **XXXIX** comes with an International Color Code power cord. The cord, part number 15065, is ready for wiring to the appropriate plug (depending on country). The following colors apply, Brown = Line, Blue = Neutral and Green/Yellow = Ground.

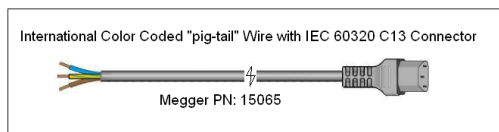

1.3 Voltage - Current Generator (VIGEN) Module

Voltages and Currents are noted by the red and yellow surrounding each output channel. Phases 1, 2, 3 and 4 voltage channels are denoted by the red color. Phases 1, 2, 3 and 4 current channels are denoted by the yellow color. The optional Double Current module includes two current channels phases 5 and 6, and are also surrounded by yellow. All outputs are independent from sudden changes in mains voltage and frequency, and are regulated so changes in load

impedance do not affect the output. All amplifier outputs are isolated or floating. The MPRT units can be ordered with the amplifier common returns tied to chassis ground as an option.

1.3.1. Convertible Voltage/Current Amplifier

The MPRT8445 PowerV™ voltage amplifier provides a flat power curve from 30 to 150 Volts in the 150V range to permit testing of high current applications such as panel testing. The following outputs are provided.

Voltage Range	Power / Current (Max)
30.00V	150VA @ 5.0A
150.00V	150VA Constant Output Power from 30 to 150 Volts
300.00V	150VA @ 0.5A

Voltage Amplifier in Current Mode:

The voltage amplifier is convertible to a current source with the following output capability. Output power ratings are specified in rms values and peak power ratings.

Output Current	Power	Max V	Duty Cycle
5 Amperes	150 VA (212 peak)	30.0 Vrms	Continuous
15 Amperes	120 VA	8.0 Vrms	90 Cycles

With a 4 channel MPRT8445 unit, convertible channels in conjunction with the four main current channels, provides 8 currents. When the voltage generators are converted to current generators, they will change on the STVI display as current phases 5, 6, 7, and 8.

 The voltage amplifier output is protected from short circuits and thermally protected against prolonged overloads. In case of a short circuit or a thermal overload, the amplifier will automatically turn off, and if the STVI is connected a message to the user will be displayed indicating which condition exists. If AVTS software is used, a similar message will appear.

1.3.2. Current Amplifier

The MPRT8445 current amplifier delivers maximum compliance voltage to the load constantly during the test, and range changing is done automatically, on-the-fly, under load. This insures better test results, saves time by not having to turn the outputs off to change output taps or ranges, and unlike single range current amplifiers insures a higher compliance voltage at lower test currents. Constant power output in many cases eliminates the need to parallel or series current channels together to test high burden relays. The following are typical output current and associated available compliance voltage values. The per channel output current and power ratings are specified in AC rms values and peak power ratings. Specified duty cycles are based upon typical room ambient.

Output Current	Power	Max V / Duty Cycle
1 Ampere	15 VA	15.0 Vrms Continuous
4 Amperes	200 VA (282 peak)	50.0 Vrms Continuous
15 Amperes	200 VA (282 peak)	13.4 Vrms Continuous
30 Amperes	200 VA (282 peak)	6.67 Vrms Continuous
45 Amperes	300 VA (424 peak)	6.67 Vrms 90 Cycles
DC 200 Watts		

 The current amplifier output is protected from open circuits and thermally protected against prolonged overloads. In case of an open circuit or a thermal overload, the amplifier will automatically turn off, and if the STVI is connected a message to the user will be displayed indicating which condition exists. If AVTS software is used, a similar message will appear.

1.4 Binary Inputs and Outputs

Binary Inputs and Outputs are clearly marked and logically grouped. The Binary Inputs are used to monitor relay trip contacts for performing pickup and dropout tests as well as for performing timing functions. The Binary Outputs are used to simulate normally open / normally closed contacts for testing breaker failure schemes, or similar power system operations. In addition they may also be used to switches AC/DC voltages and currents.

1.4.1 Binary Inputs

The binary inputs are specifically designed to measure high speed operation of electro-mechanical, solid-state and microprocessor-based protection relays. All binary Inputs default to Monitor Mode, Contact change of state, latched OFF.

If using the STVI or STVI software to change a binary input from Contact change of state to Voltage Applied / Removed click on or touch the Input Type window and a sine wave will appear where the Contact icon was indicating. The input is now set for voltage sensing.

To change the binary input from Monitor mode to Timer Mode, click on or touch the Use as Monitor button and the display window will change to show Use as Trip, Latched, meaning the binary input is now set to stop the timer upon sensing the first contact closure (if the Input Type is set for contact) or upon sensing voltage if the Input Type is set to Voltage Sensing.

1.4.1.1 Start, Stop, and Monitor Gates

In the MPRT8445 there are up to ten identical, independent, programmable gate circuits that permit simple selection of the desired mode for timing or contact monitoring operation.

To monitor operation of the contacts or trip SCR in the device under test, a light is provided for each gate. The gate circuit is isolated for voltage-sensing and can monitor solid-state logic signals. Each light will illuminate once contacts close or voltage is applied to the gate.

1.4.1.1.1 Dry Contacts Open

Timer stops or a continuity indicator goes out at the opening of normally closed contacts, or when conduction through a semiconductor device, such as a triac or a transistor, is interrupted.

1.4.1.1.2 Dry Contacts Close

Timer stops or a continuity indicator glows at the closing of the normally open contacts, or upon conduction through a semiconductor device such as a triac or a transistor.

1.4.1.1.3 Application or Removal of AC or DC voltage

This will either start the Timer or stop the Timer. The continuity indicator will glow (application) or darkens (removal) upon the application or removal of either an AC or DC voltage. To serve a wide range of test applications the binary inputs have different voltage thresholds. For typical test applications binary inputs 1 and 2 have a fixed threshold of 5 volts. On the "P" model there are an additional 8 binary inputs. To monitor TTL signals binary inputs 3 through 6 have a fixed threshold of 3 volts. Binary inputs 7 and 8 have fixed thresholds of 5 volts, and binary inputs 9 and 10 have fixed threshold of 30 volts (for "noisy" test environments). A higher threshold voltage helps to eliminate false triggers due to a noisy source. Lower thresholds allow starting and stopping of timer from TTL voltage signals. The allowable voltage applied is 5 to 300 Volts AC or 5 to 300 Volts DC, current limiting resistors provide protection.

1.4.1.1.4 The Timer can be started when turning on any selected generators.

1.4.1.1.5 The Timer can be started simultaneously with a change in Frequency, Phase Angle, or Amplitude. Also, it can be started simultaneously with a Voltage or Current waveform step.

1.4.2 Binary Outputs

Each Binary Output can be configured as normally open or normally closed contacts providing logic to the device under test. Binary Outputs 1 through 4 have a rating of 300 V AC/DC, 8 amperes and a maximum of 2000 VA breaking capacity (80 watts DC), with a response time of less than 10ms. Binary Outputs 5 and 6 are high speed and have an AC/DC voltage rating of 400 volts peak, 1 ampere and a response time typically less than 1ms.

The contacts may be programmed to open or close, thus simulating circuit breaker operation. The programmable wait duration is from 1 millisecond to 10,000 milliseconds. A fused test lead (fused at 500 mA) is available as an optional accessory to help protect from blowing the internal fuse of binary outputs 5 & 6. The test lead is blue in color so that the user knows it applies to the blue binary outputs. The barrel holder of the test lead is CE marked with a 1000 V, CAT III rating, and marked FUSED 500 mA / 1000 V / 50 KA.

1.5 Battery Simulator

The MPRT8445 battery simulator, provides a variable DC output from 5 to 250 VDC rated at 100 Watts, 4 Amperes max. User may select from normal setting values of 24, 48, 125, or 250 VDC, or enter the desired output voltage in the window provided, see the STVI Configuration Screen. The primary application is to provide DC logic voltage to solid-state and microprocessor relays.



CAUTION:

NOTE: DC voltage is ON and available when the output is turned on using the LCD touch panel or via software command. Do not plug or insert any test lead into the BATTERY SIMULATOR binding posts without first connecting the test leads to the load!

2.0 SETUP

2.1 Unpack System

Unpack the unit and check for evidence of any shipping damage. If there is any visual damage, immediately notify the freight carrier to make a damage claim, and notify Megger of the damage.



CAUTION:

Potentially lethal voltages may be present on the output terminals. It is highly recommended the operator read the user manual thoroughly and have an understanding of the test set operation prior to turning power on.

2.1.1 Initial Start Up

1. With the Ethernet cable supplied with the unit connect the **STVI** Ethernet Port on the MPRT8445 unit to the Ethernet port on the top of the Smart Touch View Interface (STVI). If using the STVI PC version software, connect the **PC IN** Ethernet Port on the MPRT8445 unit to the PC Ethernet port.

2. Before connecting power to the unit, make sure the POWER ON/OFF Switch is in the OFF position (O). Plug the unit line cord into an appropriate power source and turn the POWER ON/OFF Switch to ON (I). As the MPRT8445 unit goes through its power up sequence, in about a minute the STVI power up screen will appear, then the manual start up screen will appear.

2.2 Communication Ports

There are several communication ports. These ports are: one USB, and two Ethernet ports.

2.2.1 USB 2.0 Interface

USB 2.0 Interface requires a Type B “downstream” connector, and is primarily used as a communication and control port when used with a PC and Megger AVTS or STVI PC version software for automated relay testing.

2.2.2 PC IN Ethernet Port

PC IN Ethernet Port is a 10/100BaseTX port, and is the primary PC connection port automated relay testing. This port supports MDI/MDI-X auto cross over configuration, which means both standard and “crossover” Ethernet cables may be used. The MPRT8445 comes with a standard cable. It also provides access to the substation IEC 61850 network (when enabled). The MPRT8445 with the IEC 61850 option enabled provides selectable priority, VLAN-ID, and meets the IEC 61850-5 standard Type 1A, Class P 2/3, for high speed trip and reclose simulations.

In addition, this port maybe used to download large blocks of data into the unit. It is used to download digital samples for DFR playback, and download software / firmware updates. Since each output channel is capable of storing up to 256,000 samples of Digital Data, such as in Digital Fault Recordings for DFR playback, and with up to four channels that equals over 1 million samples. The Ethernet port on the MPRT8445 should download the data in 1 second or less. In addition to high speed downloads of DFR data, the port is also used to talk to the MPRT8445 unit via a Network.

2.2.2.1 Setting MPRT8445 IP Address for Operation with a PC

With the Ethernet cable supplied with the unit, connect the **PC IN** Ethernet Port on the MPRT8445 unit to the PC Ethernet port. Turn the test set on. As the MPRT8445 unit goes through its power up sequence, in less than a minute the STVI power up screen will appear. If using the PC version of the STVI software it will auto-detect the MPRT8445 unit connected to the PC. Once it auto-detects the unit, and determines the configuration of the MPRT8445 unit connected, the Manual screen will appear. The unit might not auto detect due to PC firewall settings. In this case the firewall can be turned off or you can enter the IP address directly using the PowerDB instrument configuration screen by clicking on the Instrument Setup icon on the

PowerDB tool bar . From the Instrument Configuration Screen, shown in the following figure, click off the check mark in the Auto Discover Unit box.

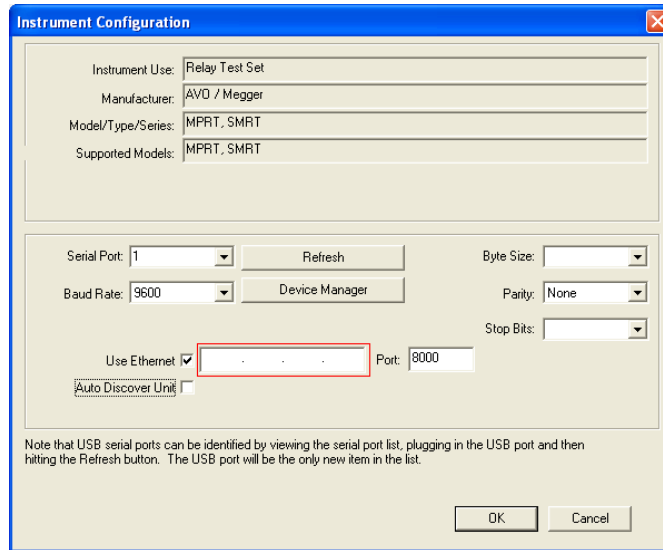

PowerDB Instrument Setup Screen

Here the user can enter the IP address directly into the box highlighted in red. If the unit is on a network with a DHCP server, the user must use the Auto Discovery mode.

2.2.3 STVI Ethernet Port

STVI Ethernet Port is a 10/100BaseTX PoE (Power over Ethernet) port, which is the STVI connection port. This port provides power to the STVI using POE (Power Over Ethernet), and manual control of the MPRT8445 unit with the STVI.

2.2.3.1 Setting MPRT8445 IP Address for Operation with STVI

With the Ethernet cable supplied with the unit, connect the **STVI** Ethernet Port on the MPRT8445 front panel to the Ethernet port on the top of the Smart Touch View Interface (STVI). As the MPRT8445 unit goes through its power up sequence, in less than a minute the STVI power up screen will appear. The STVI will auto-detect the MPRT8445 (does not require the user to input an IP address). Once it auto-detects the unit, and determines the configuration of the

MPRT8445 unit connected, the Manual screen will appear.

2.2.3.2 Setting MPRT8445 IP Address for Networks or IEC 61850 Operations

 The MPRT8445 maybe controlled over a network. This provides remote control of the MPRT8445 virtually over any distance allowing one PC to control at least two units simultaneously, such as in end to end testing.

 Connecting the MPRT8445 to a Local Area Network or a Wide Area Network could permit unauthorized operation of the unit.

Through the PC IN Ethernet port, the MPRT8445 integrates into a network just like a PC or server. To use this feature requires the user to setup the IP configuration of the MPRT8445 for their LAN. Note that the MPRT8445 when turned on will automatically search for and acquire a network address if connected to a network. If it fails to automatically acquire an address check to make sure you are properly connected using a standard Ethernet cable. **Do not** use a cross over

Ethernet cable (a cross over cable is designed for use from your PC to the test set, not to a network). If the unit still fails to acquire an address then there may be other issues. This will probably require assistance from your company's information management department. For IEC 61850 testing connect the PC IN port to the substation bus or to the relay under test to receive and send GOOSE messages.

! When connecting the MPRT8445 to an IEC 61850 network, for PC control use the USB port to program and control the MPRT unit. Connecting the PC to the USB port provides a secure port, where the operator cannot accidentally trip off the substation, or infect a PC virus into the substation LAN, and sniff the network through the PC IN Ethernet port.

When used with the Megger GOOSE Configurator in the AVTS software, the MPRT8445 can provide high speed testing of IEC 61850 relays and substations by subscribing to GOOSE messages and mapping to the binary inputs. In addition, it can simulate system conditions such as circuit breaker operation by publishing GOOSE messages mapped to the MPRT8445 binary outputs. With the PC connected to the OUT port, and running AVTS Megger GOOSE Configurator software, the operator can "sniff" the substation network.

3.0 Current Sources

3.1 Parallel Operation

Each MPRT8445 current amplifier is capable of providing 30 Amperes continuous, and up to 45 amperes for 1.5 seconds for testing instantaneous trip elements. When more than 30 amps single phase is required for long durations, or 45 Amps for testing instantaneous elements, three or more current channels may be connected in parallel to provide 90 up to 120 Amperes continuous, and up to 180 amperes for short durations.

! Note: If an **F** appears in the 3rd digit of the style identification number (i.e. XX**F**XXXXX) the current returns are floating (isolated from each other and ground). Those units with a style number **G**, the current returns are common together internally and connected to earth ground.

To parallel the current channels of the unit, perform the following:

If using the sleeved multi-lead current test leads (part number 2001-396), all of the black return leads are interconnected together inside the sleeve so they will all share the return current together. Connect each current channel to the relay under test (both red and black terminals to the load). Each Megger test lead is rated for 32 Amperes continuous. If using test leads other than those supplied by Megger insure that the wire has sufficient size to carry the test current.

! For the earth grounded common return (G) units, there is an internal common ground between the current channel return terminals. If using separate individual test leads, all of the return leads will need to be common together at the load as shown in the following figure. By not connecting a return lead to all of the current channels in use, part or all of the return current will be forced through the internal ground. That means with 4 channels in parallel up to 180 Amperes could be forced through the internal common ground, and will cause damage to the internal common returns. Therefore, it is important that the parallel connections must be made at the relay. See the following figure.

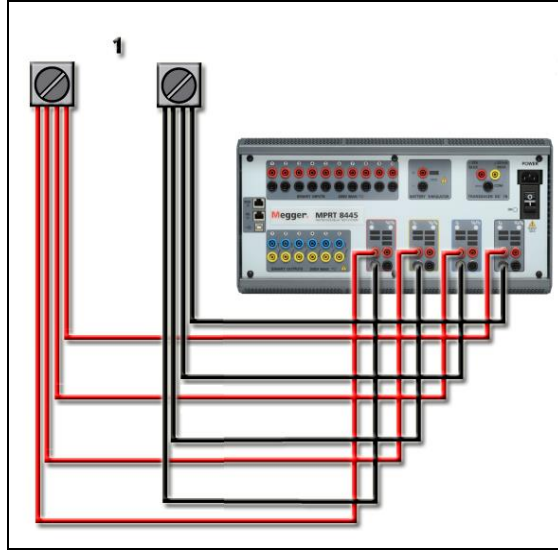

Figure 145 Parallel of Four Current Outputs

3.1.1 Manual Test Screen - Single Phase Up To 240 Ampere

For ease of use and operator convenience, go to the Configuration screen and select the Operating Mode of **3 Voltages – 1 Current or 4 Voltages – 1 Current**. When you return to the manual test screen there will be one current channel displayed, as shown in the following figure.

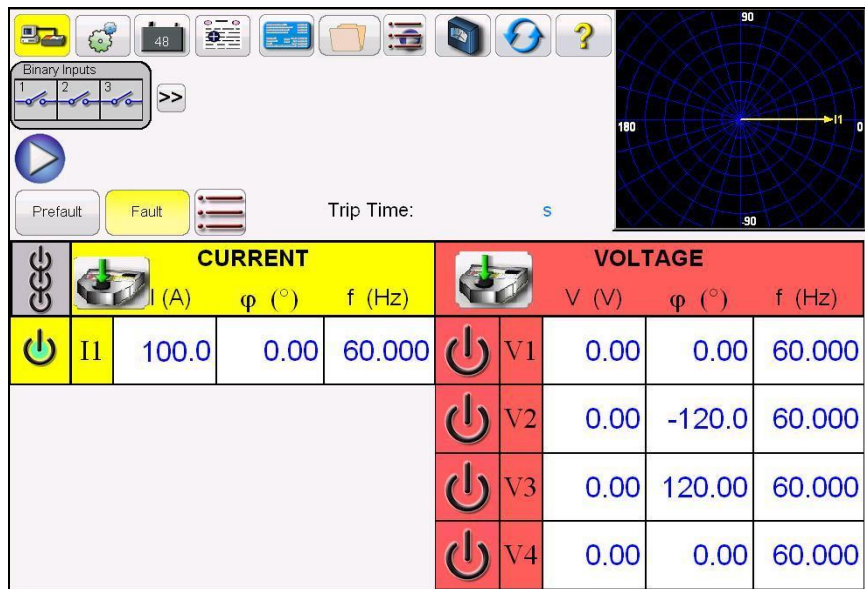

Figure 146 Manual Test Screen – 4 Voltages and Single Phase Current Operation

The STVI will automatically set all currents in phase with each other and divide the current equally between the current amplifiers. When setting an output, simply enter the value of the desired output current. For example, for an output of 100 Amperes, enter 100. For a four channel unit each current amplifier will be providing 25 Amperes. The current can also be phase shifted. Simply enter the desired phase angle and all currents will be phase shifted together.

If two current channels that are to be used in parallel, leave the unit in the default configuration. Connect the two current outputs to the load as shown in the following figure.

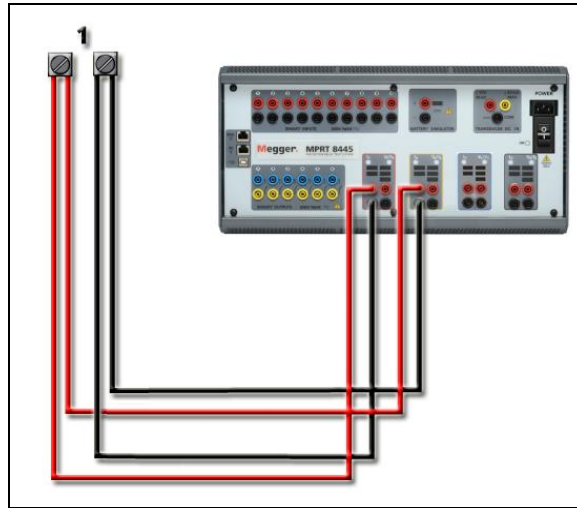



Figure 147 Two Currents in Parallel

Set each channel to one-half of the output requirement. Be sure and reset current channel #2 to 0 degrees so that it will be in-phase with current channel #1. With both current channels selected, turn output on by pressing or clicking on the ALL ON/OFF button. Always use the ALL ON/OFF button to turn both current channels on and off together. For manually ramping outputs, if using the PC version of the STVI software the $\uparrow\downarrow$ buttons will be displayed. If using an STVI controller the Control Knob icon  will be displayed. Pressing either of these two will present the user with a window to select the desired level of increment for manually ramping the outputs, the desired channel(s) to be ramped, and what is to be adjusted (amplitude, phase angle or frequency).

3.2 Currents in Series Operation

Two current channels may be connected in series in order to double the available compliance voltage. High impedance electromechanical ground (earth) overcurrent relays have always been difficult to test at high multiples of tap due to the winding impedance and saturation characteristics. The peak voltage required can exceed the maximum output voltage of one MPRT8445 current output channel, depending on the required test current. By connecting two current outputs in series, the compliance voltage is doubled, providing higher test currents through the load. There are two methods to series currents together. For the floating output (F) models connect the two current amplifiers in a “push-push” configuration as shown in the following figure.

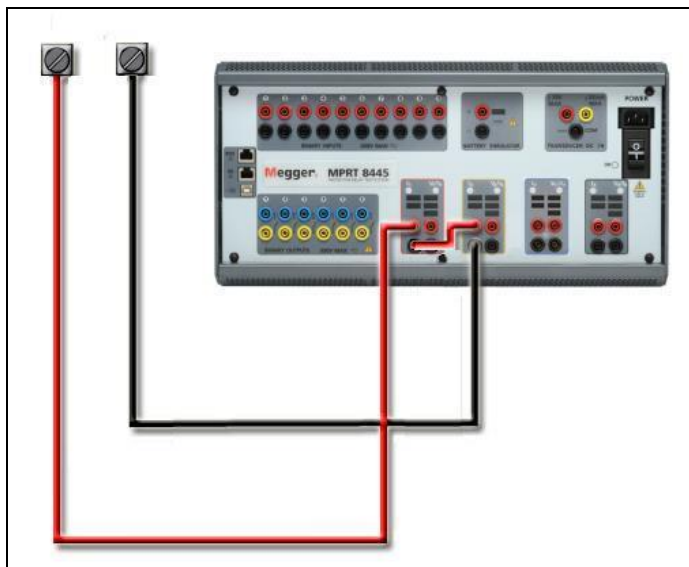



Figure 148 Series Two Currents with Floating Output Unit

The two current channels that are to be used in series set each to the same test current magnitude, and phase angle. Select both current channels and turn output on by pressing or clicking on the ALL ON/OFF button. Always use the ALL ON/OFF button to turn both current channels on and off together. For manually ramping outputs, if using the PC version of the STVI software the $\uparrow\downarrow$ buttons will be displayed. If using a STVI controller the Control Knob icon  will be displayed. Pressing either of these two will present the user with a window to select the desired level of increment for manually ramping the outputs, the desired channel(s) to be ramped, and what is to be adjusted (amplitude, phase angle or frequency).

To series the current channels of the common grounded returns (G) unit, perform the following:

Using the current channel test leads, connect the Red output terminals of the two current channels to the relay under test. Even though the two returns associated with the current channels are connected internally with the common returns, place a jumper as shown. This will insure that the internal common leads will not be damaged.

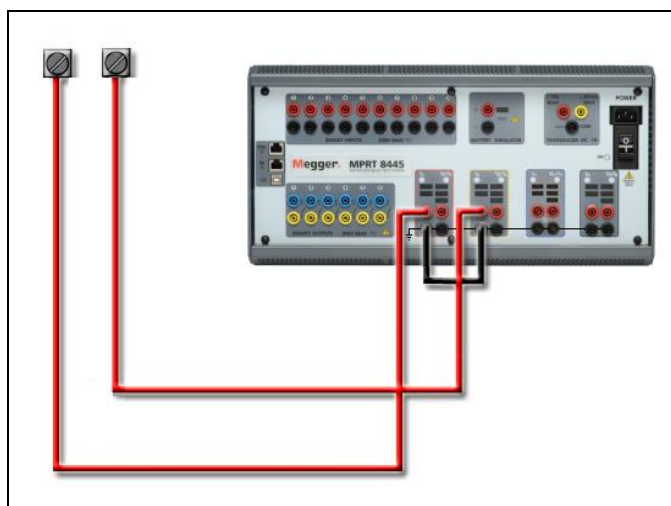



Figure 149 Series of Two Current Channels with Grounded Common Returns

! NOTE: One current channel should be set to 0 degrees and the other current channel should be set to a phase angle of 180 degrees so that the two compliance voltages add across the load. DO NOT attempt to series more than two currents together on a grounded common returns unit.

The two current channels that are to be used in series set each to the same test current magnitude. Initiate the two current channels simultaneously by pressing the ALL ON/OFF button. Always use the ALL ON/OFF button to turn both current channels on and off together. For manually ramping outputs, if using the PC version of the STVI software the $\uparrow\downarrow$ buttons will be displayed. If using an STVI controller the Control Knob icon  will be displayed. Pressing either of these two will present the user with a window to select the desired level of increment for manually ramping the outputs, the desired channel(s) to be ramped, and what is to be adjusted (amplitude, phase angle or frequency).

4.0 Voltage Sources

4.1 Outputs Summed Together

Two voltage channels may be used to sum the voltage outputs to obtain higher than rated voltage provided the load is ungrounded. Connect the load between the voltage channel posts, set V_1 Phase to 0° and set V_2 Phase to 180° . The voltage outputs will add so the total voltage is the sum of the two voltage amplitudes, V_1 and V_2 as can be seen in the picture below.



! Note: If an **F** appears in the 3rd digit of the style identification number (i.e. XX**F**XXXXX) the voltage returns are floating (isolated from each other and ground). Those units with a style number **G**, the voltage returns are common together internally and connected to earth ground.

For the floating common units the user must connect the associated voltage channels black common returns together, when series operation is required (see the following figures). Remove external commons when testing is completed.



DO NOT attempt to series more than two voltage channels together. The test leads are rated for 600 Volts.

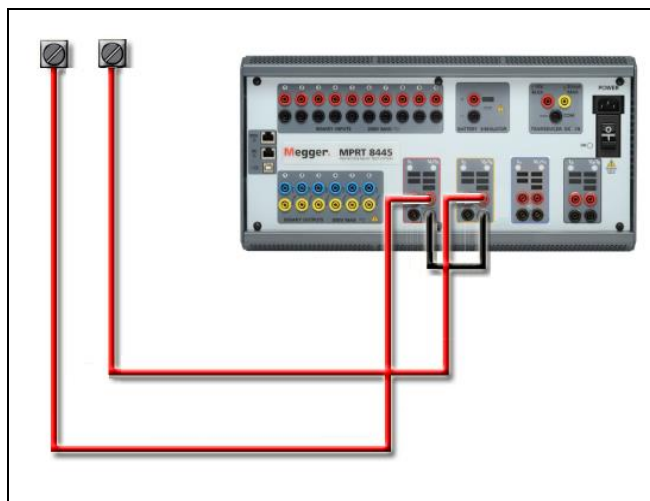

Figure 150 Series of Voltage Channels for Floating Ungrounded Common Returns

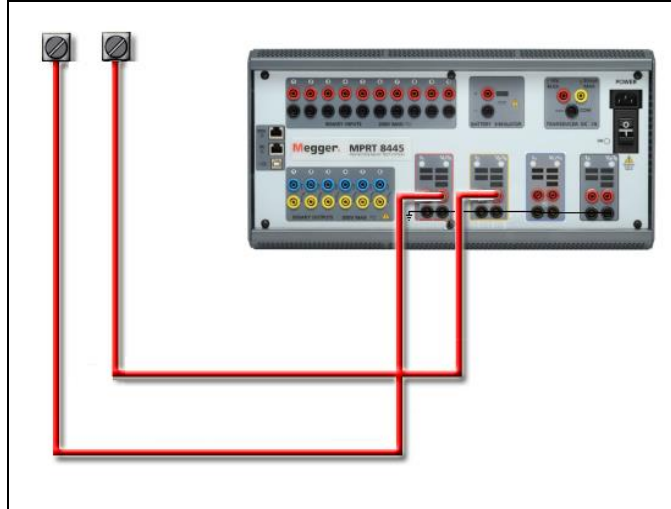

Figure 151 Series of Voltage Channels with Grounded Common Returns

4.2 3Ø, 3-Wire, Open-Delta and T-Connection

4.2.1 Balanced Open Delta

Two methods of obtaining a three-phase, three-wire voltage source are available. The Open-Delta configuration is the easier to use when a balanced three-phase source is required because the amplitude and phase relationship can be set directly. No calculations are necessary.

When using the Open-Delta configuration, it is suggested to use voltage channel #1, designated V_1 , and voltage channel #2, designated V_2 , while the COMMON binding post is designated V_g . With this arrangement, the magnitude and phase angle of the potentials can be easily calculated and set. For the balanced three-phase condition V_{1g} and V_{2g} are equal in magnitude and separated by an angle of 60° . This is done by setting the V_1 and V_2 potentials equal in magnitude, setting 0° on V_1 and 300° (60 degrees leading assuming that the default phase rotation is set to 360 Lag) on V_2 , see the following figures.

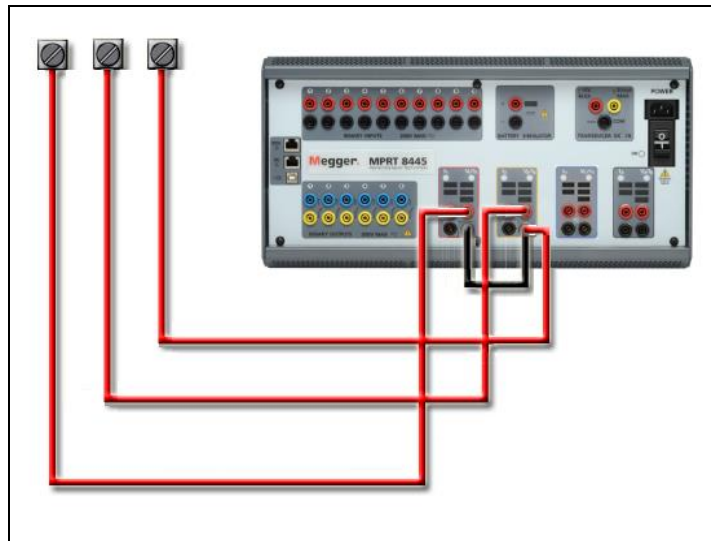
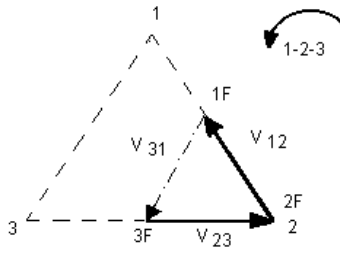

Figure 152 Three Phase Open Delta Connections

When using the Open-Delta Configuration to set up a phase-to-phase fault, calculations' using the Law of Cosines is required to calculate amplitude and phase relationships. (See discussion

under T-Connection for simulating unbalanced, phase-to-phase faults without need for calculations.)



Balanced 30 - Open Delta Connection
If V_f equals the desired test potential, then:
Set $V_1 = V_f \angle 0^\circ$
Set $V_2 = V_f \angle 300^\circ$ Lagging (60° Leading)

4.2.1.1 Unbalanced Open Delta

When setting up an Unbalanced Open-Delta configuration, the desired phase-to-phase fault voltage, V_{1f} is set using voltage channel #1 with its phase angle set to 0° . Phase-to-phase voltage V_{2f} and its phase angle relationship for voltage channel #2, must be calculated using the Law of Cosines; where For any triangle the following formula applies:

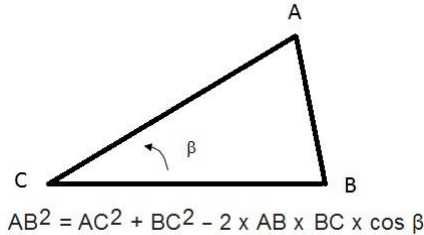

The next figure shows the phase relationships between voltages and an example of the necessary calculation. For convenience the amplitude and the phase angle settings for the typical V_f fault magnitudes are tabulated.

From the Law of Cosines

$$\theta = \arccos\left(\frac{V_{12}}{2 * V_{23}}\right)$$

$$V_{23}^2 = \left(\frac{V_{12}}{2}\right)^2 + \left(\frac{\sqrt{3}}{2} * 120\right)^2$$

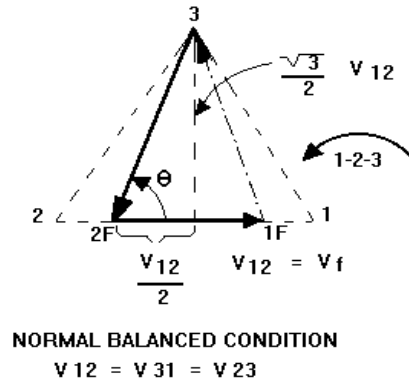

Figure 153 Open-Delta Unbalanced phase-to-phase Fault Voltages

Settings for Typical Phase-to-Phase Fault Voltages

$$V_{12} = V_{\text{fault}}$$

V_{12}	1	5	10	15	20	25	30	35	40	45	50	55	60	65	70
V_{23}	104	104	104	104	104	105	105	105	106	106	106	108	108	109	110
At θ° Lag	270	271	273	274	275	277	278	280	281	282	284	285	286	287	289

4.2.2 T Connection

The second method of obtaining a three-phase, three-wire voltage source is the so-called T-Connection. The method, shown in the following figure, is easier to use when obtaining an unbalanced, phase - to -phase fault simulation since it eliminates calculations. To reduce confusion when using the T-Connection, the voltage output #1 is designated V_a and its phase angle set at 0° , voltage output #2 is designated V_b and its phase angle set for 180° , and voltage output #3 is designated V_c and its phase angle is set for 270° . Any combination of balanced three phase faults or unbalanced phase-to-phase fault conditions can be easily simulated. The following figure indicates these phase relationships.

!NOTE: This method should not be used for very low fault voltages, or used on solid state relays that may be sensitive to this type of connection (i.e. 5 volts or less, or for testing ABB or Westinghouse type SKD relays).

$$V_f = \text{Desired Fault Voltage}$$

$$V_a = \frac{1}{2}V_f \angle 0^\circ$$

$$V_b = \frac{1}{2}V_f \angle 180^\circ$$

$$V_c = \frac{\sqrt{3}}{2} 120 \text{ or } V_c = 104V \angle 270^\circ$$

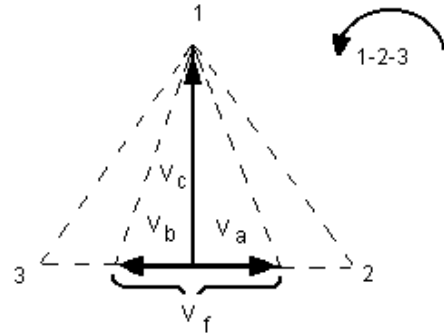

Balanced or Unbalanced Fault T-Connection

4.3 3Ø, 4-Wire, Y-Connection

A three-phase, four-wire potential system can be provided using three output modules. The vector relationships are referenced below. This Y-Connection has the advantage of being able to supply a higher line-to-line voltage (1.73 x phase-to-neutral voltage). It is ideally suited for simulating phase-to-ground faults. Voltage channel #1 is designated as V_a with its phase relationship set for 0° . Voltage channel #2 is then designated as V_b and phase angle set for 120° . Finally, voltage channel #3 is designated V_c and phase angle set for 240° (for a 1-2-3 counter clockwise rotation). V_a , V_b and V_c are connected to the voltage potential binding posts on the respective test sets.

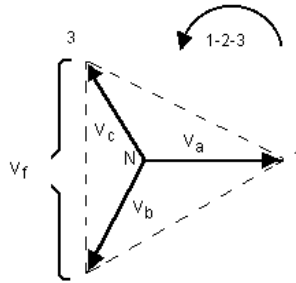

Balanced 3 ϕ , 4 Wire Y-Connection

$V_f = \text{Desired Fault Voltage}$

$$V_a = \frac{\sqrt{3}}{3} V_f \angle 0^\circ$$

$$V_b = \frac{\sqrt{3}}{3} V_f \angle 120^\circ$$

$$V_c = \frac{\sqrt{3}}{3} V_f \angle 240^\circ$$

! Note: If an **F** appears in the 3rd digit of the style identification number (i.e. XX**F**XXXXX) the voltage returns are floating (isolated from each other and ground). Those units with a style number **G**, the voltage returns are common together internally and connected to earth ground.

If using the sleeved multi-lead voltage test leads (part number 2001-395), all of the black return leads are interconnected together inside the sleeve so they will all share the return together. Therefore, only one return lead is provided on the relay connection side of the sleeved leads (similar to the connections in the following figure).

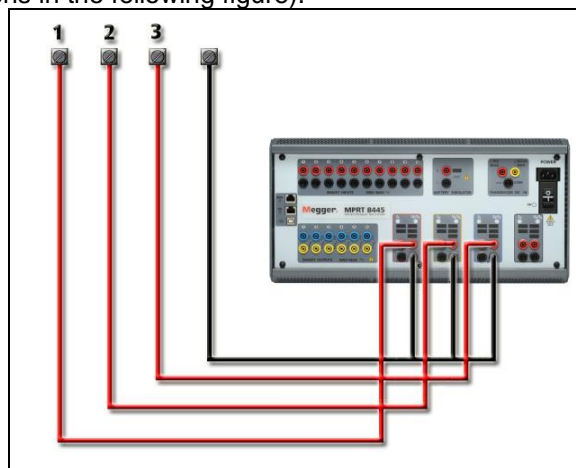

Figure 154 Three Phase Four Wire Test Connections

! For the earth grounded common return (G) units, there is an internal common ground between the voltage and current channel return terminals. Therefore, only one return lead is required for the voltage channels. If using separate individual test leads, for the floating common units the

user must connect the associated voltage channels black common returns together as shown above.

5.0 Warranty Statement

Megger warrants the product is free of defects in material and workmanship for a period of one (1) year from date of shipment. This warranty is non-transferable. This warranty is limited and shall not apply to equipment that has damage, or cause of defect, due to accident, negligence, and improper operation, faulty installation by the purchaser, or improper service or repair by any person, company or corporation not authorized by Megger. Megger will, at its' option, either repair or replace those parts and/or materials it deems to be defective.

The warranty is in lieu of all other warranties, either expressed or implied on the part of Megger and in no event shall Megger be liable for the consequential damages due to the breach thereof.

5.1 Preventive Maintenance

The unit utilizes surface mount technology (SMT) and other components which require little or no service except for routine cleaning, etc. The unit should be serviced in a clean atmosphere away from energized electrical circuits.

5.1.1 Examine the unit every six months for:

Dust and Dirt	To clean the unit, disconnect the power cord from the unit. Never use spray liquids or industrial cleaners. Some cleaning solvents can damage electrical components, and should never be used. Water and a mild soap may be used. Use a lightly damp cloth (not dripping wet) to wipe off the unit. A dirty heat sink can cause thermal overloads. Remove dust with dry, low pressure, compressed air. Either remove the module from the chassis or simply apply air forcing the dust away from the heat sink through the sides of the unit.
Moisture	Remove moisture as much as possible by putting the test set in a warm, dry environment.

5.2 Updating MPRT8445 Firmware

Download Firmware Upgrade via Megger Website

To download the newest firmware from the Megger website,

1. Go to WWW.Megger.com
2. **Log In.**
3. Go to **Software Downloads**
4. Click on **MPRT8445**
5. Click in the window provided and enter the MPRT8445 Serial Number. Note: Make sure you enter the serial number correctly, or it may be rejected.
6. Click on **Firmware Version #.##.** **Note: the MPRT8445 uses the same firmware as the SMRT units, thus it will have a file name SMRT_Firmware_Version #.ldr.**

The firmware will be downloaded onto the user's PC as a zip file. Create a folder and Extract (unzip) the file to the folder.

Firmware Upgrade via STVI USB Port

Download the firmware to your PC from the Megger website as outlined above, see Firmware Upgrade via Megger Website. Unzip the file, **Select All** files, and **Copy** to a USB memory stick. Interconnect the STVI to the MPRT8445 unit via the Ethernet cable, and power up the test system. Then insert the USB stick into the USB port on the top of the STVI. To perform the upgrade, from the STVI **Configuration Screen** press the **Update Firmware** button. The MPRT8445 will automatically look to see if the firmware is a newer version of Software /Firmware, and if it is, it will automatically download the firmware into the unit.

5.3 Service and Repair Instructions

To save turn-around time and reduce costs, MPRT8445 was designed as a modular unit. In most cases, if any one module should experience a problem it should not cause the test system to be down. Basic troubleshooting information has been provided to guide the technician to the possible source of a problem.

Since MPRT8445 uses Surface Mount Technology, most repairs of the individual modules are beyond the scope of the basic troubleshooting guide, and should be referred to the Service Department at Megger or handled through the Megger Representative.

 If the unit is still within the original warranty period, or limited warranty period following factory servicing, **the factory must be contacted before attempting any repairs or the warranty will be void.**

5.3.1 Basic Troubleshooting

The troubleshooting information relies on the technician to have a good understanding of the operation of the unit. If the technician is unfamiliar with the unit, he or she should not attempt to repair. The technician should contact the factory before attempting repairs. Provide the Megger part number for the part or assembly in question and the serial number of the MPRT8445 when making inquiries.

 **WARNING** It is necessary to energize the MPRT8445 to properly troubleshoot some of the modules. The technician must take all applicable safety precautions for working near energized circuits.

NOTES

Before suspecting a failure in the MPRT8445, review the General Description and Operation sections to ensure that the problem is not a result of operating error.

Preliminary testing of the MPRT8445 within its specified limits can help determine if a malfunction actually exists, identify the type of malfunction and define the general area of the failure.

Common causes of malfunctions, other than improper operation, are incorrect power input (voltage above or below specified limits), incorrect test signal voltages applied to the Binary Input gates (outside of the specified AC/DC Applied/Removed limits), and contact or circuit resistance too great for the Dry Contact gates to operate properly on the Monitor/Start/Stop gates. Typical malfunctions for the VI-Gen amplifiers are external short circuits on the voltage output and open circuits on the current output. The battery

simulator and VI-Gen voltage and current outputs can be easily checked using a voltmeter and ammeter.

 **NOTE:** There are three different modules that can make up a MPRT8445; the TCM Board (front panel), VIGEN's (VIGEN#1, and #2) and VIGEN's LITE (VIGEN #3, and #4). Most problems can be easily resolved by replacement of one of these modules, see section **5.3.1.2.1 Replacing a VIGEN** for instructions on how to replace a VIGEN module. Proper ESD procedures should be followed when handling any MPRT8445 module. Failure to do so, may damage sensitive parts.

5.3.1.1 Power Input

Input voltage affects the whole unit and may or may not cause permanent damage if voltage is incorrect. These problems can often be corrected by simply using a better source of input power. The rated voltage limit is auto-selectable from 120 to 240 volts, $\pm 10\%$, 47 to 63 Hz.

Some symptoms are as follows:

1. Low voltage: Erratic operation, no output, input power circuit breaker operation.
2. High voltage: Circuit breaker operation, power supply failure in Input Power Module.

5.3.1.2 VIGEN Input Power, Communication and Control

Basic troubleshooting of the input power is as follows.

1. No power: Check the ON/OFF circuit breaker. Does the power ON light up? If it does not light up, then power is not getting to the unit. Check power source and line cord. If it lights up then the power is getting to the unit. Check the VIGEN power cable connection.



CAUTION: Turn off main power and unplug line cord before attempting to work on any module. Observe proper Electro Static Discharge procedures.

- A. Disconnect the power cord from the unit.
- B. Remove the twelve Phillip head screws, 4 on each side, and 4 on the top-back that hold on the top cover.
- C. Remove the top front center screw on the front panel, and the two screws (one on each side) of the front panel that connects the top cover to the front panel.
- D. Remove the top cover from the enclosure.

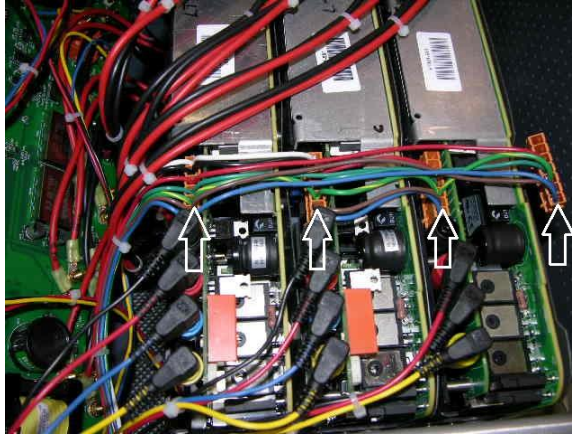

Figure 155 VIGEN Power Connectors for 3 Channel Unit

Check the cables as shown. If the cables are properly connected, then remove and replace the VIGEN per 1.5.3.1.2.1.

2. Erratic Manual Control

Individual Output Module communication cable is not properly connected thus cannot receive proper commands. Look through the air intake holes of the unit to observe the VI-Gen LED's. Each module has some green LED's that blink. These are associated with the Ethernet communications. If there are no blinking LED's on one or more modules, then the module is not communicating. Remove the top cover using the procedure described above.



CAUTION: Turn off main power and unplug line cord before attempting to reseat any cables. Observe proper ESD procedure.

Locate the communication Ethernet cables on the left side, see the following figure.



Figure 156 Communication Cable Connections 3 Channel Unit

Carefully disconnect each cable and reconnect to insure the cable locks into position. Note: In order to reseat each communication cable the small wire-ties will need to be removed (replacement wire-ties will be required after reseating the cables).

After reseating the cables, reinstalling the top cover assembly, reconnect the power cord and power up the unit. Look through the air intake holes on the left side of the unit to observe the VI-Gen LED's. If there is still no blinking LED's on one or more modules, and then replace the VI-Gen Module(s) that are not communicating. If they are not lit, then remove the power cord and the top cover and check the power connection cables to each VIGEN as described in Step 1 above.

5.3.1.2.1 Replacing a VIGEN

1. To remove the VIGEN, on early units there are three Phillip head screws that hold in the VIGEN, one on each side and one on the bottom of the unit.
2. Remove the power connection cable as shown in Figure above.
3. Disconnect the communication cables as described for Figure above.

ⓘ Note the small cables that connect the front panel board to VIGEN 1 need to be carefully removed prior to removing VIGEN1, see the following figure.



Figure 157 VIGEN1 to Front Panel Cable

4. Carefully remove the VIGEN module from the chassis.
5. Install replacement VIGEN.



Be careful when replacing the module as it is a tight fit, and it is possible to damage components upon extraction or installation.

6. Replace the Phillip head screw(s) that hold in the VIGEN.
7. Reconnect the power connection cable as shown in Figure above.
8. Reconnect the communication cables as shown in Figure above. Replacement wire-ties will be required after reseating the cables.
9. If VIGEN #1 was replaced, reconnect the front panel ribbon cable as shown in Figure above.
10. Reinstall the top cover. Reconnect the power cord and power up the unit.

5.3.1.3 Binary Inputs, Binary Outputs and Battery Simulator

If all the items external of the Timer assembly are in proper order, then the problem exists within the Binary Input / Output assembly itself.

Some basic troubleshooting can pinpoint problems to the approximate cause.

Binary Inputs - Basic troubleshooting is as follows:

1. Timer does not stop:
Jumper the appropriate Binary Input terminals manually. If LED above the selected input lights, check the Binary Input setup screen to verify that the selected binary input is properly setup as a Timer stop post. Check Timer stop

settings as N.O. (Normally Open) to close, and Latch On. If LED does not light up, the Binary Input will need to be repaired or replaced.

2. Counting errors:
AC applied or removed Stop signals can create, what appears to be poor repeatability, an inaccuracy or a malfunction in the Timer. The lower the voltage level, the more serious the "error" will be. What appears to be an error, however, is actually a variation in the point on the sine wave at which the voltage is great enough to cause the gate circuit to operate. If the circuit used for the timing test has a low AC voltage and the point at which the contact in the test circuit opens or closes, is at or close to zero on the sine wave, the period of time before the voltage level will be high enough to trigger the gate circuit can be as much as 4 milliseconds. The total timing variation can be as much as 8 milliseconds. The shorter the duration of the timing test, the more significant the variation becomes. Therefore, if small timing variations would present a problem, it is recommended that an AC voltage of 115 volts or above or a DC voltage be used for voltage applied/removed test selections.

When the MPRT8445 Timer calibration is being tested, the AC voltage variable is often overlooked. This is particularly true when the Timer is compared to a counter and the two are triggered simultaneously with an electronic switch. For best results, a DC voltage should be used to eliminate the variable. If testing the AC voltage Timer Stop characteristics is desired, then the Stop signal must be triggered at the same point on the sine wave to assure that the gate signal will be repeatable. Ideally, the signal should be at a point near peak in the positive direction. In addition, the specified rms AC voltage values for the various Stop control selections must be adhered to.

Another source of apparent "error" can be the programmable de-bounce feature. If using electro-mechanical contacts for stopping the Timer, and if those contacts have a tendency to bounce, there could be a difference between an external standard timer and the MPRT8445 Timer, depending on the programmed de-bounce period set in the MPRT8445 unit. To determine the programmed value, look at the Binary Input Setup Screen and see what the De-bounce setting value is.

If a timing error or variation persists after all the suspected causes of error have been eliminated, then it is possible that the Binary Input circuit is malfunctioning. Contact factory for return instructions.

Binary Outputs - Basic troubleshooting is as follows:

Binary Output LED is ON but output contacts **not closed**:

Using a continuity tester check to see if output circuit is open circuited. If circuit is open then it is possible that the internal surface mounted fuse element has been blown. Note: an optional in-line fused test lead Part Number: 568026 are available to provide protection from switching too high current, see MPRT8445 Ordering Information under Optional Additional Accessories. The unit will need to be returned to the factory for further inspection and repair.

 Contact the factory for a Repair Authorization Number and return instructions if service is required. A Repair Authorization (RA) number will be assigned for proper handling of the unit when it arrives at the factory. Any non-warranty repair cost incurred for the repair or replacement of parts and/or materials shall be the responsibility of the purchaser.

Provide the factory with model number, Unit serial number, serial number of VI-Gen if appropriate, nature of the problem or service, return address, your name, and how to contact you should the factory need to discuss the service request.

You may need to provide a purchase order number, cost limit, billing, and return shipping instructions. If an estimate is requested, provide the name and contact information.

6.0 Preparation for Reshipment

 Save the original shipping container for future use. The shipping container is designed to withstand the rigors of shipping via a common commercial carrier. For example, you may wish to reship your unit to Megger for an annual calibration recertification.

Pack the equipment appropriately to prevent damage during shipment. If a reusable container is utilized, the unit will be returned in the same shipping container if it is in suitable condition.

Add the Return Authorization Number to the address label of the shipping container for proper identification and quicker handling.

 **NOTE:** Ship the equipment without nonessential items such as test leads, etc. These items are not needed by the factory to perform service.

Addendum E









Model MPRT2145 **Megger Single Phase Relay Tester**

SAFETY PRECAUTIONS

WARNING: VOLTAGES GENERATED BY THIS INSTRUMENT CAN BE HAZARDOUS

This instrument has been designed for operator safety; however, no design can completely protect against incorrect use. Electrical circuits are dangerous and can be lethal when lack of caution and poor safety practices are used. There are several standard safety precautions that should be taken by the operator. Where applicable, IEC safety markings have been placed on the instrument to notify the operator to refer to the user manual for instructions on correct use or safety related topics. Refer to the following table of symbols and definitions.

Symbol	Description
===	Direct Current
~	Alternating Current
⎓	Both direct and alternating current
	Earth (ground) Terminal. There is a common chassis ground terminal located on the front panel (see Front panel under Description of Controls).
	Protective Conductor Terminal
	Frame or Chassis Terminal
	On (Supply)
○	Off (Supply)
	Caution, risk of electric shock
	Caution (refer to accompanying documents)

 **WARNING:** Under no circumstances should the operator or technician attempt to open or service this instrument while connected to a power source. Lethal voltages are present and may cause serious injury or death!

SAFETY PRECAUTIONS (Continued)

The following are some specific safety related items associated with the MPRT2145 test system.

Read and understand all safety precautions and operation instructions before attempting to use this unit.

The purpose of this equipment is limited to use as described in this instruction manual. Should a situation arise that is not covered in the general or specific safety precaution please contact Megger regional representative or Megger, Dallas Texas.

Safety is the responsibility of the user. Misuse of this equipment can be extremely dangerous.

Always start with the power OFF, before connecting the power cord. Make sure outputs are off before attempting to make test connections.

Never connect the test set to energized equipment.

Always use properly insulated test leads. The optional test leads are rated for the continuous output ratings of the test system, and should be properly used and cared for. DO NOT use cracked or broken test leads.

Always turn the test system off before disconnecting the power cord.

DO NOT attempt to use the unit without a safety ground connected.

DO NOT attempt to use the unit if the power cord ground prong is broken or missing.

DO NOT use the test set in an explosive atmosphere.

The instrument must only be used by suitably trained and competent persons.

Observe all safety warnings marked on the equipment.

For safety related or other important topics, like the statement below, will be notated with the adjoined symbol. Read the topic carefully as it may relate either to the safe operation of the test system or the safety of the operator.



Under no circumstances should the operator put their hand or tools inside the test system chassis area with the test system connected to a power source. Lethal voltages are present and may cause serious injury or death!

1.0 Operation

The unit's design is a "modular" concept. All inputs and outputs are clearly marked and logically grouped so continual reference to the instruction manual should not be necessary once the operator is acquainted with the test system.

1.1 General Description

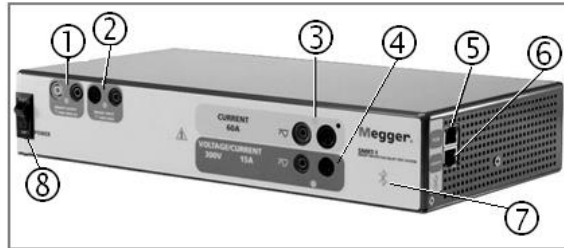

Figure 158 MPRT2145

1.1.1 Front Panel

1. **Binary Output** – the Binary Output can be configured as Normally Open or Normally Closed contacts providing logic to the device under test. The Binary Output can switch up to 300 VAC or 250 VDC with 8 Amp continuous. The programmable wait duration is from 1 millisecond to 10,000 milliseconds.
2. **Binary Input** –The Binary Input will accept a voltage range of 5 to 300 VAC, or 5 to 250 VDC, or dry Normally Open / Normally Closed contacts.
3. **Current Channel Output** – For more details on the VIGEN output capabilities see section 1.4.
4. **Voltage Channel Output** – For more details on the VIGEN output capabilities see section 1.4.
5. **PC/ IN** Ethernet Port is a 10/100BaseTX port, and is the primary PC connection port. This port supports MDI/MDI-X auto cross over configuration, which means both standard and “crossover” Ethernet cables may be used. This port provides the optimal method for downloading EMTP files, DFR streaming, and updating the unit’s firmware as required. The MPRT2145 comes standard with a crossover cable. This port may also be used for multiple unit operation, the unit providing the 61850/OUT link is providing the master phase reference to all units “downstream”.
6. **61850 / OUT** Ethernet Port is a 10/100BaseTX port, and is primarily used to interconnect multiple MPRT2145 units together for synchronous multi-unit operation. With the PC connected to the PC/ IN Port, the MPRT2145 61850 / OUT port may be connected to another MPRT2145 unit PC / IN port “downstream” providing phase synchronization through the Ethernet port. This port may also be used to provide access to the substation IEC 61850 network to receive and send GOSSE messages.
7. **Bluetooth** wireless port – this port is optional, and provides a wireless interface control with a PC. It also provides isolation between the IEC 61850 bus and the user PC.
8. **POWER ON/OFF Switch** – used to switch unit on and off. The switch illuminates when power is on.

1.1.2 Side Panel:

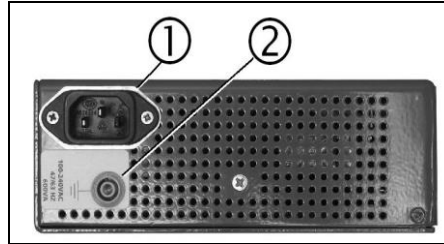

Figure 159 MPRT2145 Power Input Panel

1. **Incoming Power / Line Cord** – the input line cord, ground terminal, are mounted on the side panel of the test set.

Input Line Cord



The test set is equipped with a line cord, which connects to the male connector on the side panel. Verify the input voltage before connecting the line cord to the power source.

NOTE: The unit can be powered from an input source with a rating of 100 VAC to 240 VAC, 50/60 Hz. The unit automatically adjusts to the available power if it is within the specified range.

2. **Earth Ground Jack** – use this terminal to connect chassis ground to earth ground.



A chassis ground (earth) point on the front panel is provided as an additional safety ground.

1.2 Input Power

The input voltage may be from 100 to 240 VAC, 50/60 Hertz, 600VA. The input is protected by an ON/OFF switch / circuit breaker.

1.2.1. Input Power Cord

Depending on the country, the power cord can come with a NEMA 5-15 male connector, a CEE 7/7 Schuko two prong connector, a UK power cord, or with International Color Coded pig-tail wires (light blue, brown and green with yellow stripe) with the insulation jacket stripped ready for installation of the appropriate male connector.

Model MPRT2145 10NXXXAXXX comes with a North American power cord (part number 620000).

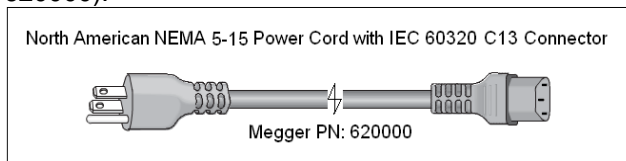

Model MPRT2145 10NXXXEXXX comes with a Continental Europe power cord (part number 50425).

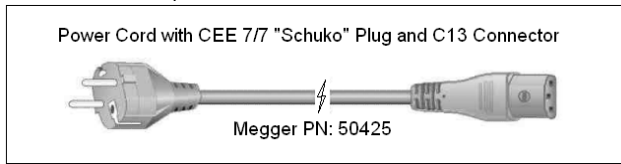

Model MPRT2145 10NXXXIXXX comes with an International Color Code power cord. The cord, part number 15065, is ready for wiring to the appropriate plug (depending on country). The following colors apply, Brown = Line, Blue = Neutral and Green/Yellow = Ground.

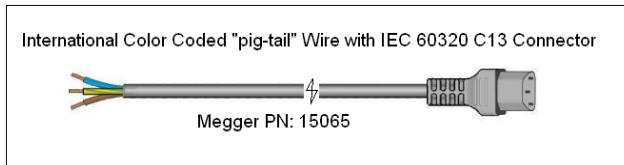

Model MPRT2145 10NXXXUXXX comes with a UK power cord (part number 90002-989).

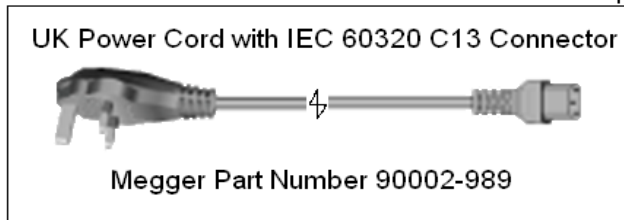

1.3 Voltage - Current Generators

Voltage and Current is noted by the red and yellow surrounding each output channel. The voltage channel is denoted by the red color. The current channel is denoted by the yellow color. All outputs are independent from sudden changes in mains voltage and frequency, and are regulated so changes in load impedance do not affect the output. All MPRT2145 amplifier outputs are isolated or floating.

1.3.1. Convertible Voltage/Current Amplifier

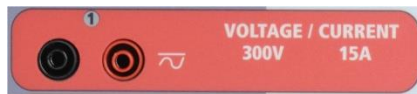

The MPRT2145 PowerV™ voltage amplifier provides a flat power curve from 30 to 150 Volts in the 150V range to permit testing of high current applications such as panel testing.

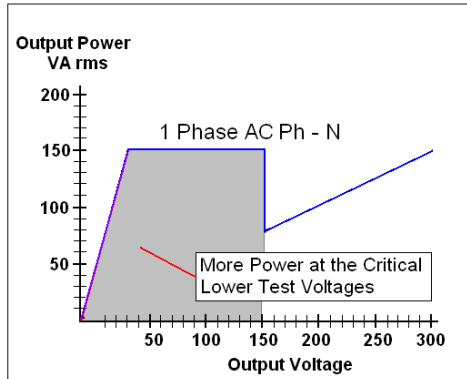

Figure 160 Voltage Amplifier Power Curve

Voltage Range

Power / Current (Max)

30.00V	150VA @ 5.0A
150.00V	150VA Constant Output Power from 30 to 150 Volts
300.00V	150VA @ 0.5A

Voltage Amplifier in Current Mode:

The voltage amplifier is convertible to a current source with the following output capability. Output power ratings are specified in rms values and peak power ratings.

Output Current	Power	Max V	Duty Cycle
5 Amperes	150 VA (212 peak)	30.0 Vrms	Continuous
15 Amperes	120 VA	8.0 Vrms	90 Cycles

The convertible channel in conjunction with the main current channel provides 2 currents for testing current differential relays one phase at a time.

[!] The voltage amplifier output is protected from short circuits and thermally protected against prolonged overloads. In case of a short circuit or a thermal overload, the amplifier will automatically turn off, and if the STVI is connected a message to the user will be displayed indicating which condition exists. If AVTS software is used, a similar message will appear.

1.3.2. Current Amplifier

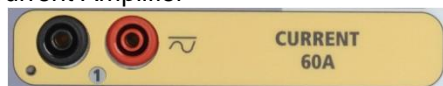

The MPRT2145 current amplifier delivers maximum compliance voltage to the load constantly during the test, and range changing is done automatically, on-the-fly, under load. This insures better test results, saves time by not having to turn the outputs off to change output taps or ranges, and unlike single range current amplifiers insures a higher compliance voltage at lower test currents. Constant power output in many cases eliminates the need to parallel or series current channels together to test high burden relays.

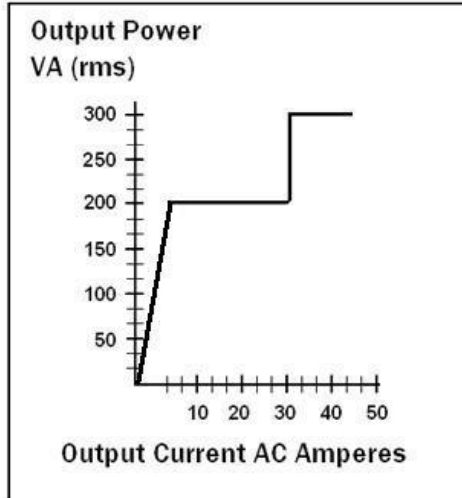

Figure 161 Current Amplifier Power Curves

The following are typical output current and associated available compliance voltage values. The output current and power ratings are specified in AC rms values and peak power ratings. Specified duty cycles are based upon typical room ambient.

Output Current	Power	Max V / Duty Cycle
1 Ampere	15 VA	15.0 Vrms Continuous
4 Amperes	200 VA (282 peak)	50.0 Vrms Continuous
15 Amperes	200 VA (282 peak)	13.4 Vrms Continuous
30 Amperes	200 VA (282 peak)	6.67 Vrms Continuous
45 Amperes	300 VA (424 peak)	6.67 Vrms 90 Cycles
DC 200 Watts		

! The current amplifier output is protected from open circuits and thermally protected against prolonged overloads. In case of an open circuit or a thermal overload, the amplifier will automatically turn off, and if the STVI is connected a message to the user will be displayed indicating which condition exists. If AVTS software is used, a similar message will appear.

1.4 Binary Input and Output



Figure 162 MPRT2145 Binary Input and Output

The MPRT2145 Binary Input and Output are clearly marked and logically grouped. The Binary Input is used to monitor relay trip contacts for performing pickup and dropout tests as well as for performing timing functions. The Binary Output is used to simulate normally open / normally closed contacts for testing breaker failure schemes, or similar power system operations. In addition they may also be used to switches AC/DC voltages and currents.

1.4.1 Binary Input

The binary input is specifically designed to measure high speed operation of electro-mechanical, solid-state and microprocessor-based protection relays. The binary Input defaults to Monitor Mode, Contact change of state, latched OFF. If using the STVI or STVI software to change a binary input from Contact change of state to Voltage Applied / Removed click on or touch the

Input Type window and a sine wave will appear where the Contact icon was indicating. The input is now set for voltage sensing. To change the binary input from Monitor mode to Timer Mode, click on or touch the Use as Monitor button and the display window will change to show Use as Trip, Latched, meaning the binary input is now set to stop the timer upon sensing the first contact closure (if the Input Type is set for contact) or upon sensing voltage if the Input Type is set to Voltage Sensing.

1.4.1.1 Start, Stop, and Monitor Gate

In the MPRT2145 the independent, programmable gate circuit permits simple selection of the desired mode for timing or contact monitoring operation.

To monitor operation of the contacts or trip SCR in the device under test, a light is provided for the gate. The gate circuit is isolated for voltage-sensing and can monitor solid-state logic signals. The light will illuminate once contacts close or voltage is applied to the gate.

1.4.1.1.1 Dry Contacts Open

Timer stops or a continuity indicator goes out at the opening of normally closed contacts, or when conduction through a semiconductor device, such as a triac or a transistor, is interrupted.

1.4.1.1.2 Dry Contacts Close

Timer stops or a continuity indicator glows at the closing of the normally open contacts, or upon conduction through a semiconductor device such as a triac or a transistor.

1.4.1.1.3 Application or Removal of AC or DC voltage

The continuity indicator will glow (application) or darkens (removal) upon the application or removal of either an AC or DC voltage. A higher threshold voltage helps to eliminate false triggers due to a noisy source. Lower thresholds allow stopping the timer from TTL voltage signals. The allowable voltage applied is 5 to 300 Volts AC or 5 to 300 Volts DC, current limiting resistors provide protection.

1.4.1.1.4 The Timer can be started when turning on any selected generators.

1.4.1.1.5 The Timer can be started simultaneously with a change in Frequency, Phase Angle, or Amplitude. Also, it can be started simultaneously with a Voltage or Current waveform step.

1.4.2 Binary Output

Binary Output is rated for 300 V at 8 Amps and a maximum of 2000 VA breaking capacity (80 watts DC), with a response time of less than 10ms. The Binary Output can be configured as normally open or normally closed contacts providing logic to the device under test. The programmable wait duration is from 1 millisecond to 10,000 milliseconds.

2.0 **SETUP**

2.1 Unpack System

Unpack the unit and check for evidence of any shipping damage. If there is any visual damage, immediately notify the freight carrier to make a damage claim, and notify Megger of the damage.



CAUTION:

Potentially lethal voltages may be present on the output terminals. It is highly recommended the operator read the user manual thoroughly and have an understanding of the test set operation prior to turning power on.

2.1.1 Initial Start Up

5. With the Ethernet cable supplied with the unit connect the **IN** Ethernet Port on the MPRT2145 unit to the Ethernet port on the PC Ethernet port. If using the STVI-2, connect the MPRT2145 **IN** port to the PoE power supply **Data In** port, and connect the **Data & Power Out** port to the STVI Ethernet port.
6. Before connecting power to the unit, make sure the POWER ON/OFF Switch is in the OFF position (O). Plug the unit line cord into an appropriate power source and turn the POWER ON/OFF Switch to ON (I). As the MPRT2145 unit goes through its power up sequence, in about a minute the STVI power up screen will appear, then the manual start up screen will appear.

2.2 Communication Ports

There are two Ethernet communication ports and an optional Bluetooth wireless port available on the MPRT2145. The ports are located on the right side on the enclosure.

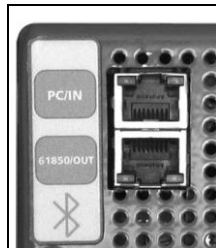



Figure 163 MPRT2145 Communication Ports

2.2.1 PC/IN Ethernet Port

PC/IN Ethernet Port is a 10/100BaseTX port, and is the primary PC connection port. This port supports MDI/MDI-X auto cross over configuration, which means both standard and “crossover” Ethernet cables may be used. This port provides the optimal method for downloading EMTP files, DFR streaming, and updating the unit’s firmware as required. This port may also be used for multiple unit operation, the unit providing the **61850/ OUT** link is providing the master phase reference to all units “downstream”. In addition, the port may also used to talk to the MPRT2145 unit via a Network.

2.2.1.1 Setting MPRT2145 IP Address for Operation with a PC

With the Ethernet cable supplied with the unit, connect the **PC/IN** Ethernet Port on the MPRT2145 unit to the PC Ethernet port. Turn the test set on. As the MPRT2145 unit goes through its power up sequence, in less than a minute the Binary Output LED will flash a number of times (see more information below). When the flashing has stopped the unit is ready. Using the PC version of the STVI software it will auto-detect the unit connected to the PC. Once it auto-detects the unit, and determines the configuration of the MPRT2145 unit connected, the Manual screen will appear. The unit might not auto detect due to firewall settings. In this case the firewall can be turned off or you can enter the IP address directly using the PowerDB instrument

configuration screen by clicking on the Instrument Setup icon on the PowerDB tool bar . From the Instrument Configuration Screen, shown in the following figure, click off the check mark in the Auto Discover Unit box.

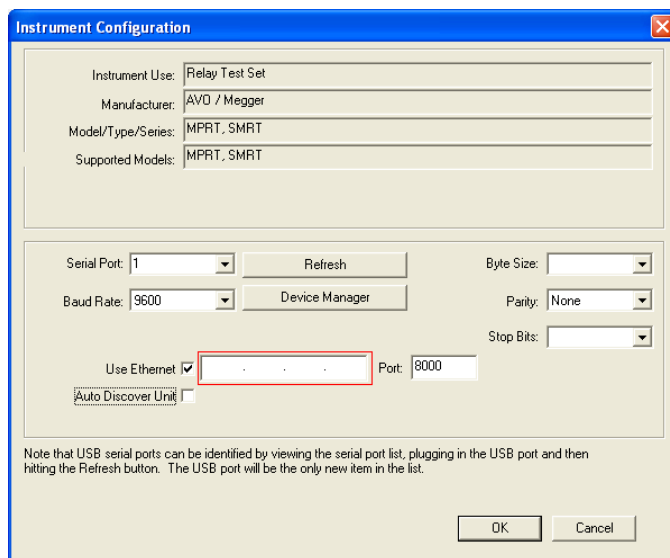

Figure 164 PowerDB Instrument Setup Screen

Here the user can enter the IP address directly into the box highlighted in red. The IP address of the unit can be determined by counting the number of times the Binary Output led flashes at the end of boot up cycle (the address is 169.254. <#flashes>.0). If the unit flashed four times, the address would be 169.254.4.0 . If the unit is on a network with a DHCP server, the user must use the Auto Discovery mode.

2.2.1.2 Setting MPRT2145 IP Address for Networks



The MPRT2145 maybe controlled over a network. This provides remote control of the MPRT2145 virtually over any distance allowing one PC to control at least two or three units simultaneously, such as in end to end testing.



Connecting the MPRT2145 to a Local Area Network or a Wide Area Network could permit unauthorized operation of the unit.

Through the IN Ethernet port, the MPRT2145 integrates into a network just like a PC or server. To use this feature requires the user to setup the IP configuration of the MPRT2145 for their LAN. Note that the MPRT2145 when turned on will automatically search for and acquire a network address if connected to a network. If it fails to automatically acquire an address check to make sure you are properly connected using a **standard** Ethernet cable. If the unit still fails to acquire an address then there may be other issues. This will probably require assistance from your company's information management department.

2.2.2 61850/OUT Ethernet Port

The OUT Ethernet Port is a 10/100BaseTX port, and is used when interconnecting multiple MPRT2145 units together. With the unit IN port connected to a PC, the OUT port would be connected to the “downstream” MPRT2145 unit IN port, providing phase reference to all downstream MPRT2145 units. Note that another MPRT2145 IN port could be connected to the OUT port of the upstream MPRT2145 unit, and so on thus creating a multi-phase test system. This port also provides access to the substation IEC 61850 network (when enabled) to receive and send GOOSE messages. The MPRT2145 with the IEC 61850 option enabled provides

selectable priority, VLAN-ID, and meets the IEC 61850-5 standard Type 1A, Class P 2/3, for high speed trip and reclose simulations.

2.2.2.1 IEC 61850 Operations

For IEC 61850 testing connect the IEC61850/OUT port to the substation bus or to the relay under test to receive and send GOOSE messages. When used with the Megger GOOSE Configurator in the AVTS software, the MPRT2145 can provide high speed testing of IEC 61850 relays and substations by subscribing to GOOSE messages and mapping to the binary input. In addition, it can simulate system conditions such as circuit breaker operation by publishing GOOSE messages mapped to the MPRT2145 binary output. With the PC connected to the MPRT2145 IN port, and running AVTS Megger GOOSE Configurator software, the operator can “sniff” the substation network. If a secure port is desired, with the optional Bluetooth wireless port, use the MPRT2145 to “sniff” the network through the IEC61850/OUT port.

3.0 Current Sources

3.1 Parallel Operation

Each MPRT2145 current amplifier is capable of providing 30 Amperes continuous, and up to 45 amperes for 1.5 seconds for testing instantaneous trip elements. When more than 30 amps single phase is required for long durations, or 45 Amps for testing instantaneous elements, two or three current channels may be connected in parallel to provide 60 or 90 Amperes continuous, and up to 135 amperes for short durations (three units in parallel).

To parallel the current channels of multiple MPRT2145 units, perform the following:

If using the sleeved pair of current test leads (part number 2001-394), connect each current channel to the relay under test (both red and black terminals to the load). Each Megger test lead is rated for 32 Amperes continuous. If using test leads other than those supplied by Megger insure that the wire has sufficient size to carry the test current. See the following figure.

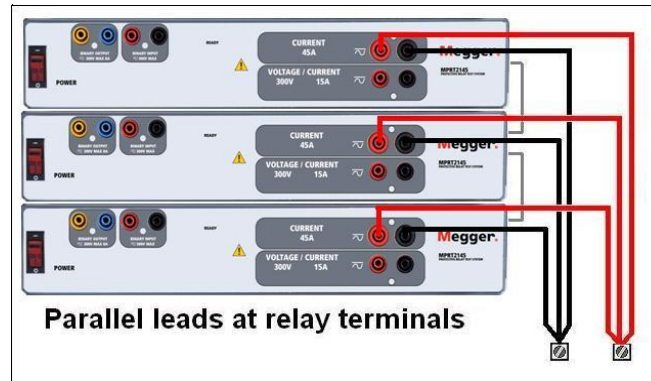

Figure 165 Parallel of Three MPRT2145 Current Outputs

3.1.1 Manual Test Screen - Single Phase Up To 135 Ampere

With three MPRT2145 interconnected, go to the Configuration screen and select the Operating Mode of **3 Voltages – 1 Current @ 135 amps**. When you return to the manual test screen there will be one current channel displayed, as shown in the following figure.

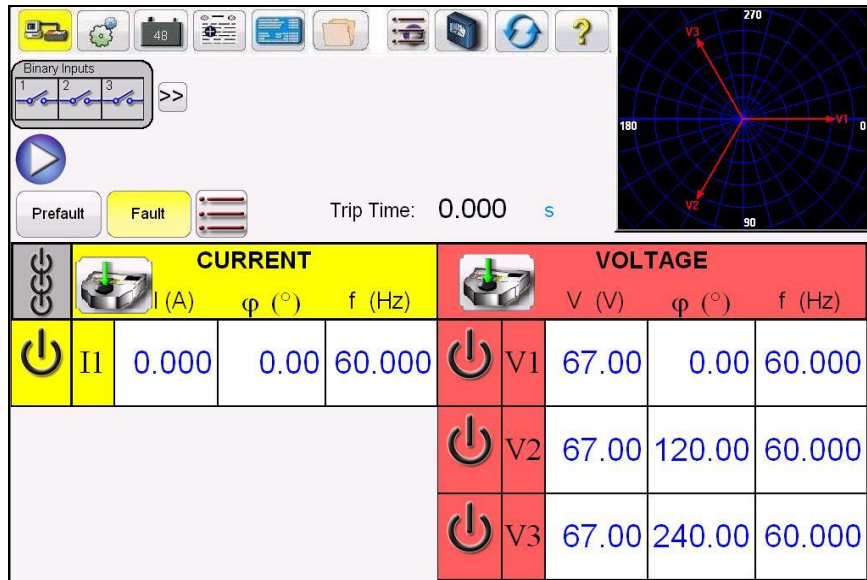

Figure 166 Manual Test Screen – 3 MPRT2145 Single Phase Current Operation

The STVI will automatically set all three currents in phase with each other and divide the current equally between the three current amplifiers. When setting an output, simply enter the value of the desired output current. For example, for an output of 75 Amperes, enter 75, while each current amplifier will be providing 25 Amperes. The current can also be phase shifted. Simply enter the desired phase angle and all three currents will be phase shifted together.

If two current channels that are to be used in parallel, connect the two current outputs to the load as shown in the following figure.

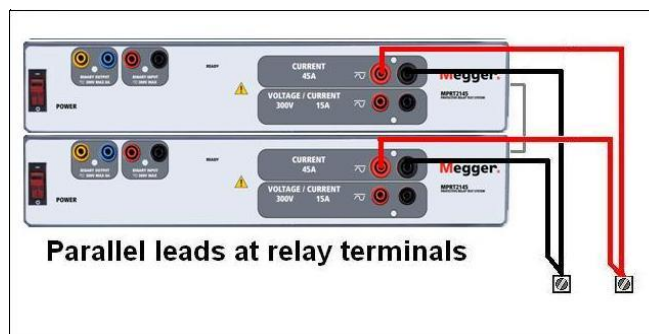



Figure 167 Two Currents in Parallel

Set each channel to one-half of the output requirement. Be sure and reset current channel #2 to 0 degrees so that it will be in-phase with current channel #1. With both current channels selected, turn output on by pressing or clicking on the ALL ON/OFF button. Always use the ALL ON/OFF button to turn both current channels on and off together. For manually ramping outputs, if using the PC version of the STVI software the \uparrow \downarrow buttons will be displayed. If using an STVI controller the Control Knob icon  will be displayed. Pressing either of these two will present the user with a window to select the desired level of increment for manually ramping the outputs, the desired channel(s) to be ramped, and what is to be adjusted (amplitude, phase angle or frequency).

3.2 Currents in Series Operation

Two current channels may be connected in series in order to double the available compliance voltage. High impedance electromechanical ground (earth) overcurrent relays have always been difficult to test at high multiples of tap due to the winding impedance and saturation characteristics. The peak voltage required can exceed the maximum output voltage of one MPRT2145 current output channel, depending on the required test current. By connecting two current outputs in series, the compliance voltage is doubled, providing higher test currents through the load. Connect the two current amplifiers in a “push-push” configuration as shown in the following figure.

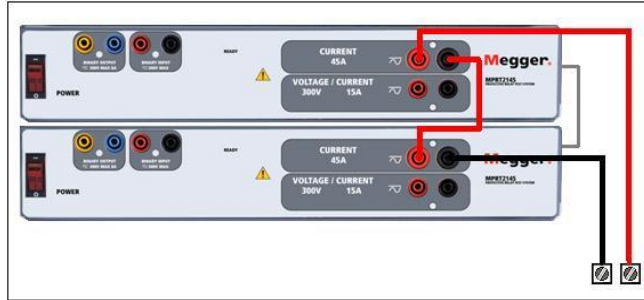



Figure 168 Series Two Currents

Using the STVI or the STVI software on a PC set each of two current channels to the same test current magnitude, and phase angle. Select both current channels and turn output on by pressing or clicking on the ALL ON/OFF button. Always use the ALL ON/OFF button to turn both current channels on and off together. For manually ramping outputs, if using the PC version of the STVI software the $\uparrow\downarrow$ buttons will be displayed. If using an STVI controller the Control Knob icon  will be displayed. Pressing either of these two will present the user with a window to select the desired level of increment for manually ramping the outputs, the desired channel(s) to be ramped, and what is to be adjusted (amplitude, phase angle or frequency).

4.0 Voltage Sources

4.1 Outputs Summed Together

Two voltage channels may be used to sum the voltage outputs to obtain higher than rated voltage provided the load is ungrounded. Connect the load between the voltage channel posts, set V_1 Phase to 0° and set V_2 Phase to 180° . The voltage outputs will add so the total voltage is the sum of the two voltage amplitudes, V_1 and V_2 as can be seen in the picture below.



Connect the associated voltage channels black common returns together, when series operation is required (see the following figure). DO NOT attempt to series more than two voltage channels together since the test leads are rated up to maximum of 600 Volts.

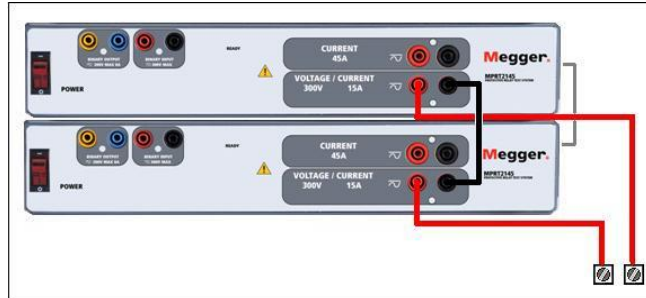

Figure 169 Series of Voltage Channels

4.2 3Ø, 3-Wire, Open-Delta and T-Connection

4.2.1 Balanced Open Delta

Two methods of obtaining a three-phase, three-wire voltage source are available. The Open-Delta configuration is the easier to use when a balanced three-phase source is required because the amplitude and phase relationship can be set directly. No calculations are necessary.

When using the Open-Delta configuration, it is suggested to use voltage channel #1, designated V_1 , and voltage channel #2, designated V_2 , while the COMMON binding post is designated V_g . With this arrangement, the magnitude and phase angle of the potentials can be easily calculated and set. For the balanced three-phase condition V_{1g} and V_{2g} are equal in magnitude and separated by an angle of 60° . This is done by setting the V_1 and V_2 potentials equal in magnitude, setting 0° on V_1 and 300° (60 degrees leading assuming that the default phase rotation is set to 360 Lag) on V_2 , see the following figures.

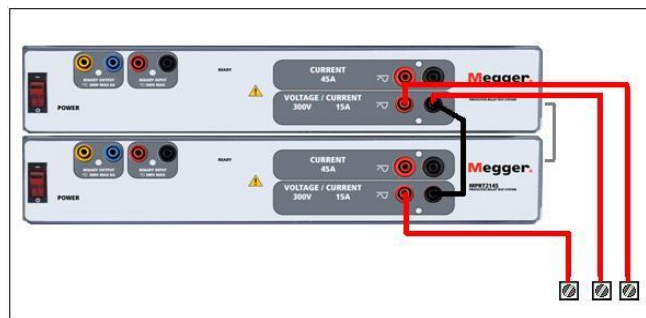
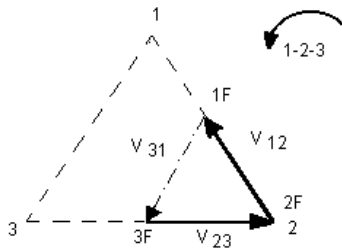

Figure 170 Three Phase Open Delta Connections

When using the Open-Delta Configuration to set up a phase-to-phase fault, calculations' using the Law of Cosines is required to calculate amplitude and phase relationships. (See discussion under T-Connection for simulating unbalanced, phase-to-phase faults without need for calculations.)



Balanced 30 - Open Delta Connection
 If V_f equals the desired test potential, then:
 Set $V_1 = V_f \angle 0^\circ$
 Set $V_2 = V_f \angle 300^\circ$ Lagging (60° Leading)

4.2.1.1 Unbalanced Open Delta

When setting up an Unbalanced Open-Delta configuration, the desired phase-to-phase fault voltage, V_{1f} is set using voltage channel #1 with its phase angle set to 0° . Phase-to-phase voltage V_{2f} and its phase angle relationship for voltage channel #2, must be calculated using the Law of Cosines; where For any triangle the following formula applies:

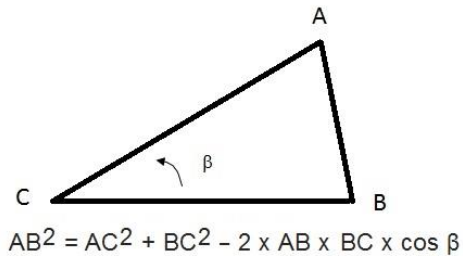

The next figure shows the phase relationships between voltages and an example of the necessary calculation. For convenience the amplitude and the phase angle settings for the typical V_f fault magnitudes are tabulated.

From the Law of Cosines

$$\theta = \arccos\left(\frac{V_{12}}{2 * V_{23}}\right)$$

$$V_{23}^2 = \left(\frac{V_{12}}{2}\right)^2 + \left(\frac{\sqrt{3}}{2} * 120\right)^2$$

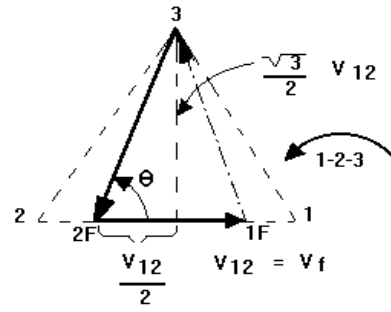

Figure 171 Open-Delta Unbalanced phase-to-phase Fault Voltages

Settings for Typical Phase-to-Phase Fault Voltages

$$V_{12} = V_{\text{fault}}$$

V₁₂	1	5	10	15	20	25	30	35	40	45	50	55	60	65	70
V₂₃	104	104	104	104	104	105	105	105	106	106	106	108	108	109	110
At θ° Lag	270	271	273	274	275	277	278	280	281	282	284	285	286	287	289

4.2.2 T Connection

The second method of obtaining a three-phase, three-wire voltage source is the so-called T-Connection. The method, shown in the following figure, is easier to use when obtaining an unbalanced, phase - to -phase fault simulation since it eliminates calculations. To reduce confusion when using the T-Connection, the voltage output #1 is designated V_a and its phase angle set at 0° , voltage output #2 is designated V_b and its phase angle set for 180° , and voltage output #3 is designated V_c and its phase angle is set for 270° . Any combination of balanced three phase faults or unbalanced phase-to-phase fault conditions can be easily simulated. The following figure indicates these phase relationships.

!NOTE: This method should not be used for very low fault voltages, or used on solid state relays that may be sensitive to this type of connection (i.e. 5 volts or less, or for testing ABB or Westinghouse type SKD relays).

$$V_f = \text{Desired Fault Voltage}$$

$$V_a = \frac{1}{2}V_f \angle 0^\circ$$

$$V_b = \frac{1}{2}V_f \angle 180^\circ$$

$$V_c = \frac{\sqrt{3}}{2} 120 \text{ or } V_c = 104V \angle 270^\circ$$

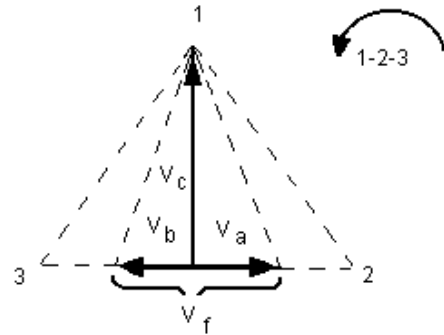

Balanced or Unbalanced Fault T-Connection

4.3 3Ø, 4-Wire, Y-Connection

A three-phase, four-wire potential system can be provided using three output modules. The vector relationships are referenced below. This Y-Connection has the advantage of being able to supply a higher line-to-line voltage ($1.73 \times$ phase-to-neutral voltage). It is ideally suited for simulating phase-to-ground faults. Voltage channel #1 is designated as V_a with its phase relationship set for 0° . Voltage channel #2 is then designated as V_b and phase angle set for 120° . Finally, voltage channel #3 is designated V_c and phase angle set for 240° (for a 1-2-3 counter clockwise rotation). V_a , V_b and V_c are connected to the voltage potential binding posts on the respective test sets.

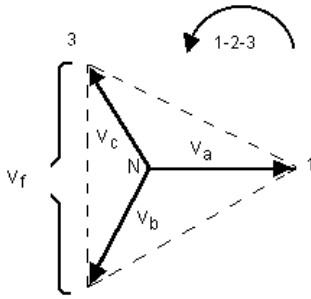

Balanced 3 ϕ , 4 Wire Y-Connection

$V_f = \text{Desired Fault Voltage}$

$$V_a = \frac{\sqrt{3}}{3} V_f \angle 0^\circ$$

$$V_b = \frac{\sqrt{3}}{3} V_f \angle 120^\circ$$

$$V_c = \frac{\sqrt{3}}{3} V_f \angle 240^\circ$$

If using the optional sleeved multi-lead voltage test leads (part number 2001-395), all of the black return leads are interconnected together inside the sleeve so they will all share the return together. Therefore, only one return lead is provided on the relay connection side of the sleeved leads (similar to the connections in the following figure).

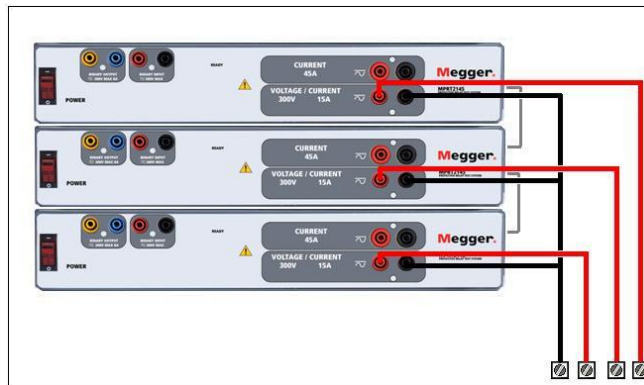

Figure 172 Three Phase Four Wire Voltage Test Connections

5.0 Warranty Statement

Megger warrants the product is free of defects in material and workmanship for a period of one (1) year from date of shipment. This warranty is non-transferable. This warranty is limited and shall not apply to equipment that has damage, or cause of defect, due to accident, negligence, and improper operation, faulty installation by the purchaser, or improper service or repair by any person, company or corporation not authorized by Megger. Megger will, at its' option, either repair or replace those parts and/or materials it deems to be defective.

The warranty is in lieu of all other warranties, either expressed or implied on the part of Megger and in no event shall Megger be liable for the consequential damages due to the breach thereof.

5.1 Preventive Maintenance

The unit utilizes surface mount technology (SMT) and other components which require little or no service except for routine cleaning, etc. The unit should be serviced in a clean atmosphere away from energized electrical circuits.

5.1.1 Examine the unit every six months for:

Dust and Dirt	To clean the unit, disconnect the power cord from the unit. Never use spray liquids or industrial cleaners. Some cleaning solvents can damage electrical components, and should never be used. Water and a mild soap may be used. Use a lightly damp cloth (not dripping wet) to wipe off the unit. A dirty heat sink can cause thermal overloads. Remove dust with dry, low pressure, compressed air. Either remove the enclosure or simply apply air forcing the dust away from the heat sink through the sides of the unit.
Moisture	Remove moisture as much as possible by putting the test set in a warm, dry environment.

5.1.2 Updating MPRT2145 Firmware

Download Firmware Upgrade via Megger Website

To download the newest firmware from the Megger website,

1. Go to WWW.Megger.com
2. **Log In.**
3. Go to **Software Downloads**
4. Click on **MPRT8445**
5. You will see instructions to enter the serial number of the MPRT2145 unit, and then click on **Continue**. The serial number is 12 digits long. Make sure you enter all 12 digits. Then click on **Firmware Version #.##**. **Note: the MPRT2145 uses the same firmware as the SMRT units, thus it will have a file name SMRT_Firmware_Version #.ldr**. The firmware will be downloaded onto your PC as a zip file. Unzip the file, **Select All** files, and **Copy** to a USB memory stick¹¹, or create a file on your PC for storage to unzip or extract to a file.

¹¹ You can use the STVI USB port to update the MPRT2145 firmware using a memory stick with the firmware on it.

USB Memory Stick: With the MPRT2145 and STVI powered up, insert the USB memory stick into the USB port on top of the STVI. Press the **Configuration** Screen button, and then press the **Update Firmware** button in the Configuration Screen. At that point the user will be presented with the IP Address selection screen, with the serial number of the unit. Select the unit by touching the serial number and the upgrade process will automatically start. That's all there is to it. Observe the STVI display screen, and the unit. At the completion of the download, the user will note the fans spin-up, and the LED's will be flashing rapidly on the MPRT2145 unit. There will be an instruction to reboot (turn off and back on) the test system.

PC and STVI Software: Upgrading using the PC version of the STVI software is very similar to the USB / STVI handheld controller method, see method described above. Upon clicking on the **Update SMRT (MPRT2145) Firmware** button, the familiar Windows Open File browser dialog box will appear. Using the **Look In** pull-down menu, navigate to where the new firmware was downloaded onto the PC, click on and open the file folder. There you will find the new firmware file **SMRT_Firmware_x.xx.ldr**. Click on the file, and click on Open. You will be requested to select a unit from the IP Address screen. Select the unit by clicking on the serial number and the upgrade process will automatically start. At the completion of the download, the user will note the fans spin-up, and the LED's will be flashing rapidly on the MPRT2145 unit. There will be an instruction to reboot (turn off and back on) the test system. Note that after rebooting the MPRT2145 unit, if using the PC version of the STVI software you will have to restart the STVI software on your PC in order to regain control of the MPRT2145 unit

5.2 Service and Repair Instructions

Basic troubleshooting information has been provided to guide the technician to the possible source of a problem.

Since MPRT2145 uses Surface Mount Technology, most repairs are beyond the scope of the basic troubleshooting guide, and should be referred to the Service Department at Megger or handled through the Megger Representative.

 If the unit is still within the original warranty period, or limited warranty period following factory servicing, **the factory must be contacted before attempting any repairs or the warranty will be void.**

5.2.1 Basic Troubleshooting

The troubleshooting information relies on the technician to have a good understanding of the operation of the unit. If the technician is unfamiliar with the unit, he or she should not attempt to repair. The technician should contact the factory before attempting repairs. Provide the Megger part number for the part or assembly in question and the serial number of the MPRT2145 when making inquiries.



WARNING It is necessary to energize the MPRT2145 to properly troubleshoot. The technician must take all applicable safety precautions for working near energized circuits.

NOTES

Before suspecting a failure in the MPRT2145, review the General Description and Operation sections to ensure that the problem is not a result of operating error.

Preliminary testing of the MPRT2145 within its specified limits can help determine if a malfunction actually exists, identify the type of malfunction and define the general area of the failure.

Common causes of malfunctions, other than improper operation, are incorrect power input (voltage above or below specified limits), incorrect test signal voltages applied to the Binary Input gate (outside of the specified AC/DC Applied/Removed limits), and contact or circuit resistance too great for the Dry Contact gates to operate properly on the Monitor/Start/Stop gate. Typical malfunctions for the VI-Gen amplifiers are external short circuits on the voltage output and open circuits on the current output. VI-Gen voltage and current outputs can be easily checked using a voltmeter and ammeter.



NOTE: Proper ESD procedures should be followed when handling any MPRT2145 VIGEN outside of the protective enclosure. Failure to do so, may damage sensitive parts.

5.2.1.1 Power Input

Input voltage affects the whole unit and may or may not cause permanent damage if voltage is incorrect. These problems can often be corrected by simply using a better source of input power. The rated voltage limit is auto-selectable from 100 to 240 volts, $\pm 10\%$, 47 to 63 Hz.

Some symptoms are as follows:

1. Low voltage: Erratic operation, no output, input power circuit breaker operation.
2. High voltage: Circuit breaker operation, power supply failure in Input Power Module.

5.2.1.2 VIGEN Input Power and Control

Basic troubleshooting of the input power is as follows.

No power: Check the ON/OFF circuit breaker. Does the ON/OFF switch light up? If it does not light up, then power is not getting to the unit. Check power source and line cord. If it lights up then the power is getting to the unit. Check the VIGEN internal power cable connections.



To check the internal connections requires the removal of the enclosure cover and the Warranty Sticker. If the unit is still in the warranty period, stop and contact your local Megger Sales office or representative. If in warranty, do not remove the sticker without written approval from Megger. Removing the warranty sticker without written approval may void the warranty.

Step 1 Disconnect the power cord from the unit, and remove top corner screws.

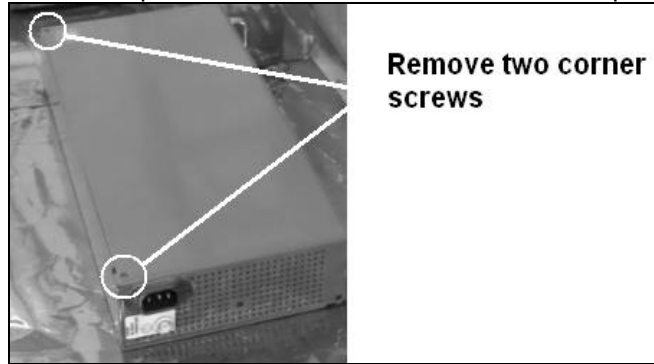

Step 2



Step 3

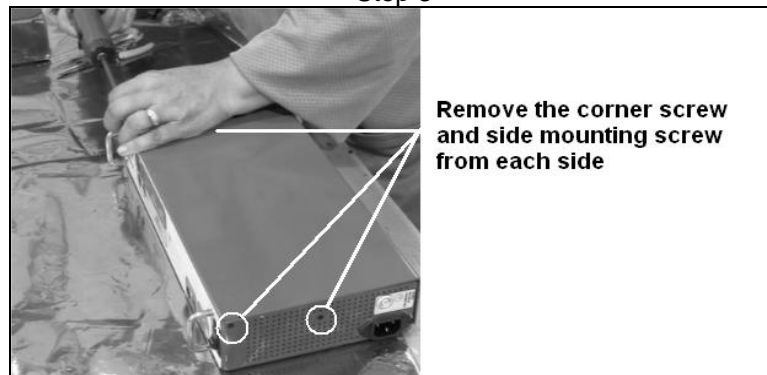

Step 4

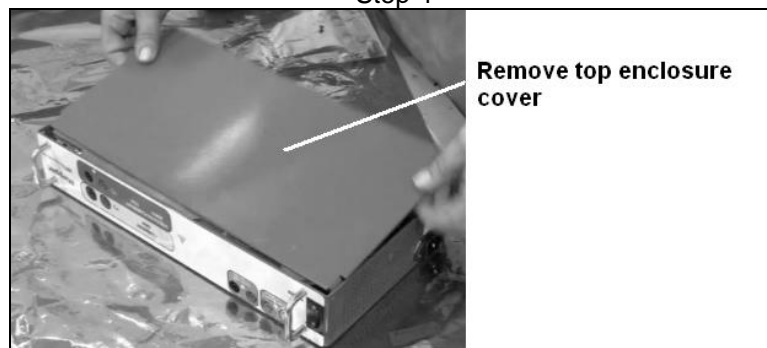



CAUTION: From this point on observe proper ESD procedures. Be careful when moving the VIGEN module as it is a tight fit, and it is possible to damage components upon extraction from or installation to the bottom half of the enclosure.

Step 5



Step 6

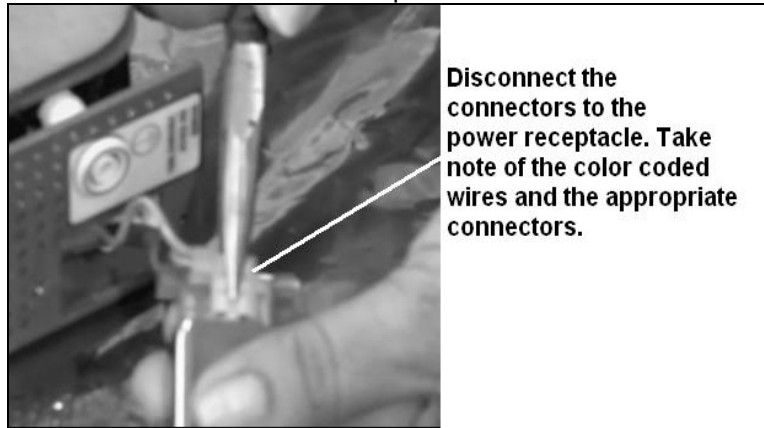

Step 7



Step 8

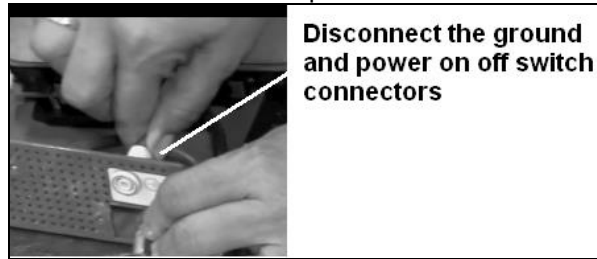

Step 9

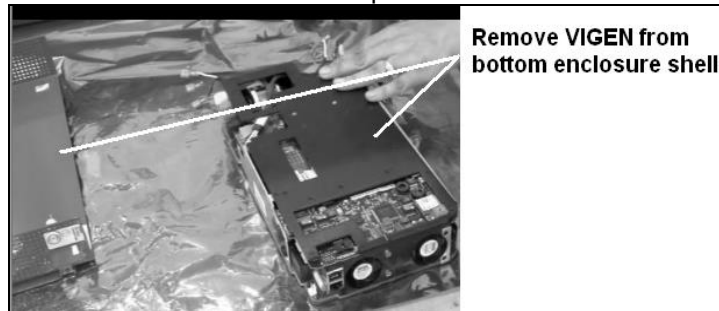

Step 10

Inspect the AC power connector

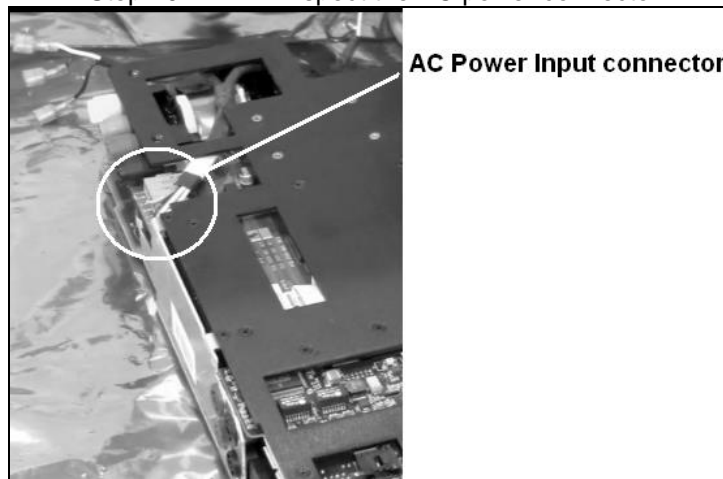

Look for possible discoloring of the wires and connector indicating overheating. Make a general observation of the VIGEN module looking for any obvious damage caused by a short circuit or other possible signs of trouble.

5.2.1.3 Binary Input and Binary Output

If all the items external of the unit are in proper order, then the problem exists within the Binary Input / Output assembly itself.

Some basic troubleshooting can pinpoint problems to the approximate cause.

Binary Input - Basic troubleshooting is as follows:

2. Timer does not stop:
Jumper the Binary Input terminals manually. If LED above the input lights, check the Binary Input setup screen to verify that the selected binary input is properly setup as a Timer stop post. Check Timer stop settings as N.O. (Normally Open) to close, and Latch On. If LED does not light up, the Binary Input will need to be repaired or replaced.

2. Counting errors:
AC applied or removed Stop signals can create, what appears to be poor repeatability, an inaccuracy or a malfunction in the Timer. The lower the voltage level, the more serious the "error" will be. What appears to be an error, however, is actually a variation in the point on the sine wave at which the voltage is great enough to cause the gate circuit to operate. If the circuit used for the timing test has a low AC voltage and the point at which the contact in the test circuit opens or closes, is at or close to zero on the sine wave, the period of time before the voltage level will be high enough to trigger the gate circuit can be as much as 4 milliseconds. The total timing variation can be as much as 8 milliseconds. The shorter the duration of the timing test, the more significant the variation becomes. Therefore, if small timing variations would present a problem, it is recommended that an AC voltage of 115 volts or above or a DC voltage be used for voltage applied/removed test selections.

When the MPRT2145 Timer calibration is being tested, the AC voltage variable is often overlooked. This is particularly true when the Timer is compared to a counter and the two are triggered simultaneously with an electronic switch. For best results, a DC voltage should be used to eliminate the variable. If testing the AC voltage Timer Stop characteristics is desired, then the Stop signal must be triggered at the same point on the sine wave to assure that the gate signal will be repeatable. Ideally, the signal should be at a point near peak in the positive direction. In addition, the specified rms AC voltage values for the various Stop control selections must be adhered to.

Another source of apparent "error" can be the programmable de-bounce feature. If using electro-mechanical contacts for stopping the Timer, and if those contacts have a tendency to bounce, there could be a difference between an external standard timer and the MPRT2145 Timer, depending on the programmed de-bounce period set in the MPRT2145 unit. To determine the programmed value, look at the Binary Input Setup Screen and see what the De-bounce setting value is.

If a timing error or variation persists after all the suspected causes of error have been eliminated, then it is possible that the Binary Input circuit is malfunctioning. Contact factory for return instructions.

Binary Output - Basic troubleshooting is as follows:

Binary Output LED is ON but output contacts **not closed**:

Using a continuity tester check to see if output circuit is open circuited. If circuit is open then it is possible that the internal surface mounted fuse element has been blown. Note: an optional in-line fused test lead Part Number: 568026 are available to provide

protection from switching too high current, see MPRT2145 Ordering Information under Optional Additional Accessories. The unit will need to be returned to the factory for further inspection and repair.

 Contact the factory for a Repair Authorization Number and return instructions if service is required. A Repair Authorization (RA) number will be assigned for proper handling of the unit when it arrives at the factory. Any non-warranty repair cost incurred for the repair or replacement of parts and/or materials shall be the responsibility of the purchaser.

Provide the factory with model number, Unit serial number, serial number of VI-Gen if appropriate, nature of the problem or service, return address, your name, and how to contact you should the factory need to discuss the service request.

You may need to provide a purchase order number, cost limit, billing, and return shipping instructions. If an estimate is requested, provide the name and contact information.

6.0 Preparation for Reshipment

 Save the original shipping container for future use. The shipping container is designed to withstand the rigors of shipping via a common commercial carrier. For example, you may wish to reship your unit to Megger for an annual calibration recertification.

Pack the equipment appropriately to prevent damage during shipment. If a reusable container is utilized, the unit will be returned in the same shipping container if it is in suitable condition.

Add the Return Authorization Number to the address label of the shipping container for proper identification and quicker handling.

 **NOTE:** Ship the equipment without nonessential items such as test leads, etc. These items are not needed by the factory to perform service.